



Progressa

SALICE

Index

Slide installation	page 7
Technical information	page 8
Part number composition	page 12



Front locking devices

Standard mount - 6 way adjustable	page 18
Vertical mount - 6 way adjustable	page 19
Standard mount - 2 way clip with side fixing	page 20
Narrow drawer clip	page 21
Drawer removal	page 22
Adjustments	page 24



**Progressa
Smove**

16 mm (5/8") drawer	Soft close for 13 mm (1/2") to 16 mm (5/8") drawer material thickness	page 30
19 mm (3/4") drawer	Soft close for 19 mm (3/4") drawer material thickness	page 32



**Progressa+
Smove**

16 mm (5/8") drawer	Soft close for 13 mm (1/2") to 16 mm (5/8") drawer material thickness	page 36
19 mm (3/4") drawer	Soft close for 19 mm (3/4") drawer material thickness	page 38



**Progressa+
Push to open**

16 mm (5/8") drawer	Push opening system for 13 mm (1/2") to 16 mm (5/8") drawer material thickness	page 42
19 mm (3/4") drawer	Push opening system for 19 mm (3/4") drawer material thickness	page 44



Progressa+ Shelf

Technical information

page 48



Progressa+ Shelf Smove

G7E6R

Concealed undermount Shelf runner - Full-extension

page 50



Progressa+ Shelf Push to open

G7E6Q

Concealed undermount Shelf runner - Full-extension

page 52



Accessories

Push synchronizer bar

page 56

Metal sockets

page 59

Plastic sockets

page 59

Drilling templates for drawers

page 60

Tilt adjustment lever

page 66

Side spacer

page 66

Spacer for 1/2" drawer sub-fronts

page 67

Rear-fixed bracket and magnet - Lock-open function for runners and drawers

page 68

Rear hook bracket

page 68

Screws and pozi driver

page 69

ø 6 mm drill bit for rear hook

page 70

Hex key to lock the stop collar set screw onto the 6mm drill bit

page 70

Drill bit stop collar for 6 mm bit

page 70

Progressa

Introducing **Progressa**, a cutting-edge generation of high-performance, full extension undermount drawer runners that redefine precision and durability.

Crafted using state-of-the-art technology, these slides feature our proprietary “S Drive” progressive module, ensuring an unparalleled level of functionality.

With static load capacities ranging from 120 lbs on **Progressa** to an impressive 170 lbs on **Progressa+**, and dynamic loads spanning from 100 to 154 lbs*, these slides deliver robust strength and reliability.

The rack and pinion action guarantees impeccable synchronization, silent movement, and optimal stability for a seamless user experience.

Innovative 6-way adjustable clips set **Progressa** apart, facilitating effortless side, depth, and height adjustments. Compatible with both standard and narrow drawer clips, **Progressa** offers versatility across a wide array of applications. Additionally, each slide provides an optional tilt adjustment for enhanced customization.

Progressa slides are available in Soft Close, Integrated Push-to-Open and Shelf versions, covering a length range from 9” to 30”. Compatible with 1/2” to 5/8” and 3/4” drawer sides.

Elevate your drawer experience with **Progressa**, where precision meets innovation.

Smove



Soft close feature fully integrated in the runner system.



* Per Ansi BHMA A156.9-2020 Grade 1 standard in a frameless cabinet using a 21” runner length and a recommended number of fixing screws.



Push-to-Open feature fully integrated in the runner system



Synchronizer for Progressa+ Push slides (Optional)

The synchronization system for Push-to-Open **Progressa+** slides has been developed to ensure that wider drawers can be opened with minimum effort. Applying pressure on any part of the drawer front (even at the extremities), is sufficient for the Push devices to release and consequently for the drawer to open.

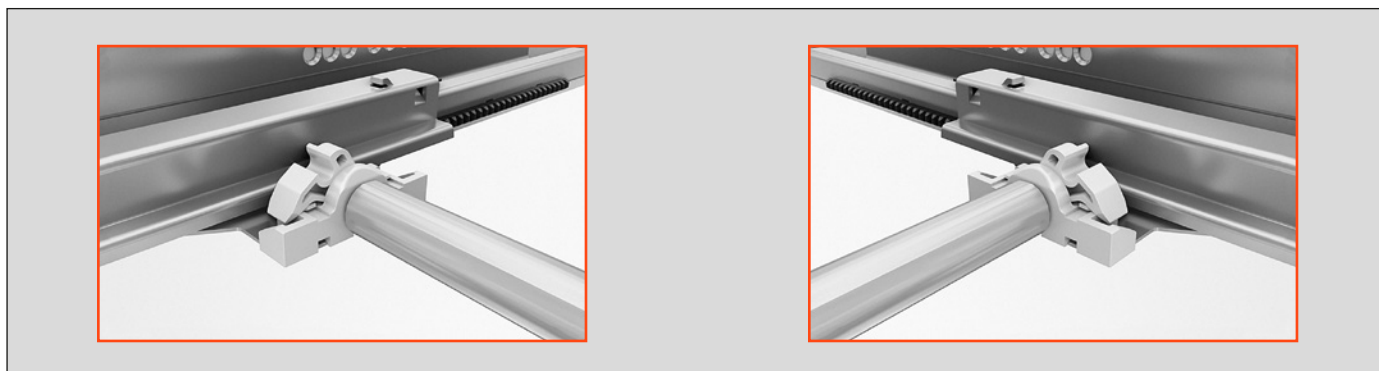

Progressa

Front locking devices

A full range of fixing clip options, ranging from stamped steel 6-way adjustable clips with intuitive side, depth and height adjustments, narrow drawer clips and 2-way adjustable locking devices for more competitive markets.



Salice S-Drive system

All versions and lengths of Progressa have an integrated rack and pinion system, which synchronizes the sliding elements and guarantees a true progressive action, excellent lateral stability, with any drawer size, and a perfectly silent movement without the need for further components.



Slide installation

For all Progressa and Progressa+ slides

Mounting full-extension runner on cabinet side

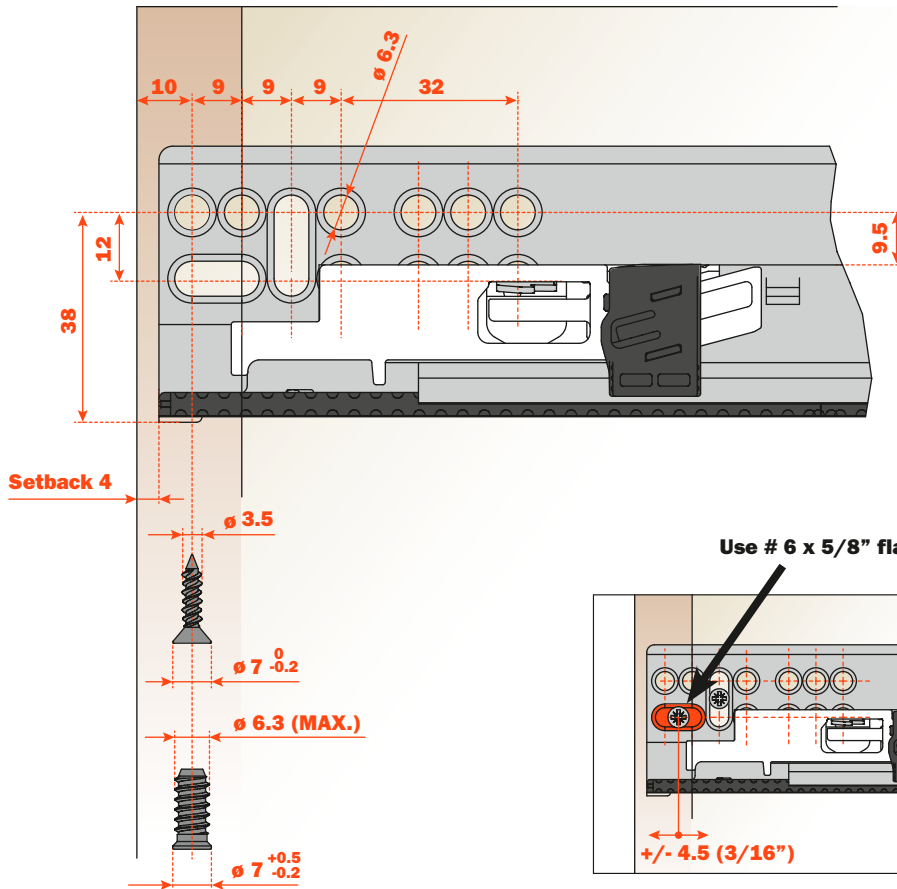

See **screws**, page 69.

Use # 6 x 5/8" flat head (see page 69)

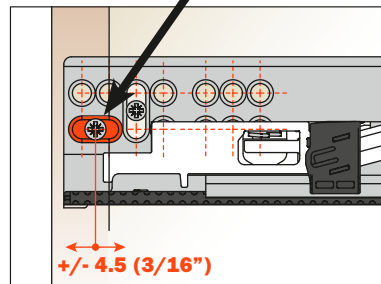

Elongated holes are for $\pm 4.5 (3/16'')$ **depth adjustment** only. Additional screws must be used to secure the runner to the cabinet.

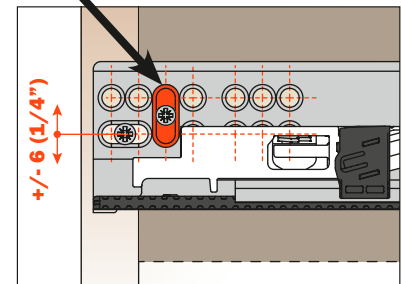

Elongated holes are for $\pm 6 (1/4'')$ **vertical adjustment** only. Additional screws must be used to secure the runner to the cabinet. Only with frameless application or face frame application with filler.

Drawer slide assembly Face frame application without filler behind frame

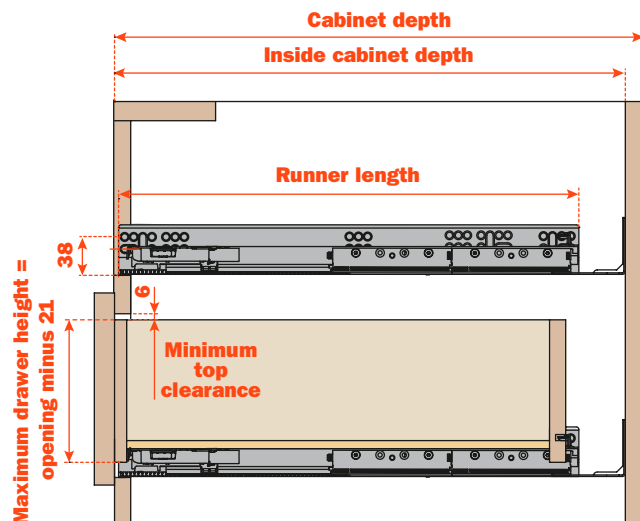

Drawer slide assembly Face frame application with filler behind frame Frameless application

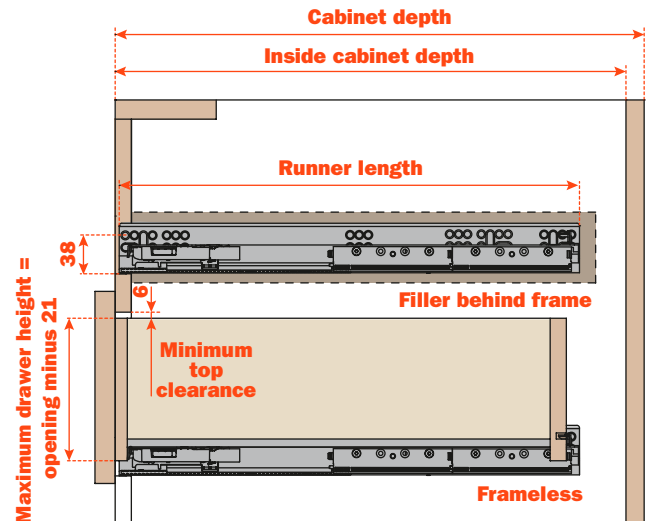

Drilling patterns - Standard face frame cabinet member

For all Progressa and Progressa+ slides

Please refer to the specific product pages in this catalog for all technical data

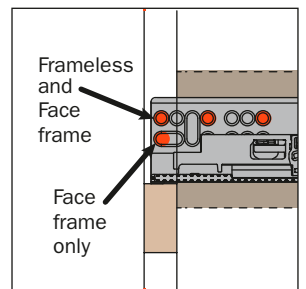
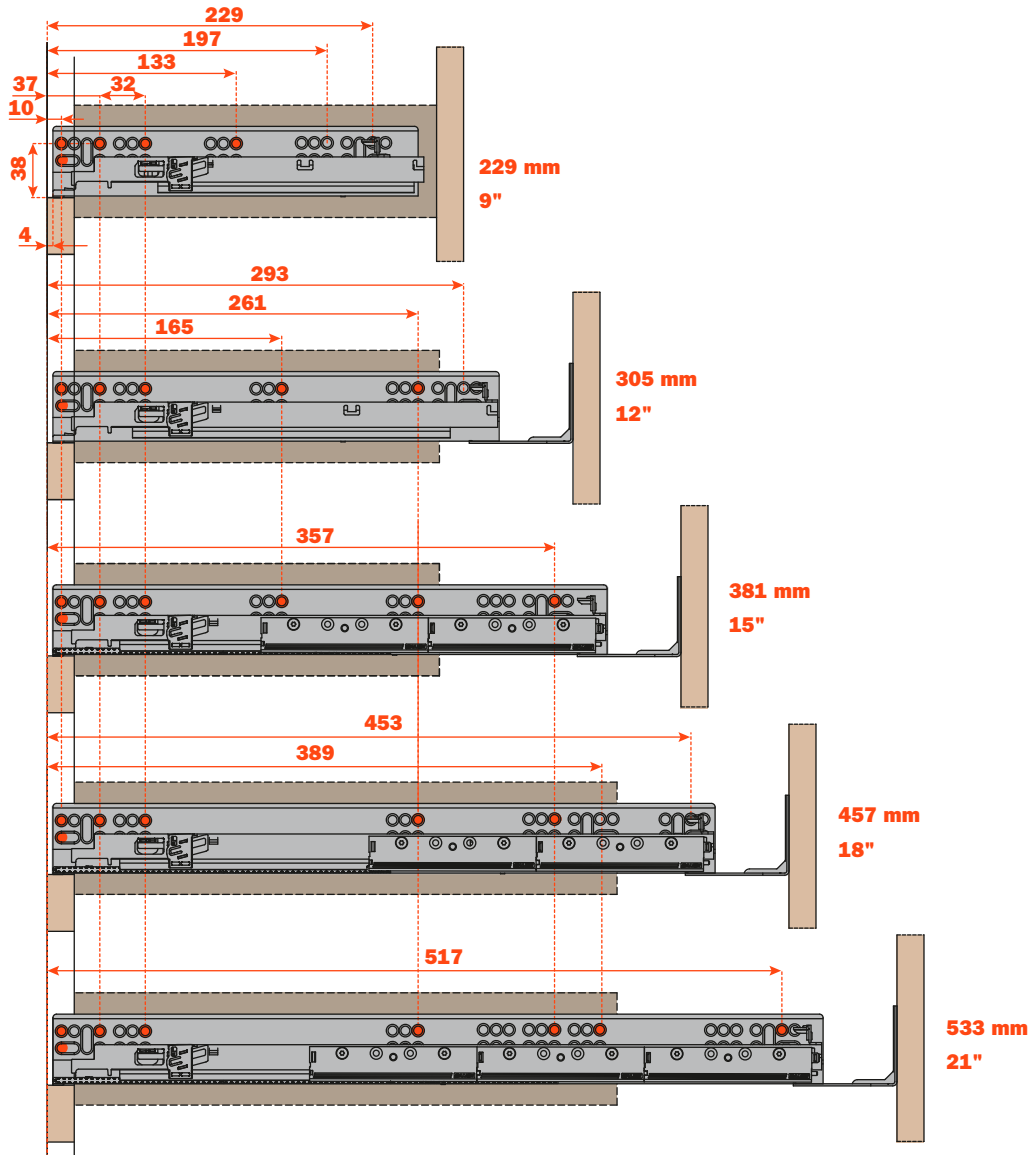

Note: orange dots indicate fixing screw locations and quantity recommended to meet load ratings.

Mounting to the cabinet side - Runner lengths 229, 305, 381, 457 and 533 mm

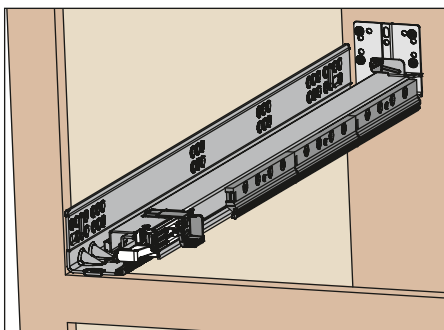

Face frame application without filler behind frame

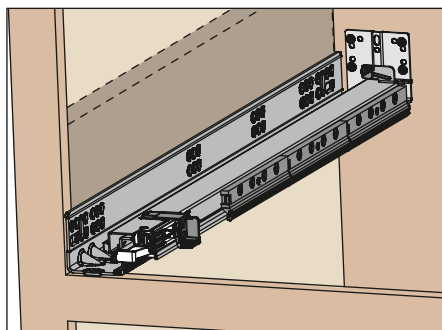

Face frame application with filler behind frame

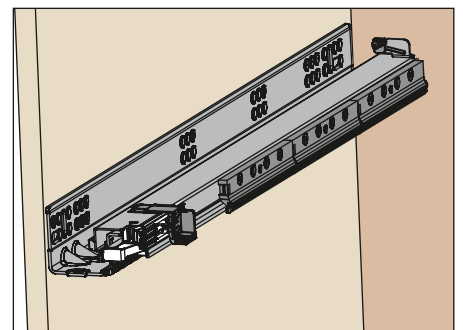

Frameless application

Use of rear sockets for any load above 75 Lbs is not recommended

Sockets and brackets can be used for the correct alignment of the runners before fixing to the cabinet side.

Drilling patterns - Short version cabinet member

For all Progressa+ slides

Please refer to the specific product pages in this catalog for all technical data

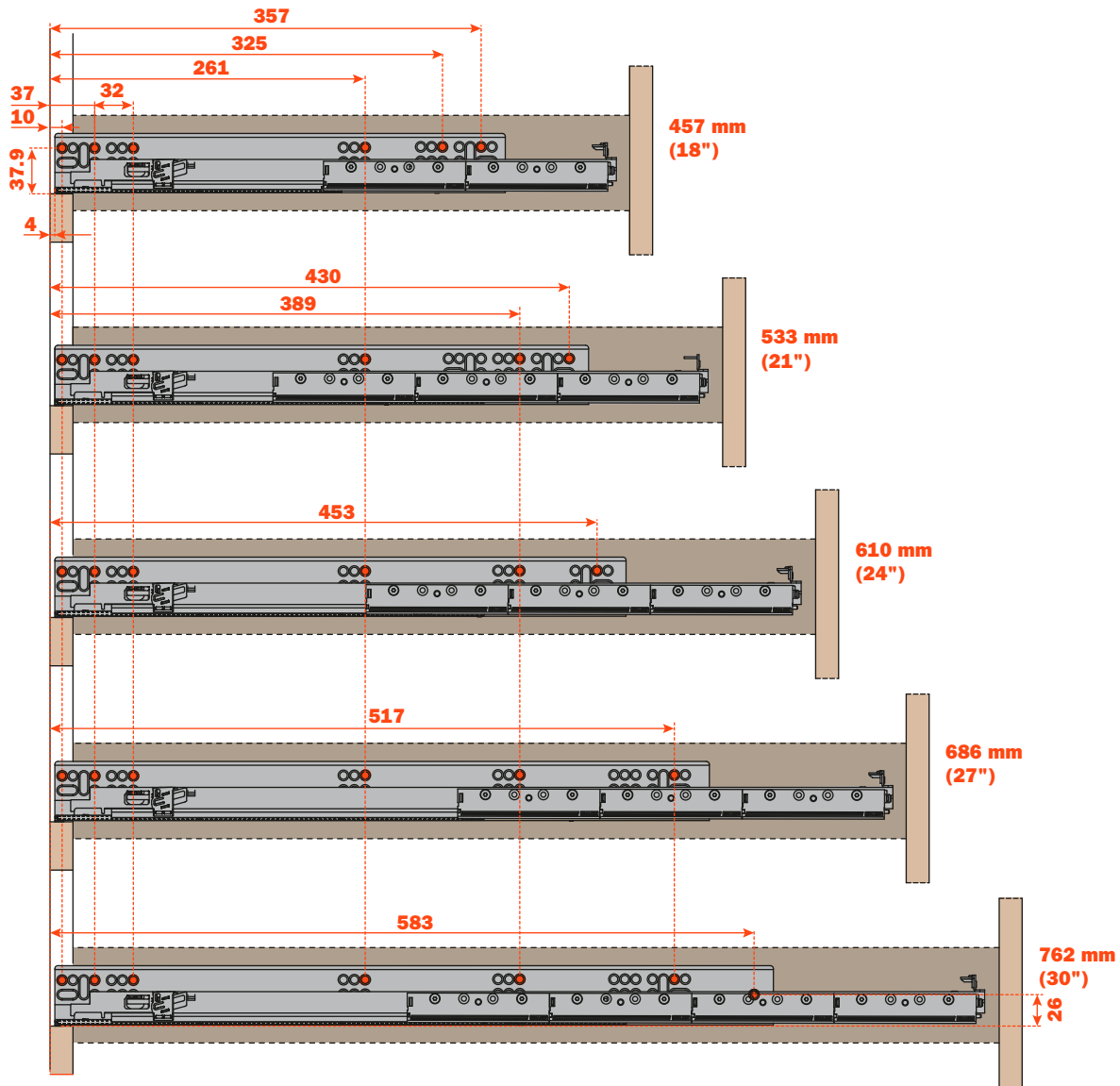

Note: orange dots indicate fixing screw locations and quantity recommended to meet load ratings.

Mounting to the cabinet side - Runner lengths 457, 533, 610, 686 and 762 mm

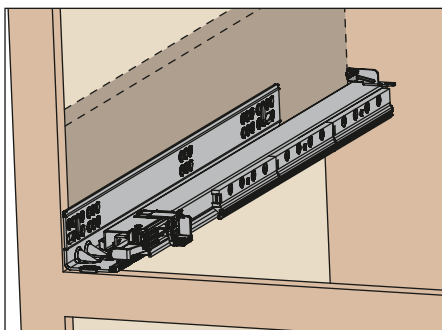

Face frame application with filler behind frame

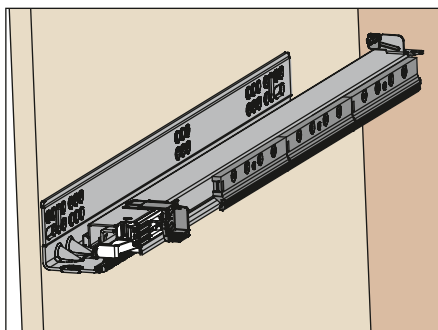

Frameless application

Use of at least 4 fixing screws to the side is highly recommended. For these runner lengths rear brackets and sockets cannot be used. Cabinet sides must be blocked. On longer lengths load capacity may vary.

Drawer settings

For all Progressa and Progressa+ slides

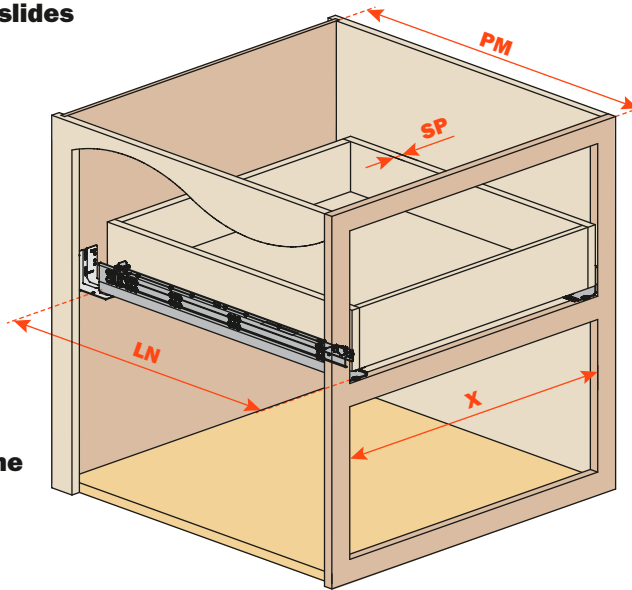

**Face frame application
without filler behind frame**

**DRAWER SETTING
ABBREVIATIONS:**

- SP** = Drawer thickness
- LN** = Nominal runner length
- PM** = Cabinet depth
- X** = Cabinet internal width
- LC** = Drawer length

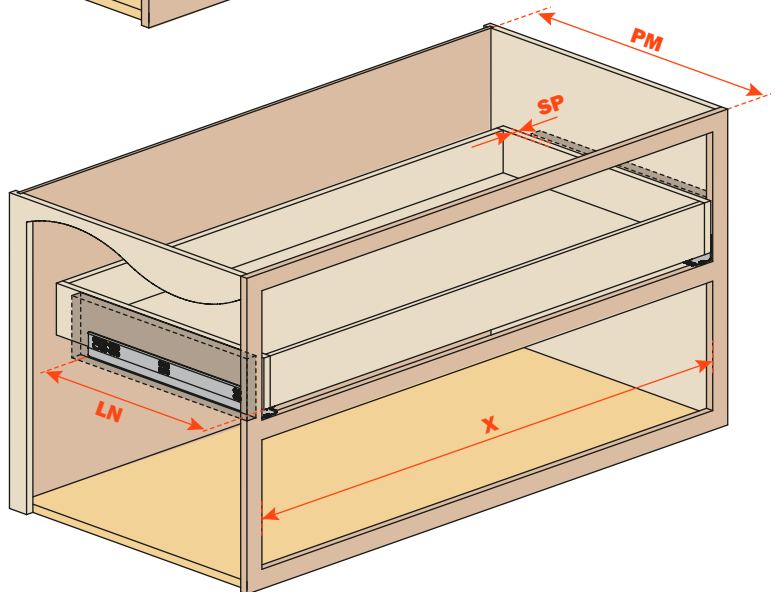

**Face frame application
with filler behind frame**

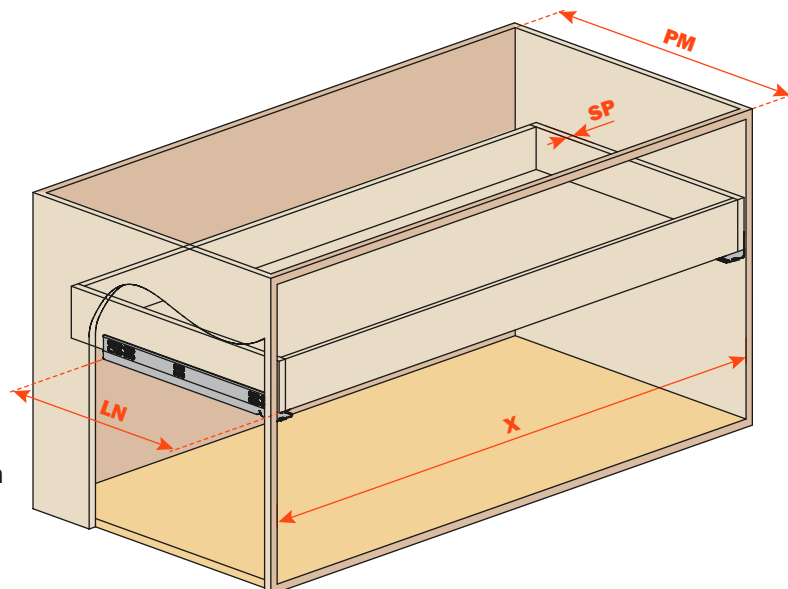

Frameless application

Drawer dimensions and drilling

For all Progressa and Progressa+ slides

Full-extension runner for 13 mm (1/2") to 16 mm (5/8") drawer material thickness

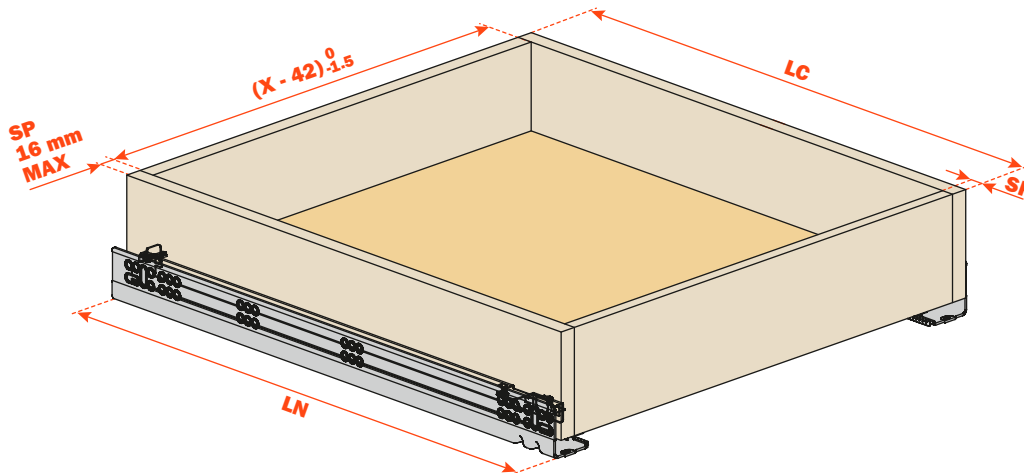

For drawer sides with sub-fronts between 12 and 13 mm (1/2"), we recommend the use of the build-up spacer **AFSFXXB**.

See page 67 for specs.

SP = Drawer thickness

Full-extension runner for 19 mm (3/4") drawer material thickness

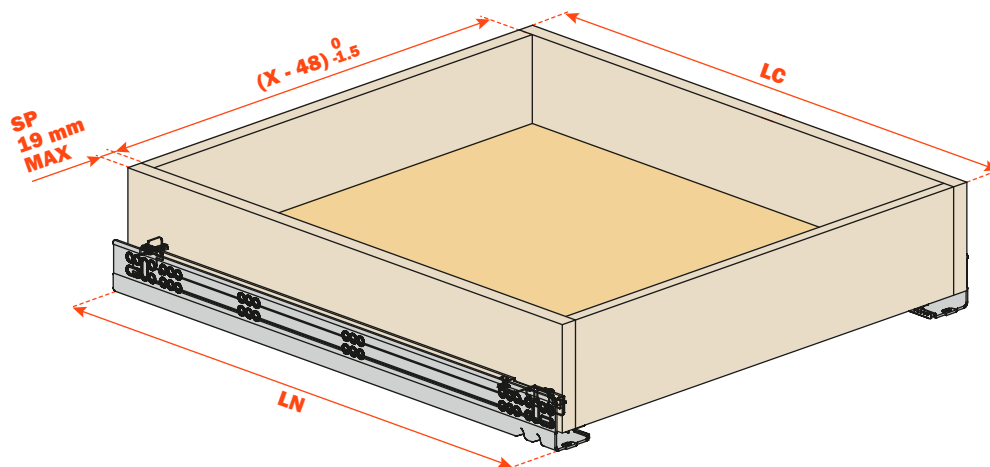

Rear hook



Use **drilling templates** for rear hook, see pages 60 and 63.

Drawer back preparation

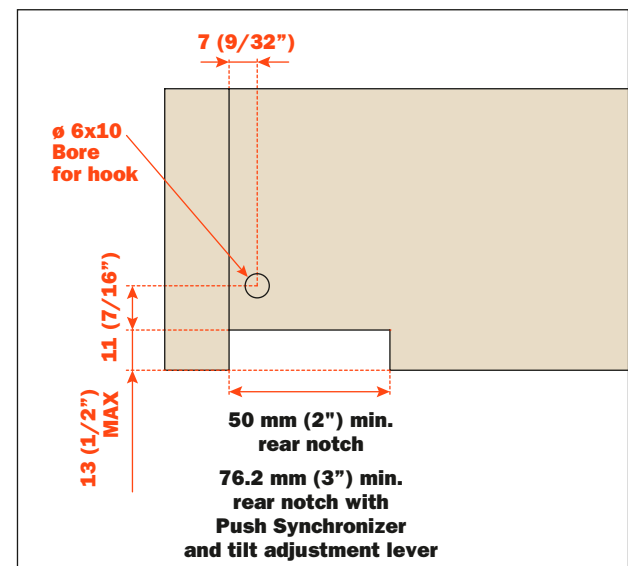

Progressa+ Push Synchronizer, see page 56.
AGLRXX3F tilt adjustment lever, see page 66.

Part number composition - For Progressa and Progressa+ Slides

Example:

G U - - - - XF

5 = Progressa
7 = Progressa+

DRAWER THICKNESS

6 = for 13 mm (1/2") to 16 mm (5/8")
drawer material thickness

9 = for 16 mm (5/8") to 19 mm (3/4")
drawer material thickness

ARTICLE VERSIONS

S = Soft close
P = Push to open

DRAWER LENGTH

229, 305, 381, 457, 533, 610, 686, 762 mm

ARTICLE VERSIONS

6 = 6 prs for 229, 305, 381, 457, and 533
runner length

2 = 2 prs for 610, 686 and 762 runner length

X = STANDARD FACE FRAME CABINET MEMBER

- face frame application without filler behind frame
- face frame application with filler behind frame
- frameless application
- for 305, 381, 457, and 533 runner length

C = SHORT CABINET MEMBER

- face frame application with filler behind frame
- frameless application
- for 229, 457, 533, 610, 686 and 762 runner length

Packaging

Progressa Smove

16 mm (5/8") drawer Soft close for 13 mm (1/2") to 16 mm (5/8") material thickness

SMOVE	LENGTH	BOX	PALLET
G5U6S229XF6	229 mm	6 prs	192 prs
G5U6S305XF6	305 mm	6 prs	192 prs
G5U6S381XF6	381 mm	6 prs	192 prs
G5U6S457XF6	457 mm	6 prs	192 prs
G5U6S457CXF6	457 mm	6 prs	192 prs
G5U6S533XF6	533 mm	6 prs	192 prs
G5U6S533CXF6	533 mm	6 prs	192 prs

19 mm (3/4") drawer Soft close for 19 mm (3/4") material thickness

SMOVE	LENGTH	BOX	PALLET
G5U9S381XF6	381 mm	6 prs	192 prs
G5U9S457XF6	457 mm	6 prs	192 prs
G5U9S457CXF6	457 mm	6 prs	192 prs
G5U9S533XF6	533 mm	6 prs	192 prs
G5U9S533CXF6	533 mm	6 prs	192 prs

Progressa+ Smove

16 mm (5/8") drawer Soft close for 13 mm (1/2") to 16 mm (5/8") material thickness

SMOVE	LENGTH	BOX	PALLET
G7U6S381XXF6	381 mm	6 prs	192 prs
G7U6S457XXF6	457 mm	6 prs	192 prs
G7U6S457CXF6	457 mm	6 prs	192 prs
G7U6S533XXF6	533 mm	6 prs	192 prs
G7U6S533CXF6	533 mm	6 prs	192 prs
G7U6S610CXF2	610 mm	2 prs	128 prs
G7U6S686CXF2	686 mm	2 prs	128 prs
G7U6S762CXF2	762 mm	2 prs	128 prs

19 mm (3/4") drawer Soft close for 19 mm (3/4") material thickness

SMOVE	LENGTH	BOX	PALLET
G7U9S381XXF6	381 mm	6 prs	192 prs
G7U9S457XXF6	457 mm	6 prs	192 prs
G7U9S457CXF6	457 mm	6 prs	192 prs
G7U9S533XXF6	533 mm	6 prs	192 prs
G7U9S533CXF6	533 mm	6 prs	192 prs
G7U9S610CXF2	610 mm	2 prs	128 prs
G7U9S686CXF2	686 mm	2 prs	128 prs
G7U9S762CXF2	762 mm	2 prs	128 prs

Progressa+ Push to open

16 mm (5/8") drawer Push opening system for 13 mm (1/2") to 16 mm (5/8") material thickness

PUSH	LENGTH	BOX	PALLET
G7U6P381XXF6	381 mm	6 prs	192 prs
G7U6P457XXF6	457 mm	6 prs	192 prs
G7U6P457CXF6	457 mm	6 prs	192 prs
G7U6P533XXF6	533 mm	6 prs	192 prs
G7U6P533CXF6	533 mm	6 prs	192 prs
G7U6P610CXF2	610 mm	2 prs	128 prs
G7U6P686CXF2	686 mm	2 prs	128 prs
G7U6P762CXF2	762 mm	2 prs	128 prs

19 mm (3/4") drawer Push opening system for 19 mm (3/4") material thickness

PUSH	LENGTH	BOX	PALLET
G7U9P381XXF6	381 mm	6 prs	192 prs
G7U9P457XXF6	457 mm	6 prs	192 prs
G7U9P457CXF6	457 mm	6 prs	192 prs
G7U9P533XXF6	533 mm	6 prs	192 prs
G7U9P533CXF6	533 mm	6 prs	192 prs
G7U9P610CXF2	610 mm	2 prs	128 prs
G7U9P686CXF2	686 mm	2 prs	128 prs
G7U9P762CXF2	762 mm	2 prs	128 prs

Part number composition - For Progressa+ Shelf Slides

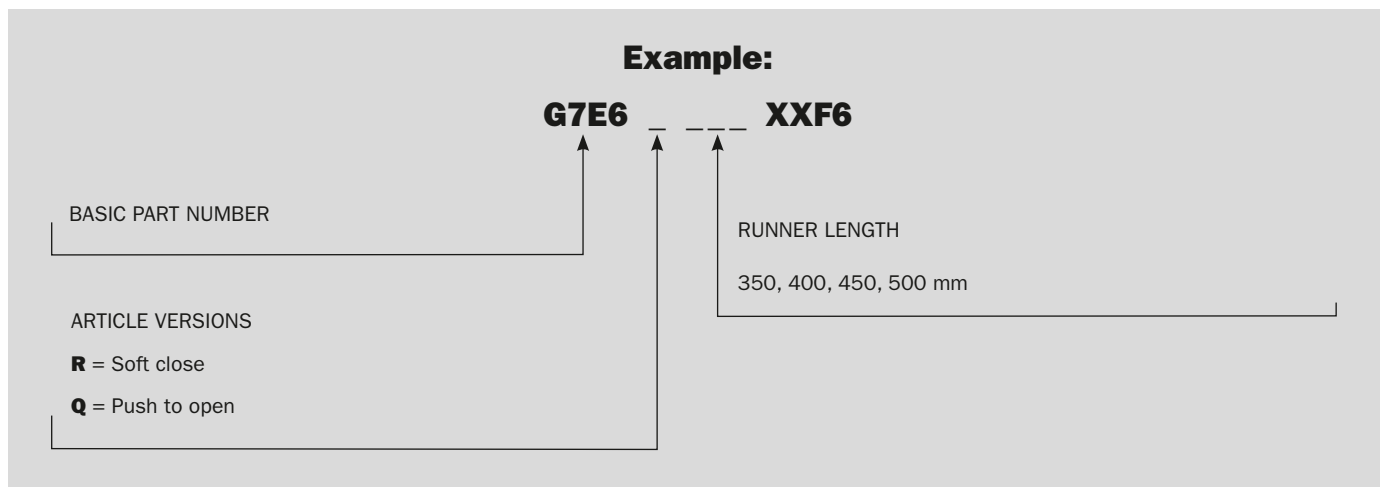

Packaging

**Progressa+
Shelf Smove**

SMOVE	LENGTH	BOX	PALLET
G7E6R350XXF6	350 mm	6 prs	192 prs
G7E6R400XXF6	400 mm	6 prs	192 prs
G7E6R450XXF6	450 mm	6 prs	192 prs
G7E6R500XXF6	500 mm	6 prs	192 prs

**Progressa+
Shelf Push to open**

PUSH	LENGTH	BOX	PALLET
G7E6Q350XXF6	350 mm	6 prs	192 prs
G7E6Q400XXF6	400 mm	6 prs	192 prs
G7E6Q450XXF6	450 mm	6 prs	192 prs
G7E6Q500XXF6	500 mm	6 prs	192 prs

Components

FRONT LOCKING DEVICES	BOX	PALLET
AFCGXX3B	100 pcs right / 100 pcs left	2400 pcs right / 2400 pcs left
AFCGX43B	100 pcs right / 100 pcs left	2400 pcs right / 2400 pcs left
AFCEX56B	100 pcs right / 100 pcs left	2400 pcs right / 2400 pcs left
AFCGX43B	100 pcs right / 100 pcs left	2400 pcs right / 2400 pcs left

SOCKETS	BOX	PALLET
AGSK7C5B	100 pcs	4000 pcs
AGSK7R5B	100 pcs	4000 pcs
ASOG5G7AJYD	100 pcs	4000 pcs
ASOG5G7AJND	100 pcs	4000 pcs

TILT ADJUSTMENT LEVER	BOX	PALLET
AGLRXX3F	12 pcs right / 12 pcs left	2400 pcs right / 2400 pcs left

SPACERS	BOX	PALLET
ASPACERFUT	100 pcs	-
AFSFXXB	100 pcs	-

REAR-FIXED BRACKET AND MAGNET (SHELF)	BOX	PALLET
AROSXXY	20 magnets, 20 brackets	-

REAR HOOK BRACKET (SHELF)	BOX	PALLET
AGAPXXYI	100 pcs	-



Front locking devices

Front locking devices - Standard mount - Side and depth adjustments

For all Progressa, Progressa+ and Progressa+ Shelf slides

- Dual steel/fiber glass-nylon construction
- Compatible with all Progressa slides
- Tool free lateral and depth adjustments
- Pre-drilling recommended \varnothing 2.5 mm (3/32")

AFCGX3B

PACKAGING: 2 boxes = 100 pcs right and 100 pcs left

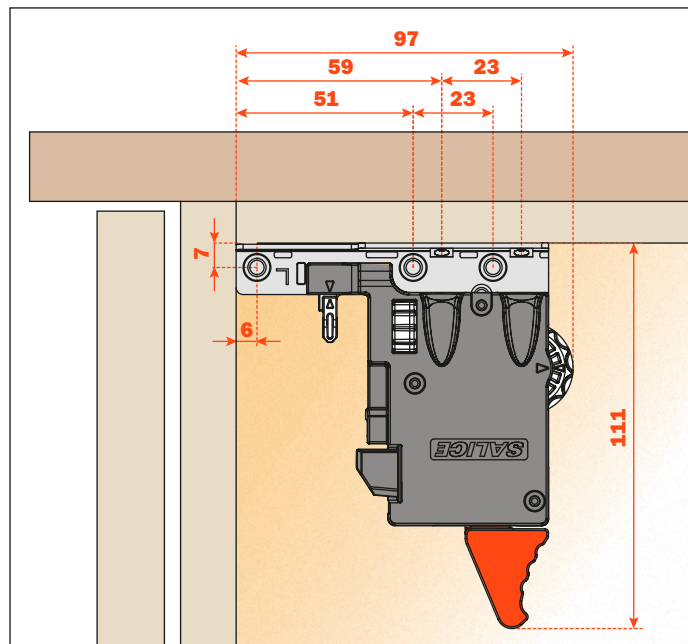

Assembly to the bottom

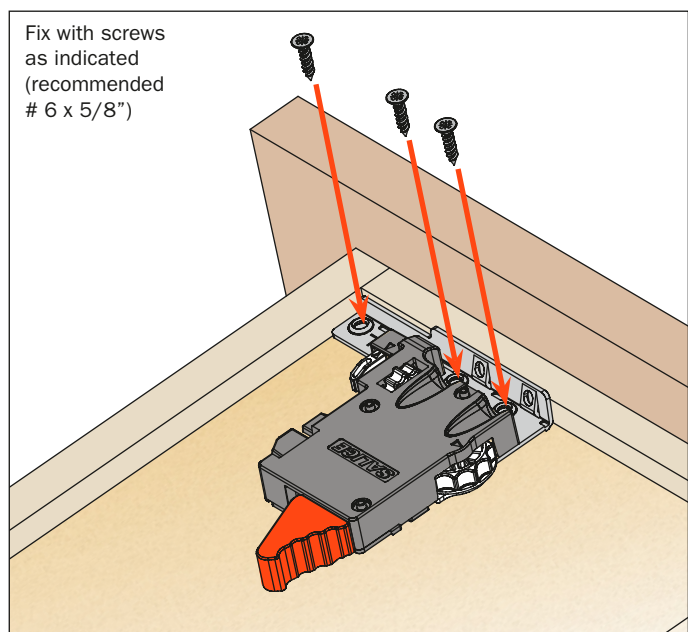

Assembly to the drawer

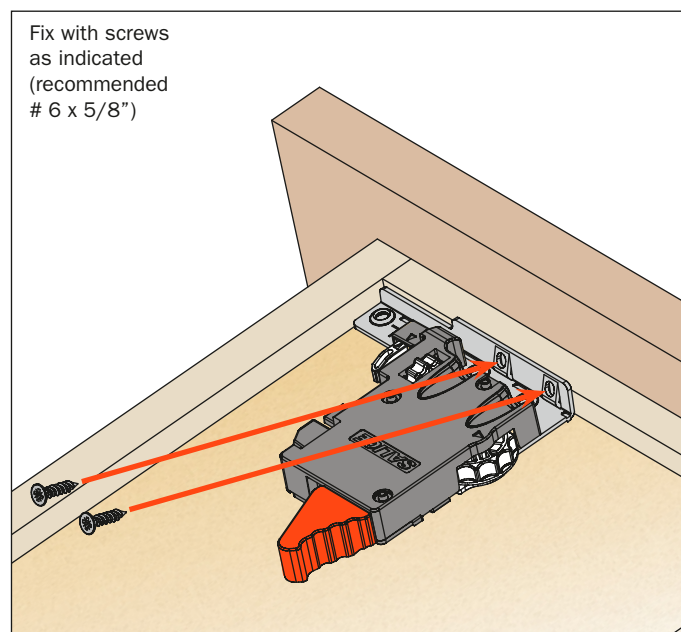

Use **drilling templates** for accurate installation of the clips, see page 60.

Front locking devices - Vertical mount - Side and depth adjustments

For all Progressa and Progressa+ slides

- Dual steel/fiber glass-nylon construction
- Compatible with all Progressa slides
- Tool free lateral and depth adjustments
- Height of the sub front must be 13 mm (1/2")
- Pre-drilling recommended \varnothing 2.5 mm (3/32")

AFCGX43B

PACKAGING: 2 boxes = 100 pcs right and 100 pcs left

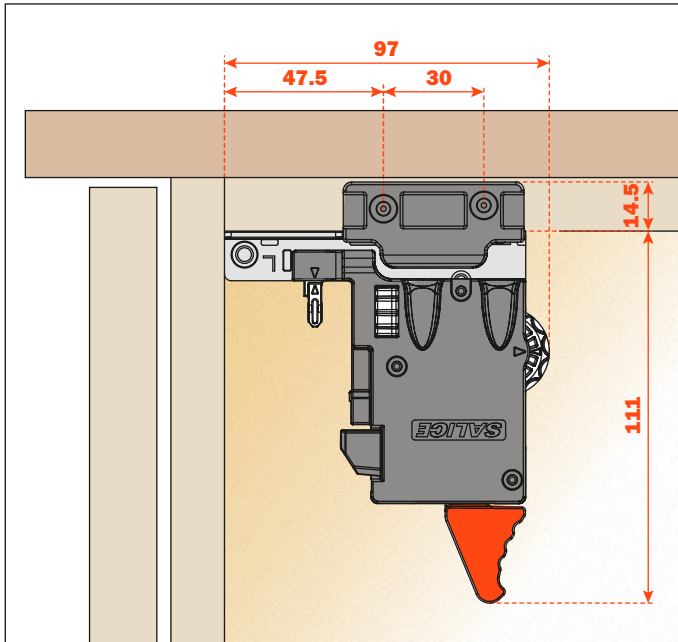

Assembly to the drawer top side

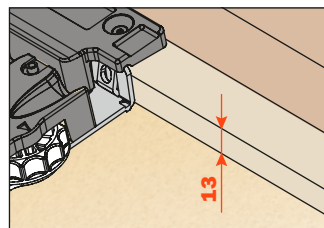
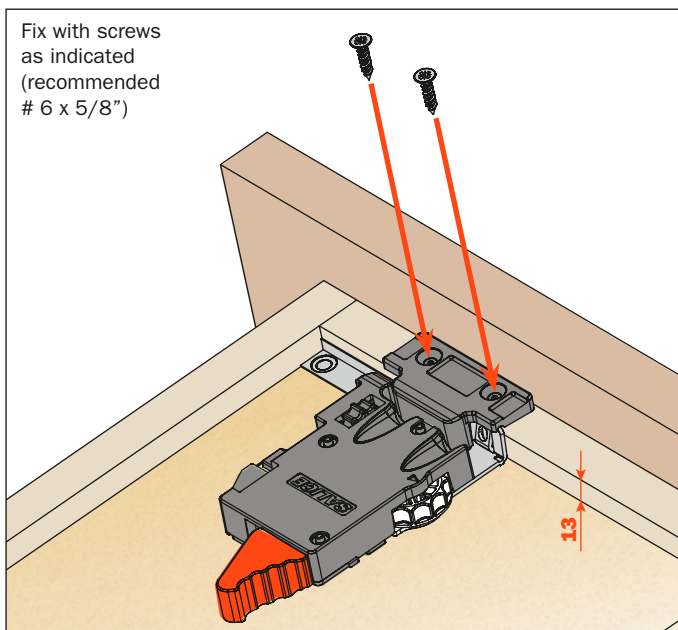

Use **drilling templates** for accurate installation of the clips, see page 60.

Height of the sub front must be 13 mm (1/2").

Front locking devices - Standard mount - Front and side fixing

For all Progressa, Progressa+ and Progressa+ Shelf slides

- Engineered thermoplastics
- Compatible with all Progressa slides
- Side fixing option
- Pre-drilling recommended \varnothing 2.5 mm (3/32")
- Minimum inside drawer width 5-1/8"
- Minimum inside cabinet width 6-3/4"

AFCEX56B

PACKAGING: 2 boxes = 100 pcs right and 100 pcs left

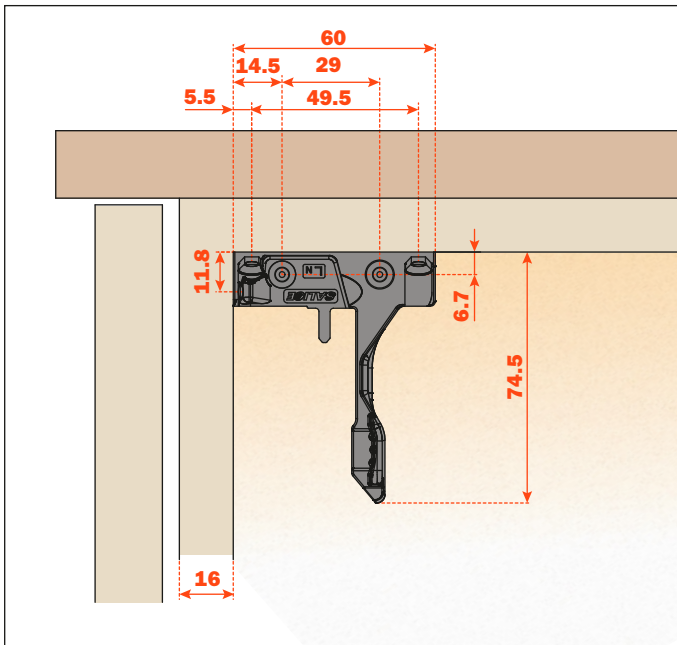

Assembly to the bottom

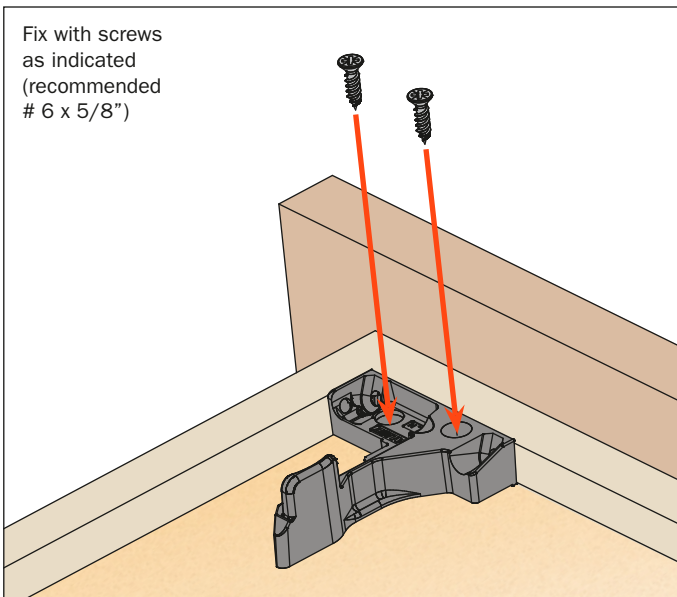

Assembly to the drawer

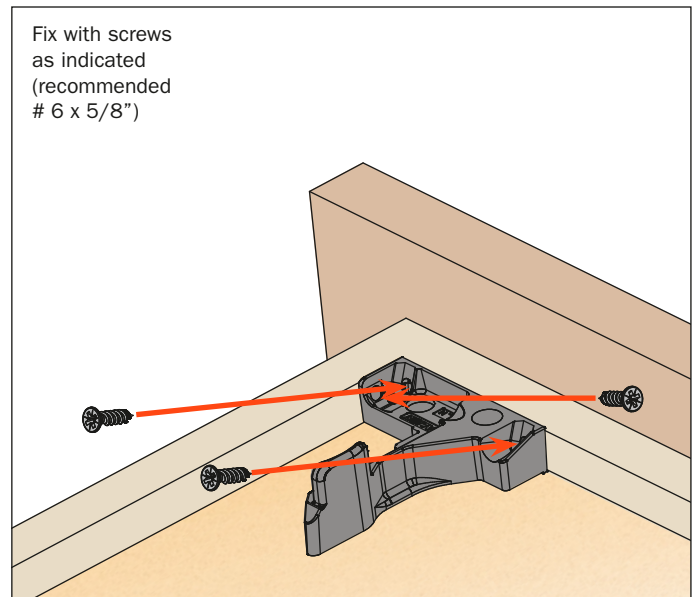

Use **drilling template** for accurate installation of the clips, see page 63.

Front locking devices - Narrow drawer clip

For all Progressa and Progressa+ slides

- Engineered thermoplastics
- For use with narrow drawers
- Compatible with all Progressa slides
- Height of the sub front must be 13 mm (1/2")

AFCEX43B

PACKAGING: 2 boxes = 100 pcs right and 100 pcs left

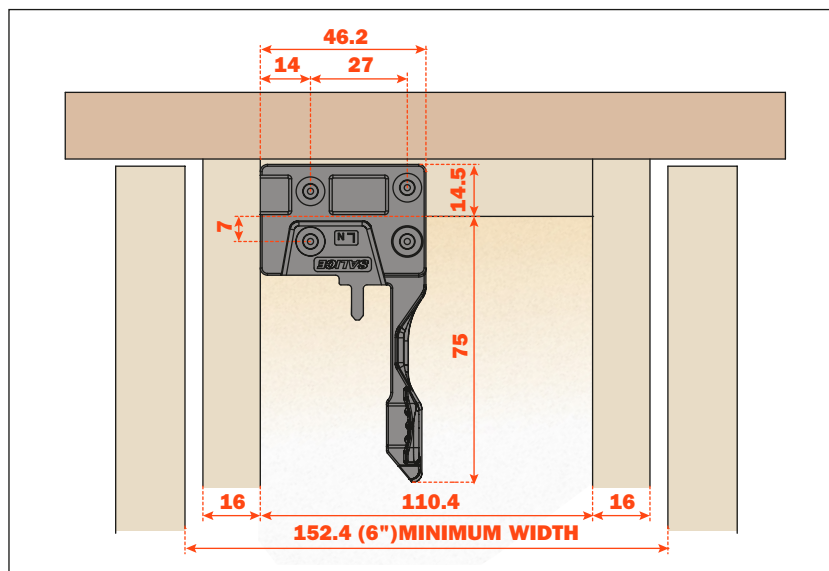

Assembly to the bottom

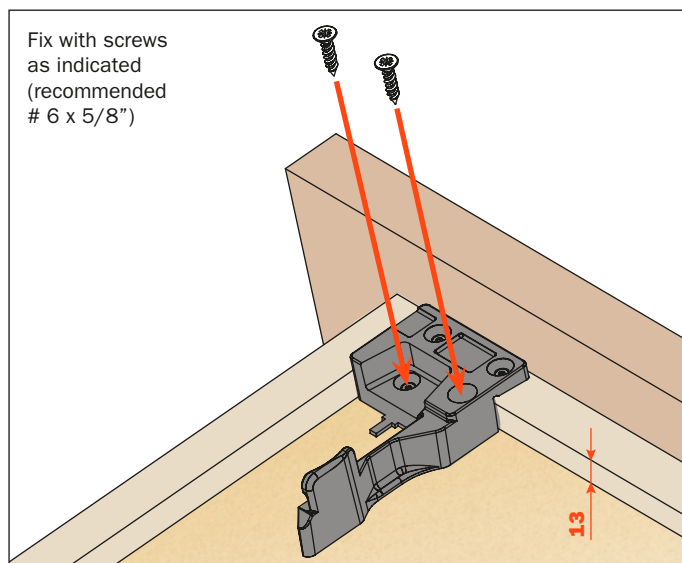

Use **drilling template** for accurate installation of the clips, see page 60.

Assembly to the drawer top side

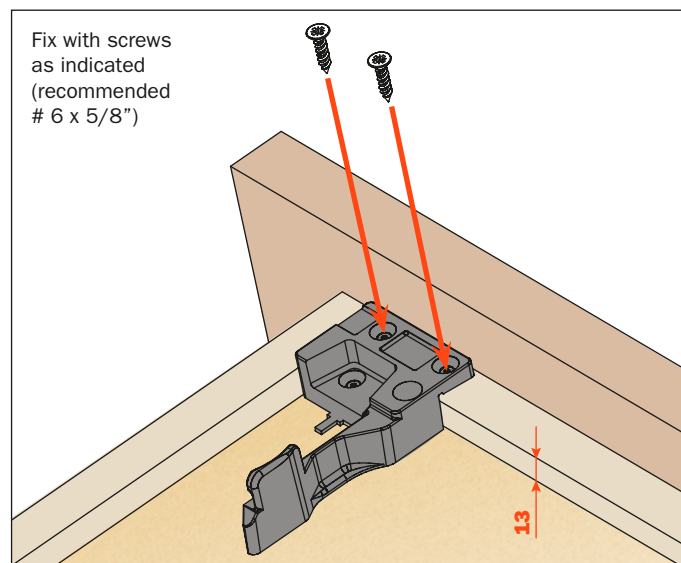

Use **drilling template** for accurate installation of the clips, see page 60.

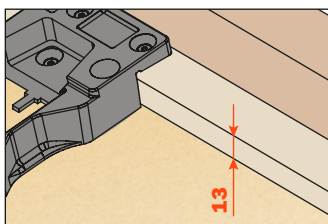

Height of the sub front must be 13 mm (1/2").

Drawer removal

Standard and vertical mount - 6-way adjustable - Side and depth adjustments

For all Progressa, Progressa+ and Progressa+ Shelf slides

Position hands under the front of the drawer and press on the orange levers, as indicated in the drawing, sliding the drawer out of the cabinet.

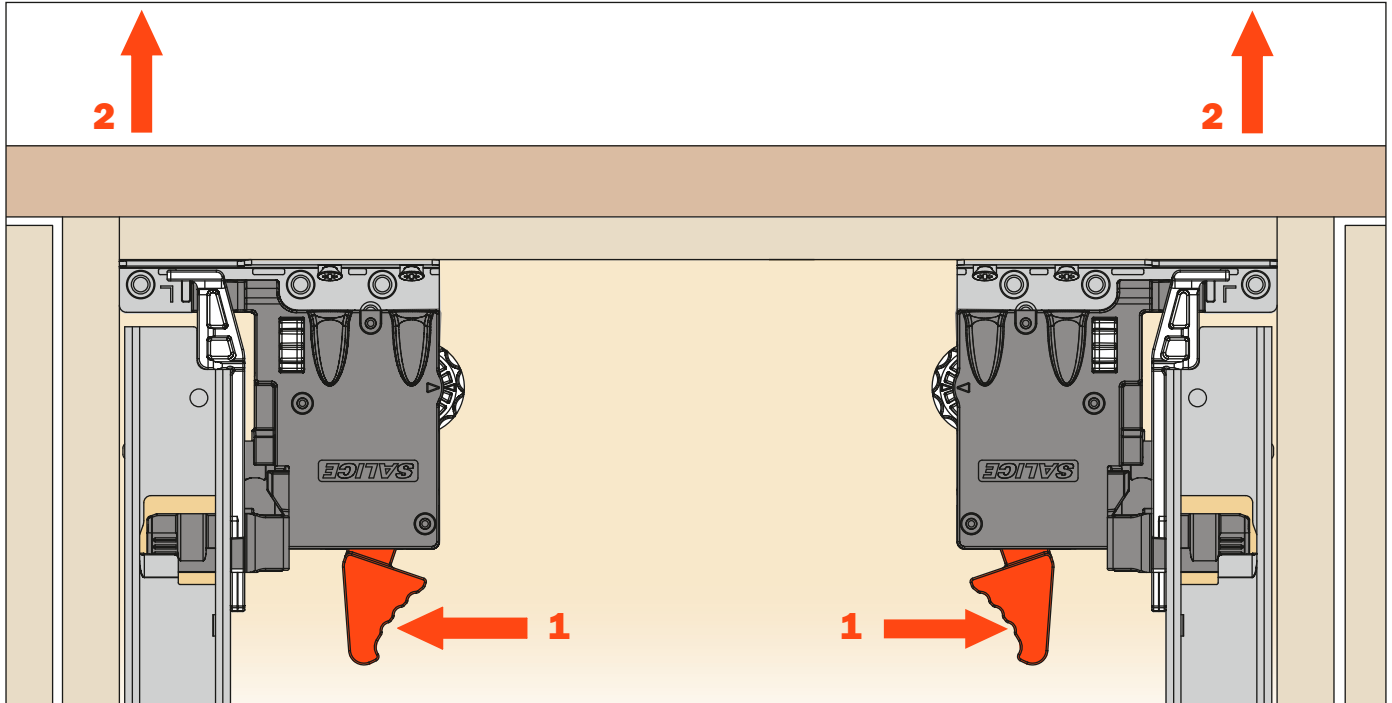

Standard mount - 2-way adjustable - Front and side fixing

For all Progressa, Progressa+ and Progressa+ Shelf slides

Position hands under the front of the drawer and press on the black levers, as indicated in the drawing, sliding the drawer out of the cabinet.

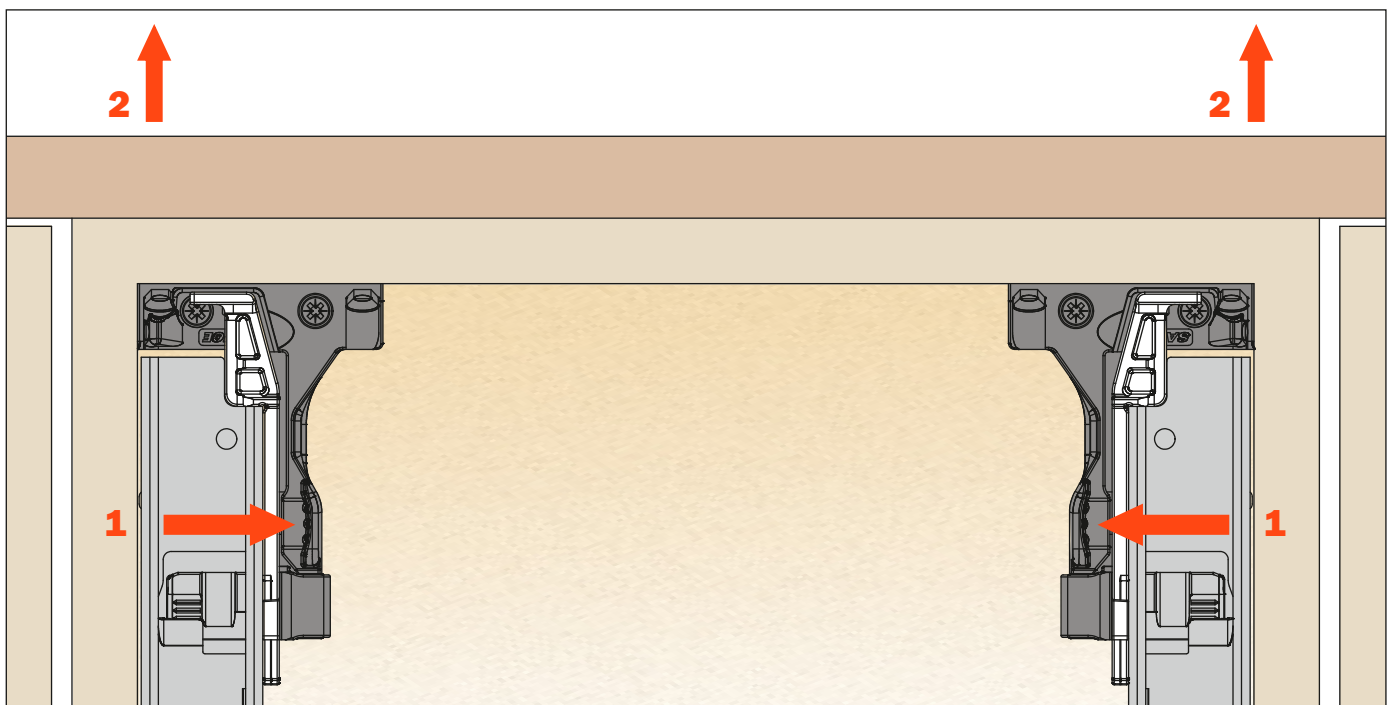

Narrow drawer clip

For all Progressa and Progressa+ slides

Position hands under the front of the drawer and press on the black levers, as indicated in the drawing, sliding the drawer out of the cabinet.

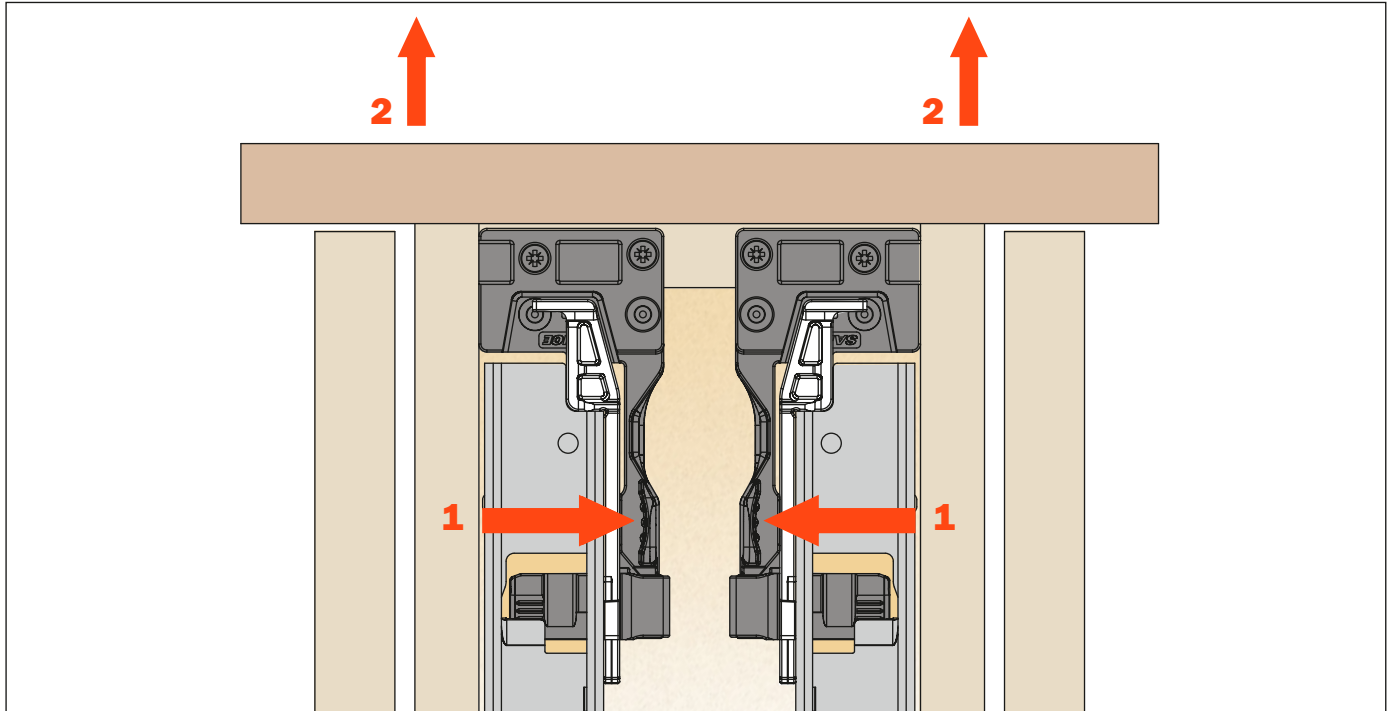

Side adjustment +/- 1.5 mm

For all Progressa, Progressa+ and Progressa+ Shelf slides

Rotate the white wheel (see drawing) towards the front of the drawer to adjust left.
This operation is tool free.

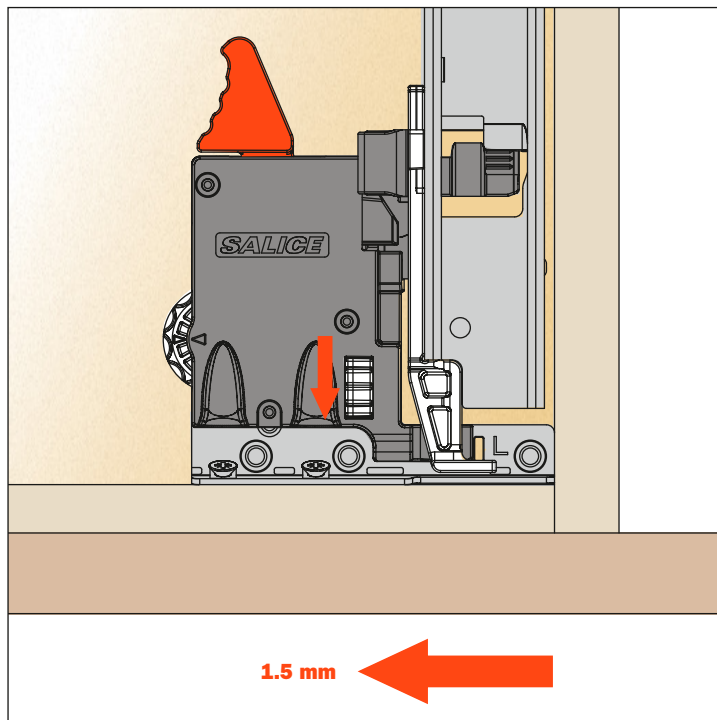
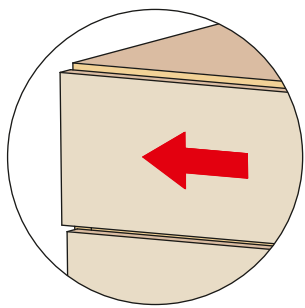
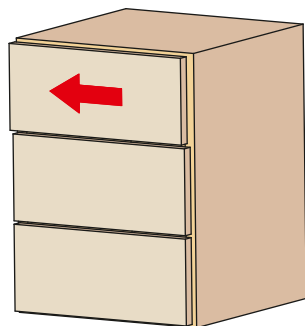

Rotate the white wheel (see drawing) towards the back of the drawer to adjust right.
This operation is tool free.

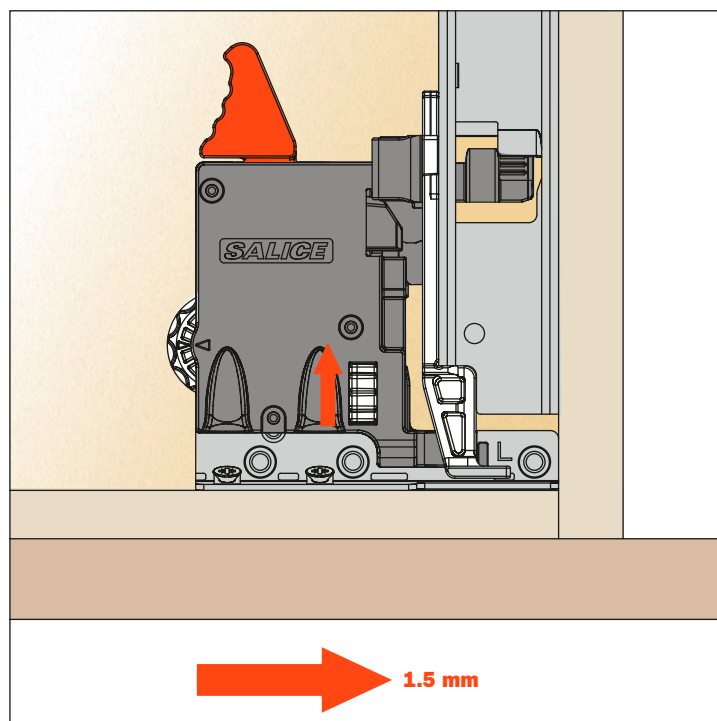
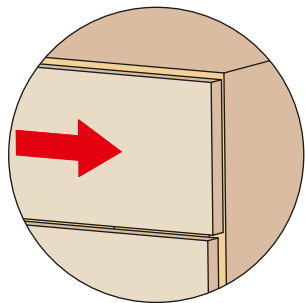
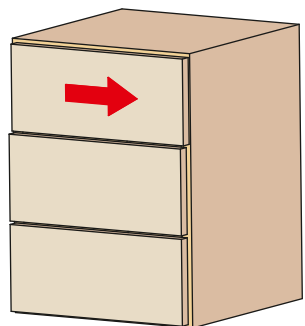

For side adjustment, it is recommended that both the adjusters on the clips are in the same direction, in order to maintain the correct alignment and function of the runners.

Depth adjustment +/- 3 mm

For all Progressa, Progressa+ and Progressa+ Shelf slides

Rotate the white wheel (see drawing) towards the outside of the drawer to increase the gap between the front and the side. This operation is tool free.

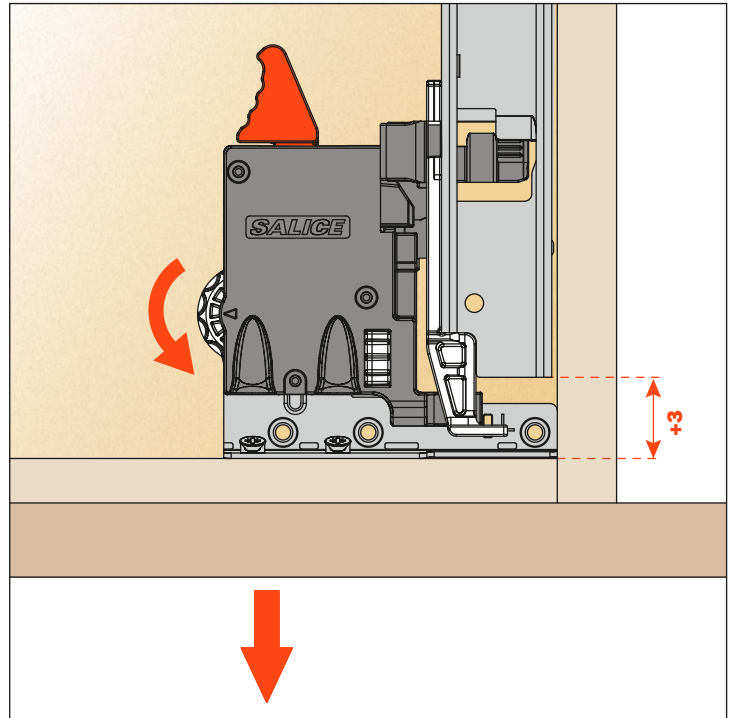
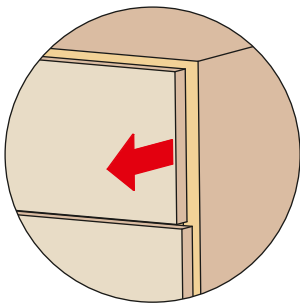
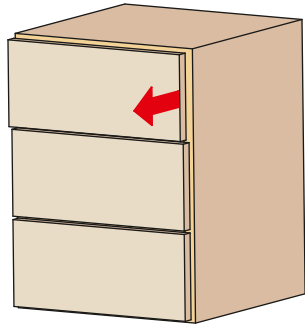

Rotate the white wheel (see drawing) towards the inside of the drawer to reduce the gap between the front and the side. This operation is tool free.

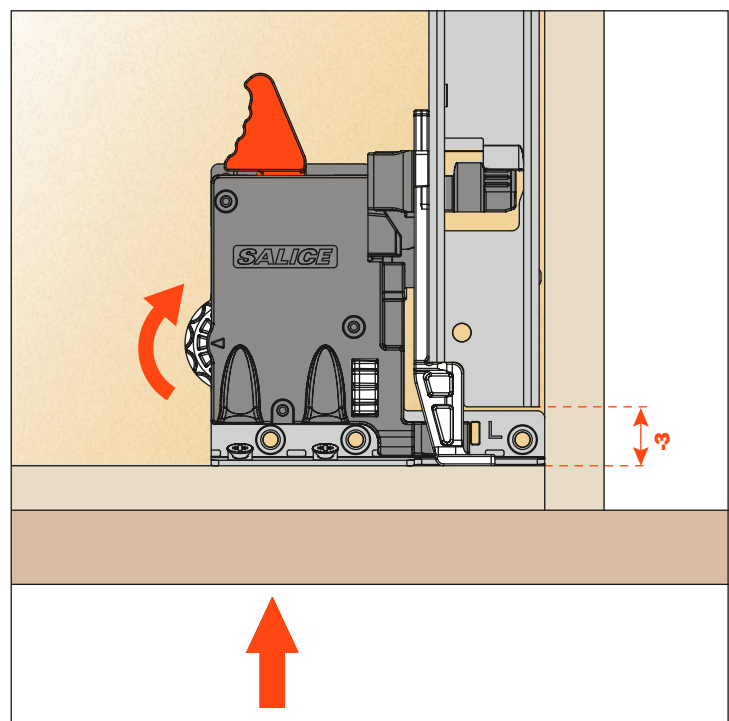
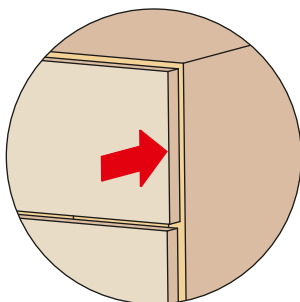
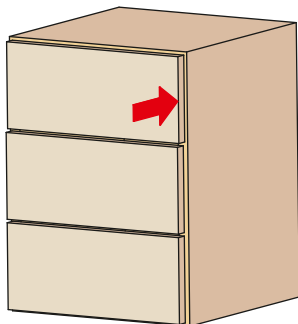

Progressa - Height adjustment + 2.5 mm

For all Progressa, Progressa+ and Progressa+ Shelf slides

Press the lever towards the back of the drawer to achieve the height adjustment.
This operation is tool free.

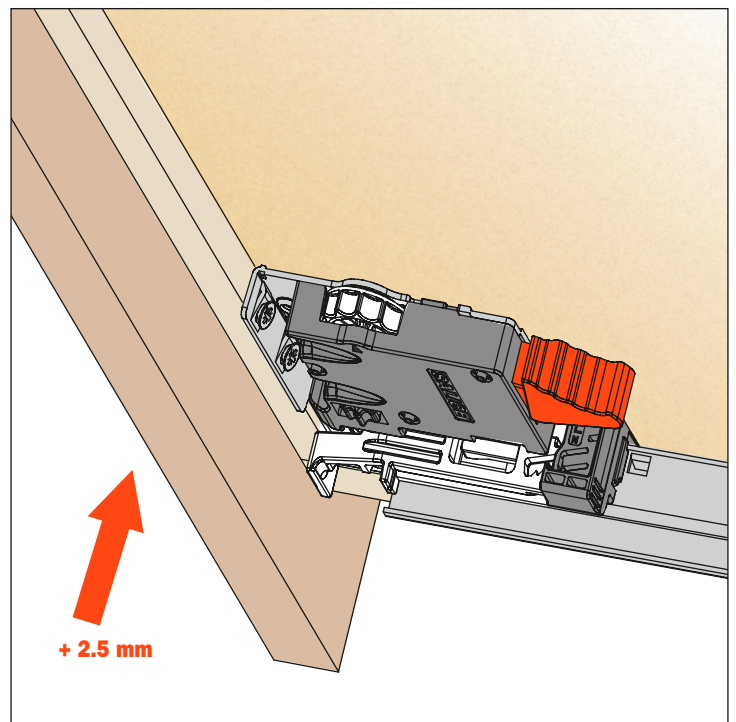
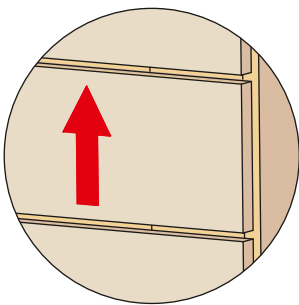
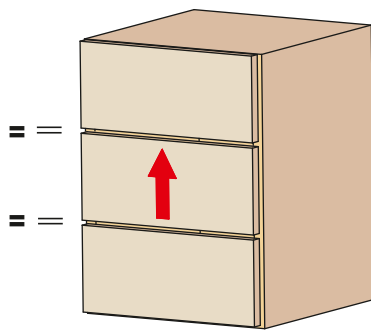
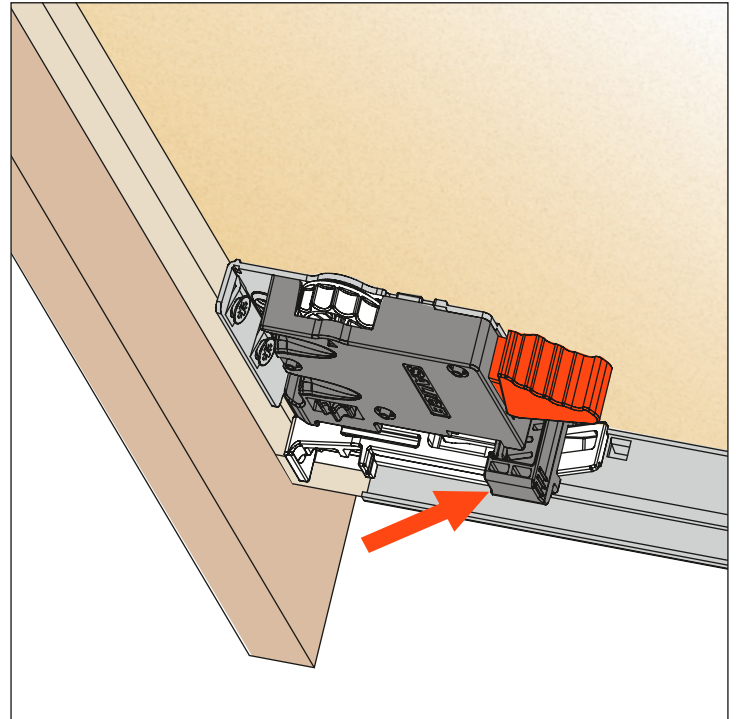
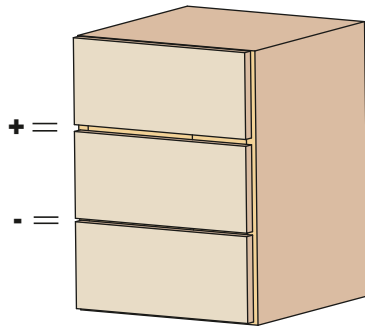

Assembly of tilt adjustment levers (optional)

For all Progressa and Progressa+ slides

Pull out the drawer and remove the plastic insert, both right and left.

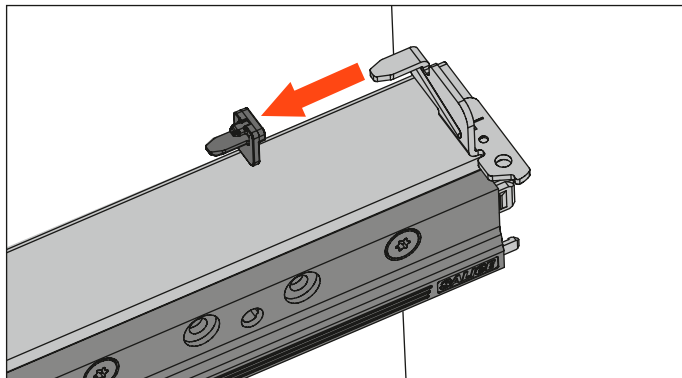

Insert the tilt adjustment levers, both right and left.

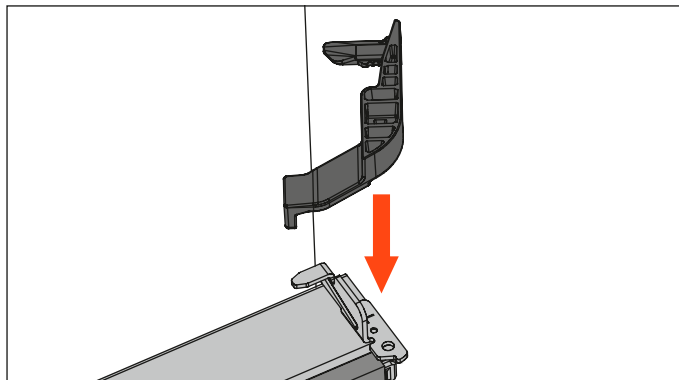

Rotate the lever to adjust.

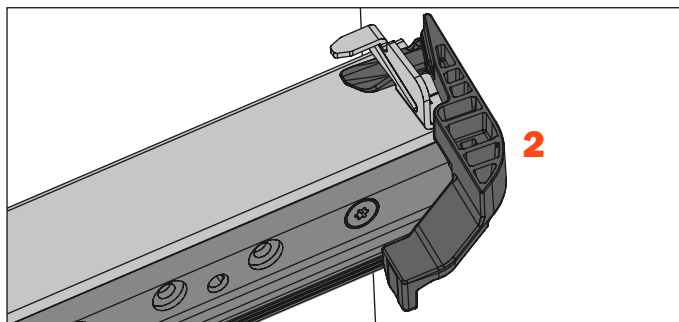
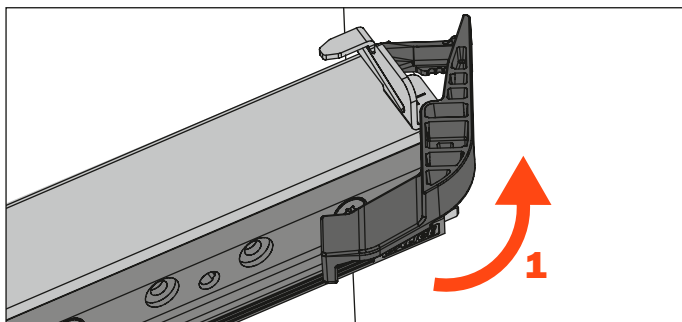

Tilt adjustment + 3 mm

Open the drawer (1) and press the lever towards the back of the cabinet (2) to achieve the adjustment.
Maximum 3 mm (1/8") rise of drawer back (tool free).

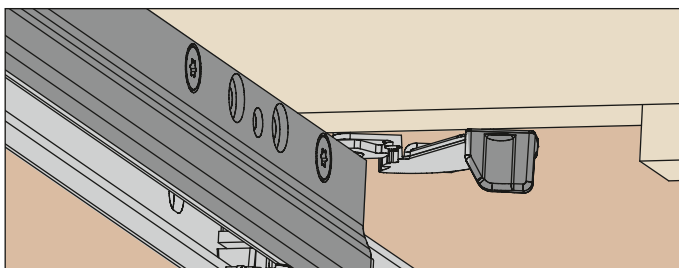
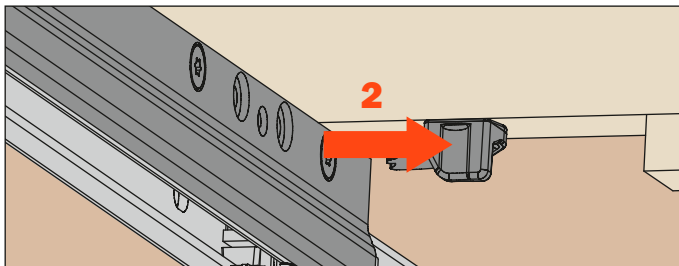
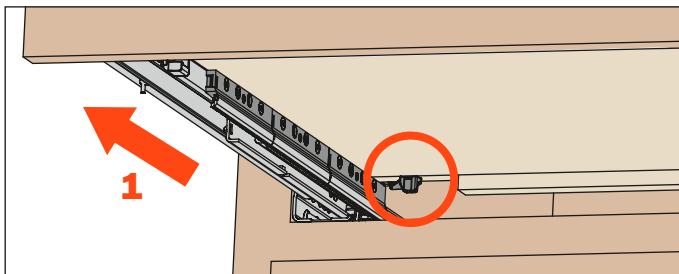
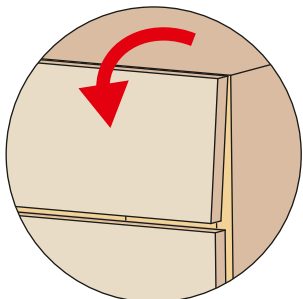
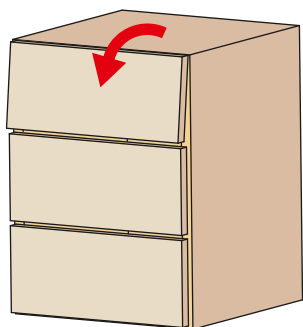

Drawer back preparation, see page 11.
AGLRXX3F tilt adjustment lever, see page 66.



Progressa Smove

Progressa - Full extension runner for 13 mm (1/2") to 16 mm (5/8") drawer material thickness
Smove



SMOVE: SOFT CLOSE MECHANISM FULLY INTEGRATED INTO THE DRAWER RUNNER

Product features

- 120 Lbs Static load capacity
- Full extension with a synchronized mechanism
- Enhanced smooth soft closing action
- Elongated holes for depth and height adjustment
- Adjustable clips allow for easy drawer insertion and removal
- Special clip for narrow drawers
- Tool free height adjustments + 2.5 mm
- Tool free depth adjustments +/- 3 mm
- Tool free side adjustments +/- 1.5 mm
- Meets and exceeds Ansi BHMA A156.9-2020 Grade 1 standard; WI approved
- Optional tool free tilt adjustment +3 mm
- 13 mm (1/2") to 16 mm (5/8") drawer material thickness
- Compatible with Lineabox drawers
- Finish: bright zinc-plated
- 100% Made in Italy

Dimensions

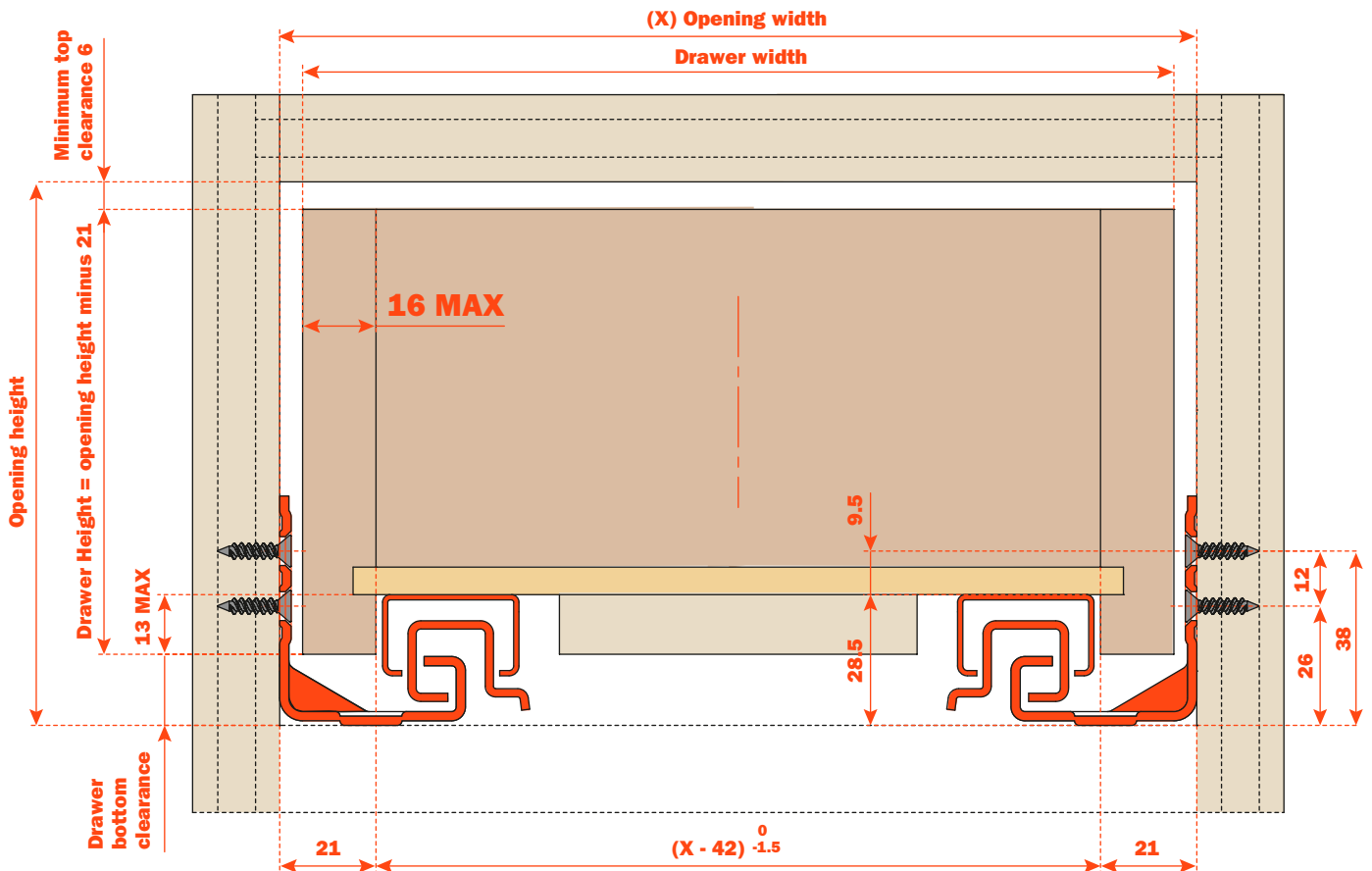

CALCULATION FORMULA FOR OUTSIDE DRAWER WIDTH

For drawer side thickness of	16 mm (5/8")	15 mm (19/32")	14 mm (9/16")	13 mm (1/2")	12 mm (7/16")
Deduct from inside cabinet width	10 mm (3/8")	12 mm (7/16")	14 mm (9/16")	16 mm (5/8")	18 mm (21/32")

Example: For a 15" inside cabinet width and a 5/8" thick drawer, subtract 3/8" from the inside width of 15" = 14-5/8" drawer width.

Note: Drawer side material thickness may vary. Make sure you take precise measurements when calculating outside drawer width using the table above. Inside drawer width must equal opening width minus 42 mm (1-21/32") for Progressa runners to align and function optimally.

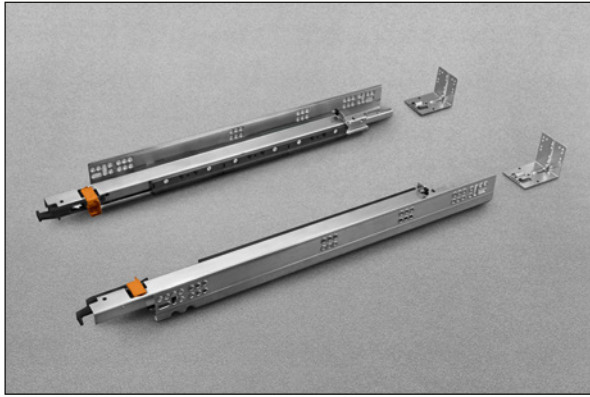

305X - 381X - 457X - 533X

Face frame assembly with socket

Blocked out face frame cabinets or frameless. See page 8.

Please note that any load over 75 LBS requires a filler in addition to rear sockets.

AFCGX3B
(right and left)



AFCGX43B
(right and left)



AFCEX56B
(right and left)



AFCEX43B
(right and left)

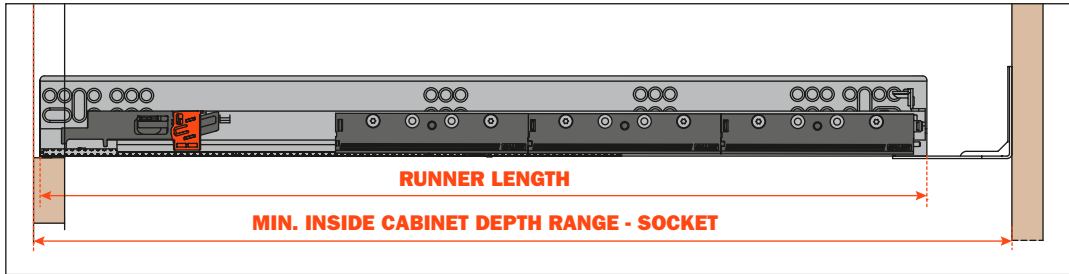

AGSK7C5B

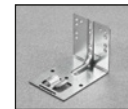

ASOG5G7AJYD



AGSK7R5B



ASOG5G7AJND



Use of rear sockets for any load above 75 Lbs is not recommended

PART NUMBER	DRAWER LENGTH (LC)	RUNNER LENGTH (LN)	MINIMUM INSIDE CABINET DEPTH	MINIMUM INSIDE CABINET DEPTH METAL SOCKET	MINIMUM INSIDE CABINET DEPTH PLASTIC SOCKET	MAXIMUM INSIDE CABINET DEPTH METAL/PLASTIC SOCKET
G5U6S305XXF6	305 mm (12")	314 mm	323 mm	326 mm	337 mm	360 mm
G5U6S381XXF6	381 mm (15")	390 mm	399 mm	402 mm	413 mm	447 mm
G5U6S457XXF6	457 mm (18")	466 mm	475 mm	478 mm	489 mm	523 mm
G5U6S533XXF6	533 mm (21")	542 mm	551 mm	554 mm	565 mm	599 mm



229C - 457C - 533C

Blocked out face frame cabinets or frameless. See page 9.

AFCGX3B
(right and left)



AFCGX43B
(right and left)



AFCEX56B
(right and left)



AFCEX43B
(right and left)

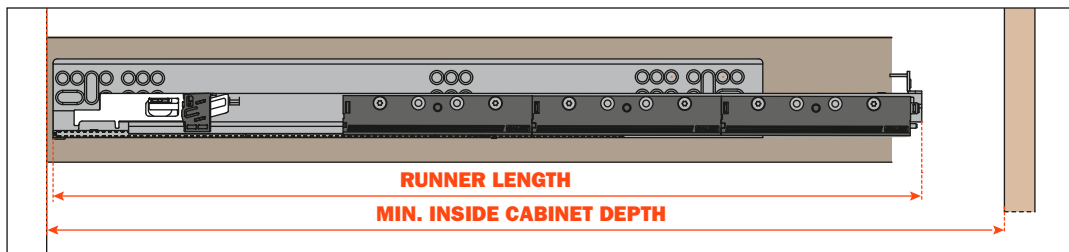

PART NUMBER	DRAWER LENGTH (LC)	RUNNER LENGTH (LN)	MINIMUM INSIDE CABINET DEPTH
G5U6S229CXF6	229 mm (9")	261 mm	270 mm
G5U6S457CXF6	457 mm (18")	465 mm	474 mm
G5U6S533CXF6	533 mm (21")	541 mm	550 mm

**Progressa - Full extension runner for 19 mm (3/4") drawer material thickness
Smove**



SMOVE: SOFT CLOSE MECHANISM FULLY INTEGRATED INTO THE DRAWER RUNNER

Product features

- 120 Lbs Static load capacity
- Full extension with a synchronized mechanism
- Enhanced smooth soft closing action
- Elongated holes for depth and height adjustment
- Adjustable clips allow for easy drawer insertion and removal
- Special clip for narrow drawers
- Tool free height adjustments + 2.5 mm
- Tool free depth adjustments +/- 3 mm
- Tool free side adjustments +/- 1.5 mm
- Meets and exceeds Ansi BHMA A156.9-2020 Grade 1 standard; WI approved
- Optional tool free tilt adjustment +3 mm
- 19 mm (3/4") drawer material thickness
- Compatible with Lineabox drawers
- Finish: bright zinc-plated
- 100% Made in Italy

Dimensions

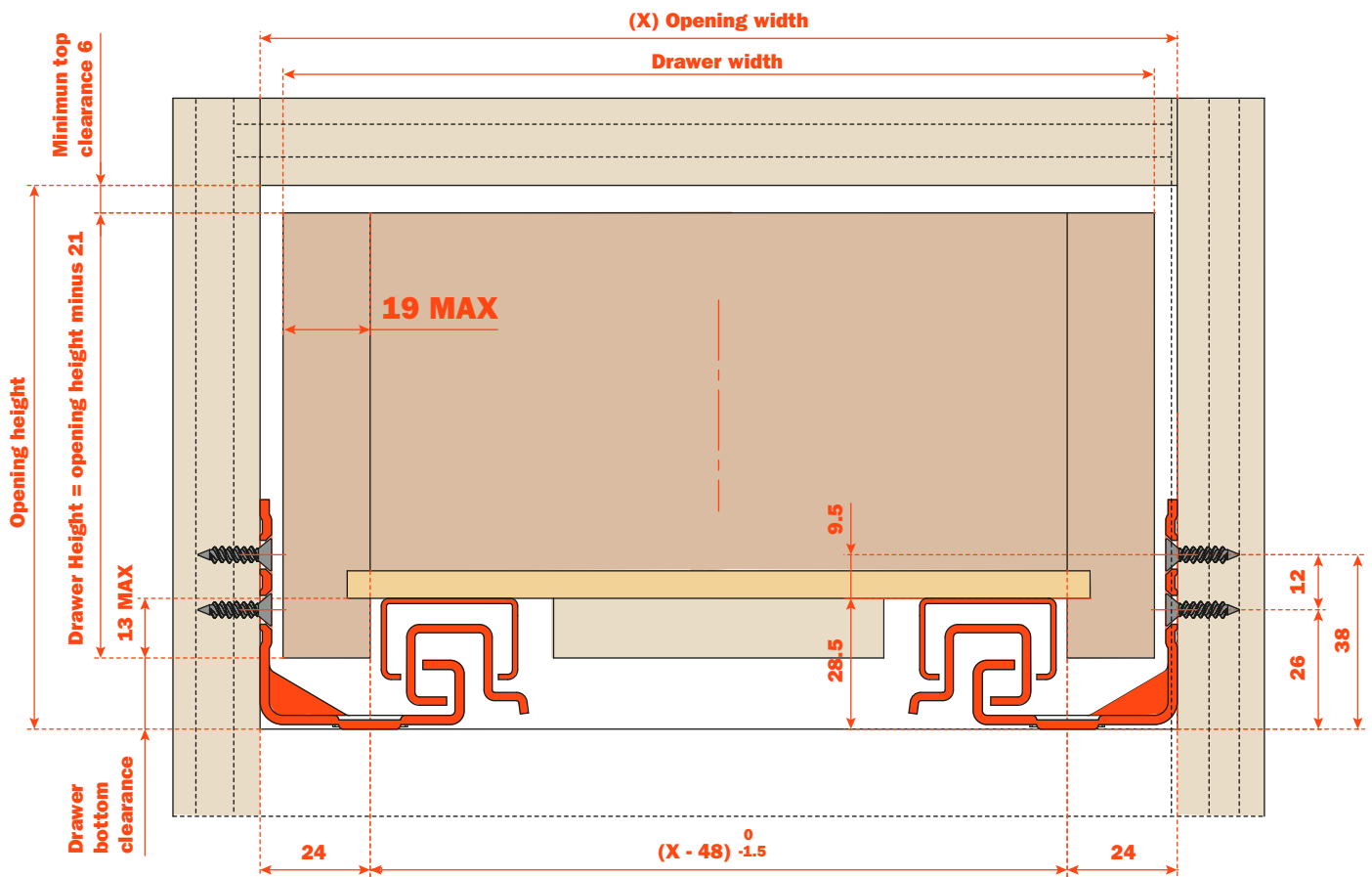

CALCULATION FORMULA FOR OUTSIDE DRAWER WIDTH

For drawer side thickness of	19 mm (3/4")	18 mm (45/64")	17 mm (43/64")	16 mm (5/8")	
Deduct from inside cabinet width	10 mm (3/8")	12 mm (7/16")	14 mm (9/16")	16 mm (5/8")	

Example: For a 15" inside cabinet width and a 3/4" thick drawer, subtract 3/8" from the inside width of 15" = 14-5/8" drawer width.

Note: Drawer side material thickness may vary. Make sure you take precise measurements when calculating outside drawer width using the table above. Inside drawer width must equal opening width minus 48 mm (1-57/64") for Progressa runners to align and function optimally.

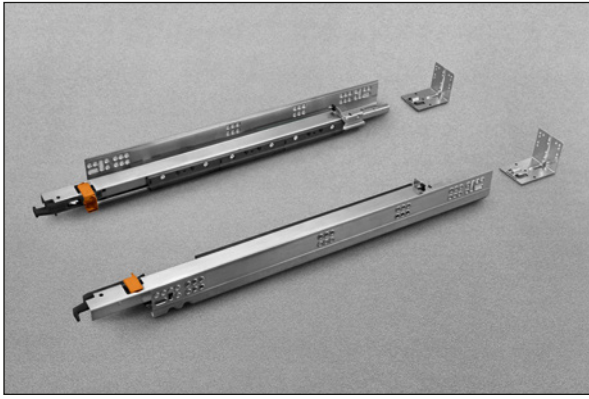

381X - 457X - 533X

Face frame assembly with socket

Blocked out face frame cabinets or frameless. See page 8.

AFCGX3B
(right and left)



AFCGX43B
(right and left)



AFCEX56B
(right and left)



AFCEX43B
(right and left)

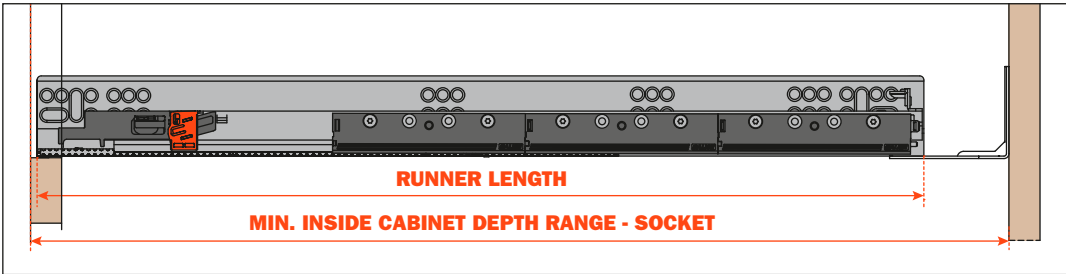

AGSK7C5B

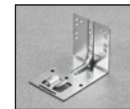

ASOG5G7AJYD



AGSK7R5B



ASOG5G7AJND



Use of rear sockets for any load above 75 Lbs is not recommended

PART NUMBER	DRAWER LENGTH (LC)	RUNNER LENGTH (LN)	MINIMUM INSIDE CABINET DEPTH	MINIMUM INSIDE CABINET DEPTH METAL SOCKET	MINIMUM INSIDE CABINET DEPTH PLASTIC SOCKET	MAXIMUM INSIDE CABINET DEPTH METAL/PLASTIC SOCKET
G5U9S381XXF6	381 mm (15")	392 mm	401 mm	404 mm	415 mm	447 mm
G5U9S457XXF6	457 mm (18")	468 mm	477 mm	480 mm	491 mm	523 mm
G5U9S533XXF6	533 mm (21")	544 mm	553 mm	556 mm	567 mm	599 mm



457C - 533C

Blocked out face frame cabinets or frameless. See page 9.

AFCGX3B
(right and left)



AFCGX43B
(right and left)



AFCEX56B
(right and left)



AFCEX43B
(right and left)

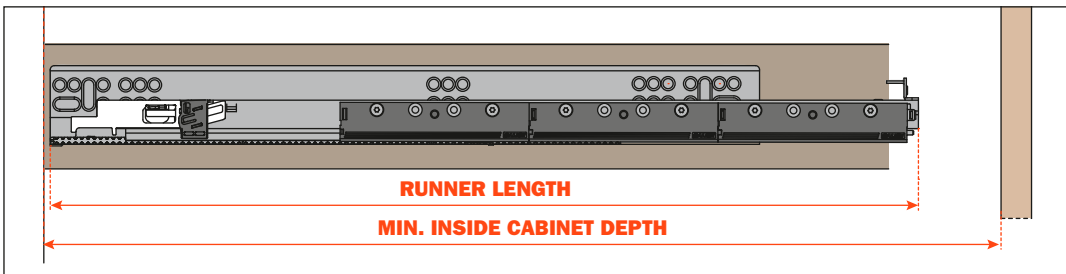

PART NUMBER	DRAWER LENGTH (LC)	RUNNER LENGTH (LN)	MINIMUM INSIDE CABINET DEPTH
G5U9S457CXF6	457 mm (18")	468 mm	477 mm
G5U9S533CXF6	533 mm (21")	544 mm	553 mm



Progressa+ Smove

Progressa+ - Full extension runner for 13 mm (1/2") to 16 mm (5/8") drawer material thickness
Smove



SMOVE: SOFT CLOSE MECHANISM FULLY INTEGRATED INTO THE DRAWER RUNNER

Product features

- 170 Lbs Static load capacity
- Full extension with a synchronized mechanism
- Enhanced smooth soft closing action
- Elongated holes for depth and height adjustment
- Adjustable clips allow for easy drawer insertion and removal
- Special clip for narrow drawers
- Tool free height adjustments + 2.5 mm
- Tool free depth adjustments +/- 3 mm
- Tool free side adjustments +/- 1.5 mm
- Meets and exceeds Ansi BHMA A156.9-2020 Grade 1 standard; WI approved
- Optional tool free tilt adjustment +3 mm
- 13 mm (1/2") to 16 mm (5/8") drawer material thickness
- Compatible with Lineabox drawers
- Finish: bright zinc-plated
- 100% Made in Italy

Dimensions

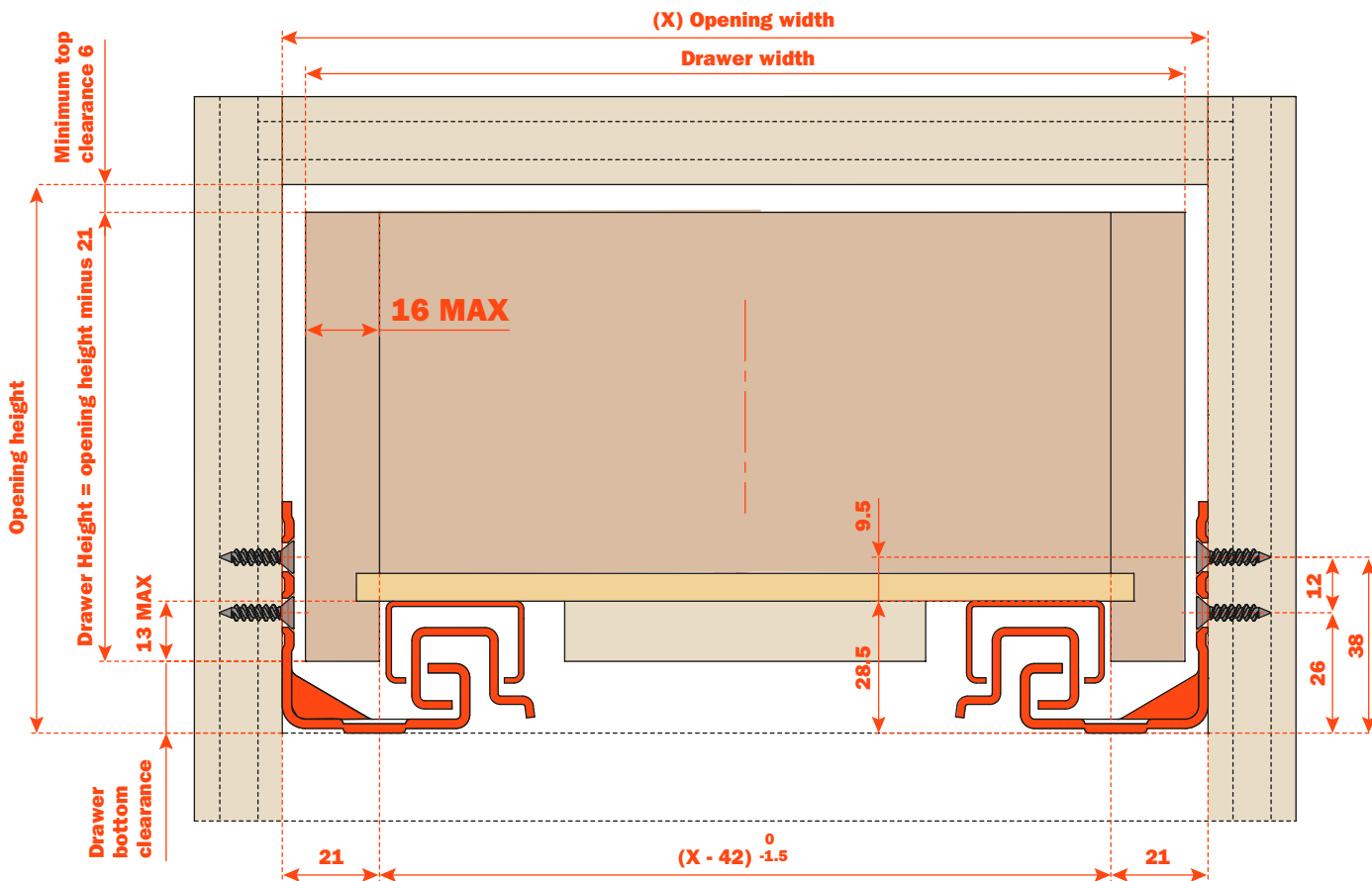

CALCULATION FORMULA FOR OUTSIDE DRAWER WIDTH

For drawer side thickness of	16 mm (5/8")	15 mm (19/32")	14 mm (9/16")	13 mm (1/2")	12 mm (7/16")
Deduct from inside cabinet width	10 mm (3/8")	12 mm (7/16")	14 mm (9/16")	16 mm (5/8")	18 mm (21/32")

Example: For a 15" inside cabinet width and a 5/8" thick drawer, subtract 3/8" from the inside width of 15" = 14-5/8" drawer width.

Note: Drawer side material thickness may vary. Make sure you take precise measurements when calculating outside drawer width using the table above. Inside drawer width must equal opening width minus 42 mm (1-21/32") for Progressa+ runners to align and function optimally.

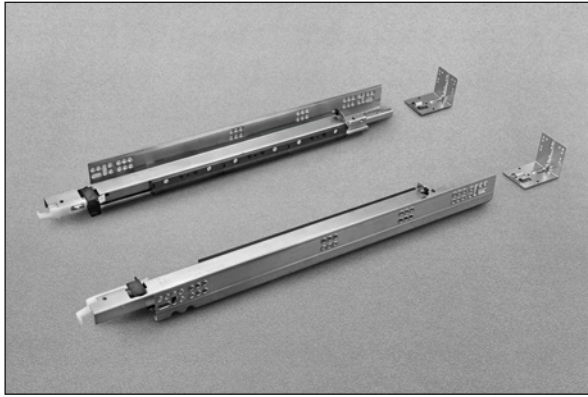

381X - 457X - 533X

Face frame assembly with metal socket

Blocked out face frame cabinets or frameless. See page 8.

Please note that any load over 75 LBS requires a filler in addition to rear sockets.

AFCGX3B
(right and left)



AFCGX43B
(right and left)



AFCX56B
(right and left)



AFCX43B
(right and left)

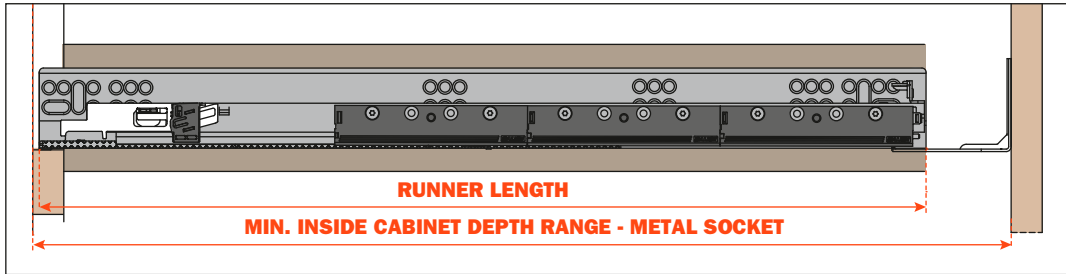

AGSK7C5B

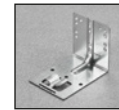

AGSK7R5B

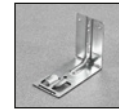

Use of rear sockets for any load above 75 Lbs is not recommended

PART NUMBER	DRAWER LENGTH (LC)	RUNNER LENGTH (LN)	MINIMUM INSIDE CABINET DEPTH	MINIMUM INSIDE CABINET DEPTH METAL SOCKET	MAXIMUM INSIDE CABINET DEPTH METAL SOCKET
G7U6S381XXF6	381 mm (15")	390 mm	399 mm	402 mm	447 mm
G7U6S457XXF6	457 mm (18")	466 mm	475 mm	478 mm	523 mm
G7U6S533XXF6	533 mm (21")	542 mm	551 mm	554 mm	599 mm



457C - 533C - 610C - 686C - 762C

Blocked out face frame cabinets or frameless. See page 9.

AFCGX3B
(right and left)



AFCGX43B
(right and left)



AFCX56B
(right and left)

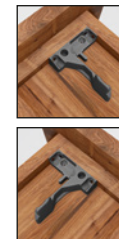

AFCX43B
(right and left)

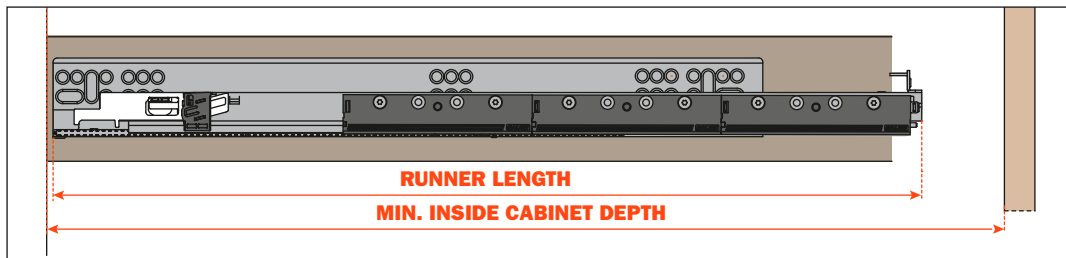

PART NUMBER	DRAWER LENGTH (LC)	RUNNER LENGTH (LN)	MINIMUM INSIDE CABINET DEPTH
G7U6S457CXF6	457 mm (18")	465 mm	474 mm
G7U6S533CXF6	533 mm (21")	541 mm	550 mm
G7U6S610CXF2	610 mm (24")	618 mm	627 mm
G7U6S686CXF2	686 mm (27")	694 mm	703 mm
G7U6S762CXF2	762 mm (30")	770 mm	779 mm

Progressa+ - Full extension runner for 19 mm (3/4") drawer material thickness
Smove



SMOVE: SOFT CLOSE MECHANISM FULLY INTEGRATED INTO THE DRAWER RUNNER

Product features

- 170 Lbs Static load capacity
- Full extension with a synchronized mechanism
- Enhanced smooth soft closing action
- Elongated holes for depth and height adjustment
- Adjustable clips allow for easy drawer insertion and removal;
- Special clip for narrow drawers
- Tool free height adjustments + 2.5 mm
- Tool free depth adjustments +/- 3 mm
- Tool free side adjustments +/- 1.5 mm
- Meets and exceeds Ansi BHMA A156.9-2020 Grade 1 standard; WI approved
- Optional tool free tilt adjustment +3 mm
- 19 mm (3/4") drawer material thickness
- Compatible with Lineabox drawers
- Finish: bright zinc-plated
- 100% Made in Italy

Dimensions

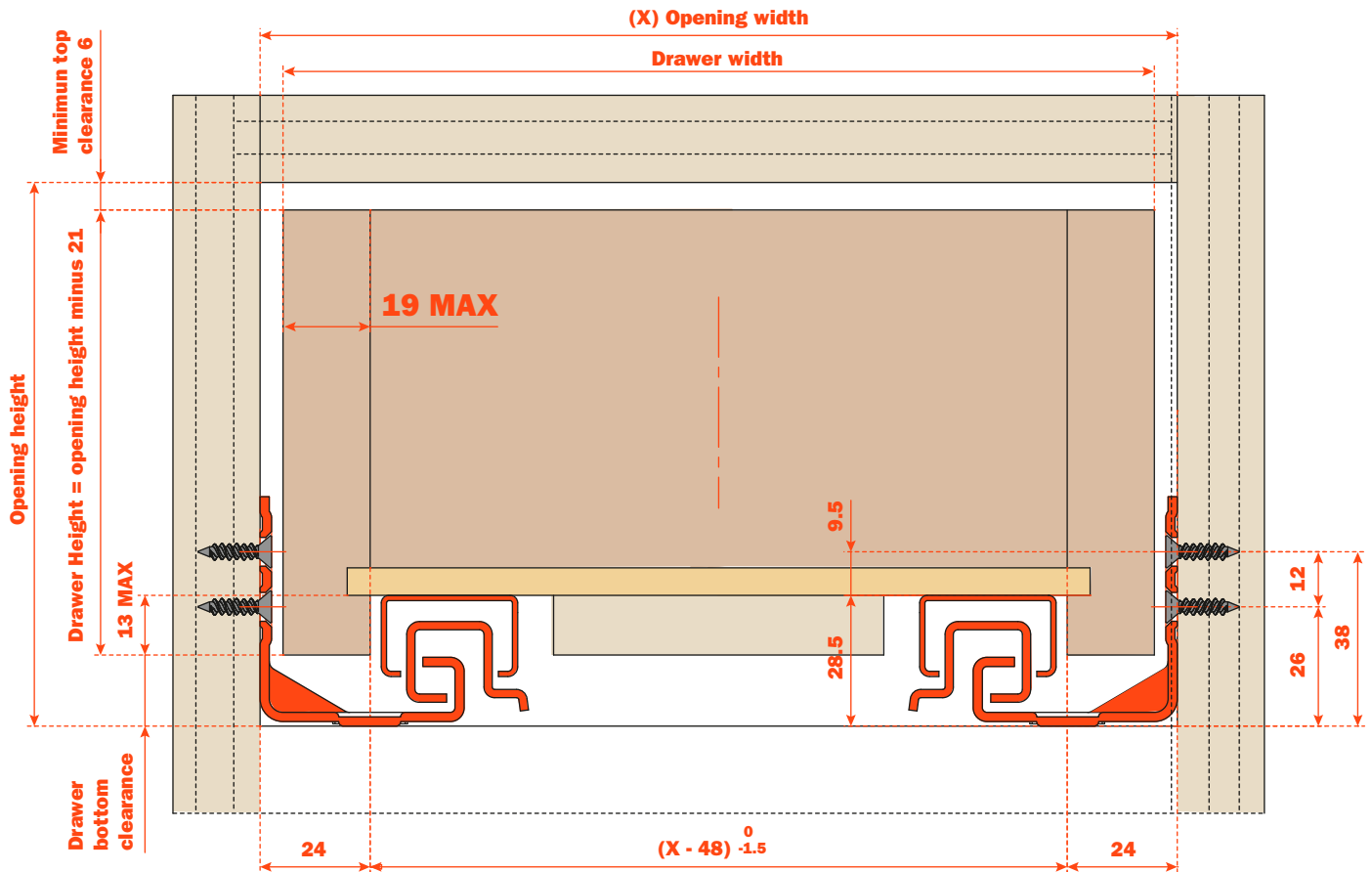

CALCULATION FORMULA FOR OUTSIDE DRAWER WIDTH

For drawer side thickness of	19 mm (3/4")	18 mm (45/64")	17 mm (43/64")	16 mm (5/8")	
Deduct from inside cabinet width	10 mm (3/8")	12 mm (7/16")	14 mm (9/16")	16 mm (5/8")	

Example: For a 15" inside cabinet width and a 3/4" thick drawer, subtract 3/8" from the inside width of 15" = 14-5/8" drawer width.

Note: Drawer side material thickness may vary. Make sure you take precise measurements when calculating outside drawer width using the table above. Inside drawer width must equal opening width minus 48 mm (1-57/64") for Progressa+ runners to align and function optimally.

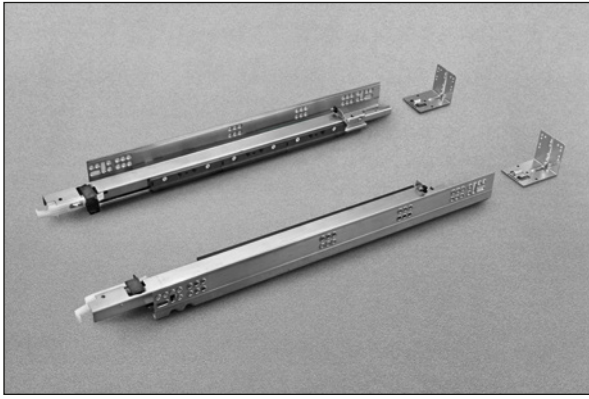

381X - 457X - 533X

Face frame assembly with metal socket

Blocked out face frame cabinets or frameless. See page 8.

AFCGX3B
(right and left)



AFCGX43B
(right and left)



AFCX56B
(right and left)



AFCX43B
(right and left)

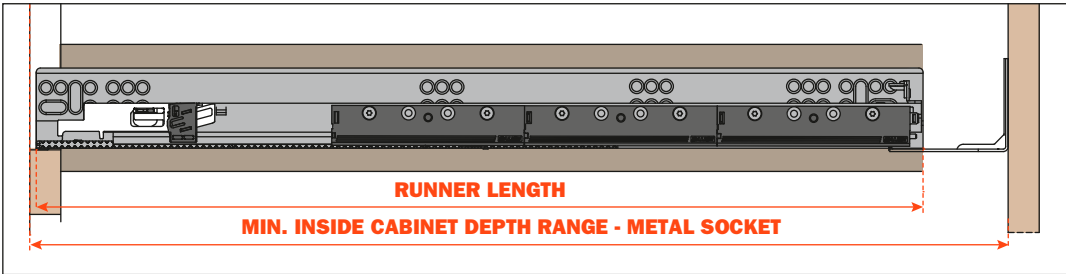

AGSK7C5B

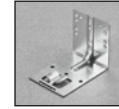

AGSK7R5B

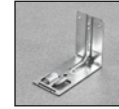

Use of rear sockets for any load above 75 Lbs is not recommended

PART NUMBER	DRAWER LENGTH (LC)	RUNNER LENGTH (LN)	MINIMUM INSIDE CABINET DEPTH	MINIMUM INSIDE CABINET DEPTH METAL SOCKET	MAXIMUM INSIDE CABINET DEPTH METAL SOCKET
G7U9S381XXF6	381 mm (15")	392 mm	401 mm	404 mm	447 mm
G7U9S457XXF6	457 mm (18")	468 mm	477 mm	480 mm	523 mm
G7U9S533XXF6	533 mm (21")	544 mm	553 mm	556 mm	599 mm



457C - 533C - 610C - 686C - 762C

Blocked out face frame cabinets or frameless. See page 9.

AFCGX3B
(right and left)



AFCGX43B
(right and left)



AFCX56B
(right and left)



AFCX43B
(right and left)

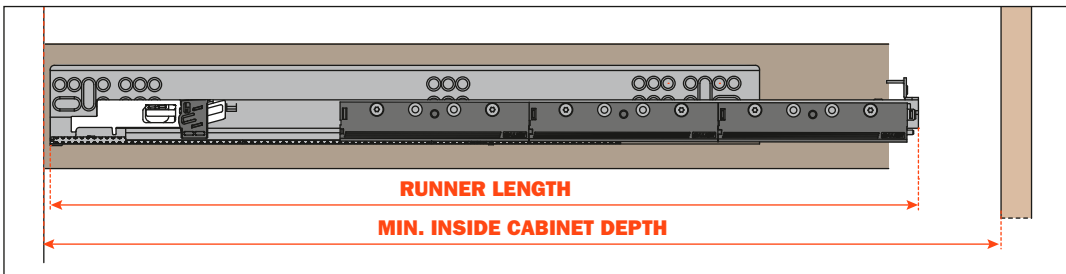

PART NUMBER	DRAWER LENGTH (LC)	RUNNER LENGTH (LN)	MINIMUM INSIDE CABINET DEPTH
G7U9S457CXF6	457 mm (18")	468 mm	477 mm
G7U9S533CXF6	533 mm (21")	544 mm	553 mm
G7U9S610CXF2	610 mm (24")	621 mm	630 mm
G7U9S686CXF2	686 mm (27")	697 mm	706 mm
G7U9S762CXF2	762 mm (30")	773 mm	782 mm



Progressa+
Push to open

Progressa+ - Full extension runner for 13 mm (1/2") to 16 mm (5/8") drawer material thickness
Push to open



PUSH: THE OPENING SYSTEM FOR HANDLE-LESS DRAWERS IS FULLY INTEGRATED IN THE RUNNER.
A SLIGHT PRESSURE OF THE DRAWER FRONT IS ENOUGH FOR THE DRAWER TO OPEN.

Product features

- 170 Lbs Static load capacity
- Full extension with a synchronized mechanism
- Integrated Push opening system
- Elongated holes for depth and height adjustment
- Adjustable clips allow for easy drawer insertion and removal
- Special clip for narrow drawers
- The drawer is latched when closed
- Frameless or blocked out face frame applications
- Tool free height adjustments + 2.5 mm
- Tool free depth adjustments +/- 3 mm
- Tool free side adjustments +/- 1.5 mm
- Meets and exceeds Ansi BHMA A156.9-2020 Grade 1 standard; WI approved
- Optional:
 - tool free tilt adjustment +3 mm
 - Push Synchronizer
- 13 mm (1/2") to 16 mm (5/8") drawer material thickness
- Compatible with Lineabox drawers
- Finish: bright zinc-plated
- 100% Made in Italy

Dimensions

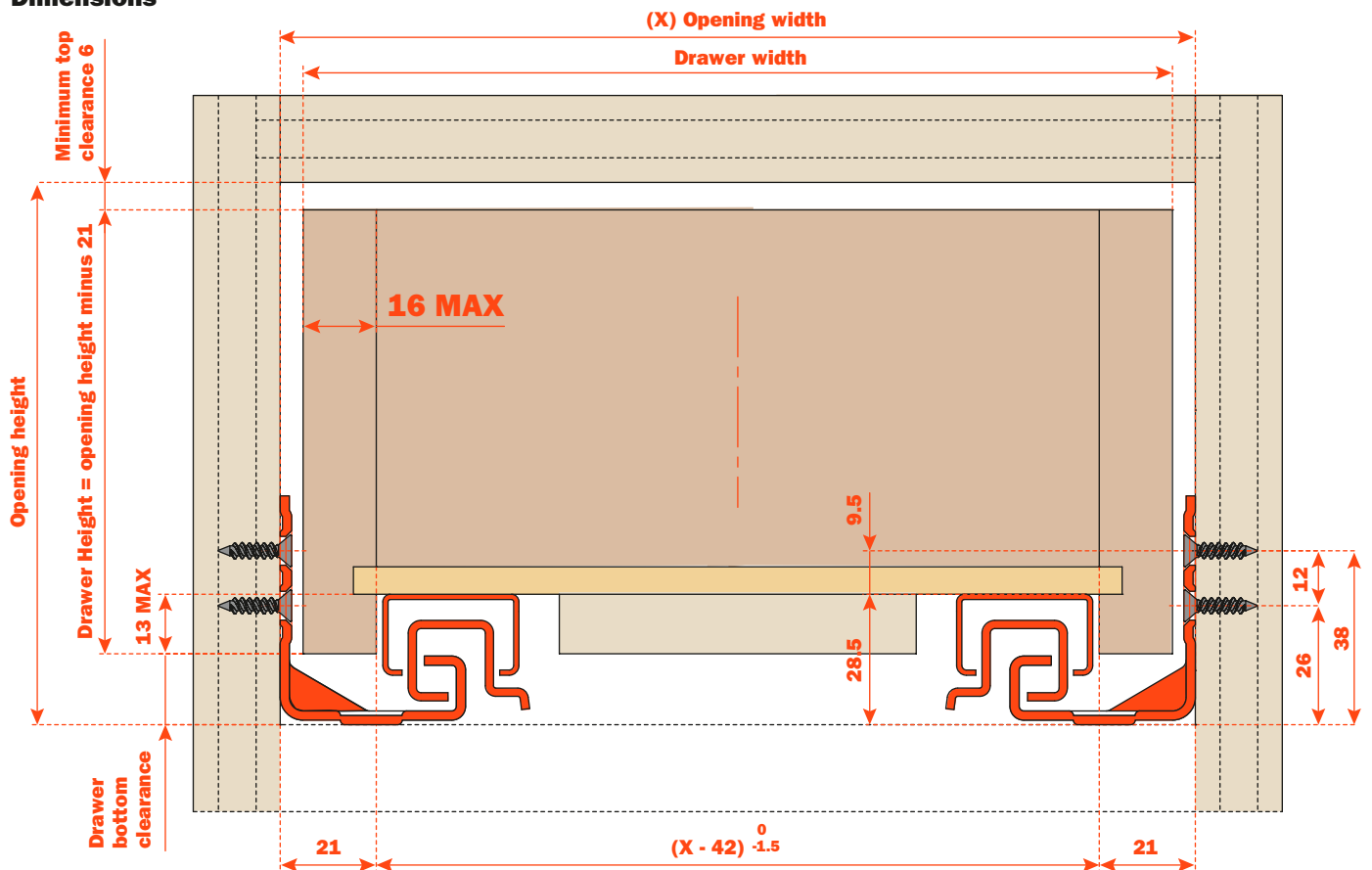

CALCULATION FORMULA FOR OUTSIDE DRAWER WIDTH

For drawer side thickness of	16 mm (5/8")	15 mm (19/32")	14 mm (9/16")	13 mm (1/2")	12 mm (7/16")
Deduct from inside cabinet width	10 mm (3/8")	12 mm (7/16")	14 mm (9/16")	16 mm (5/8")	18 mm (21/32")

Example: For a 15" inside cabinet width and a 5/8" thick drawer, subtract 3/8" from the inside width of 15" = 14-5/8" drawer width.

Note: Drawer side material thickness may vary. Make sure you take precise measurements when calculating outside drawer width using the table above. Inside drawer width must equal opening width minus 42 mm (1-21/32") for Progressa+ runners to align and function optimally.

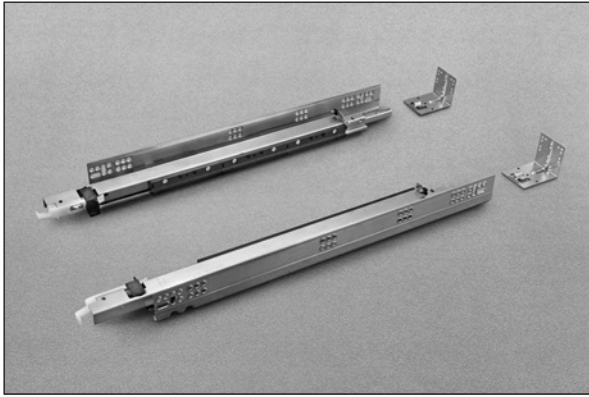

381X - 457X - 533X

Blocked out face frame cabinets or frameless

The socket can be used for the correct alignment of the runners before fixing to the cabinet side. See page 8.

AFCGX3B
(right and left)



AFCGX43B
(right and left)

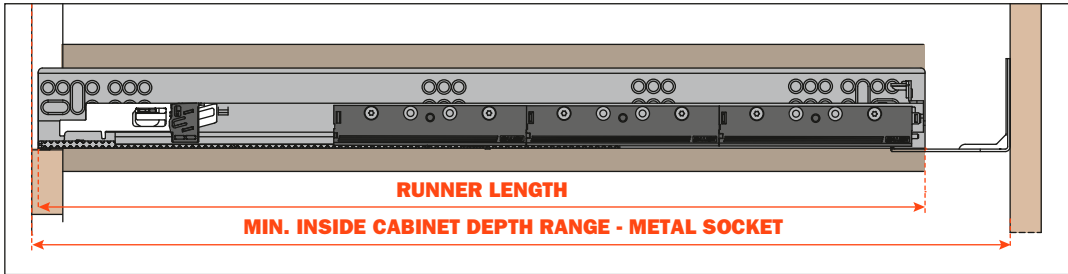

AGSK7C5B

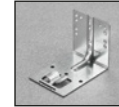

AGSK7R5B

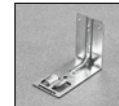

Use of rear sockets for any load above 75 Lbs is not recommended

PART NUMBER	DRAWER LENGTH (LC)	RUNNER LENGTH (LN)	MINIMUM INSIDE CABINET DEPTH	MINIMUM INSIDE CABINET DEPTH METAL SOCKET	MAXIMUM INSIDE CABINET DEPTH METAL SOCKET
G7U6P381XXF6	381 mm (15")	390 mm	399 mm	402 mm	447 mm
G7U6P457XXF6	457 mm (18")	466 mm	475 mm	478 mm	523 mm
G7U6P533XXF6	533 mm (21")	542 mm	551 mm	554 mm	599 mm



457C - 533C - 610C - 686C - 762C

Blocked out face frame cabinets or frameless. See page 9.

AFCGX3B
(right and left)



AFCGX43B
(right and left)

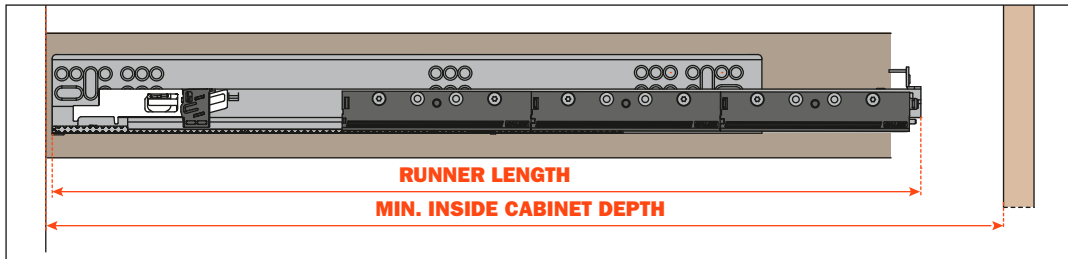

PART NUMBER	DRAWER LENGTH (LC)	RUNNER LENGTH (LN)	MINIMUM INSIDE CABINET DEPTH
G7U6P457CXF6	457 mm (18")	465 mm	474 mm
G7U6P533CXF6	533 mm (21")	541 mm	550 mm
G7U6P610CXF2	610 mm (24")	618 mm	627 mm
G7U6P686CXF2	686 mm (27")	694 mm	703 mm
G7U6P762CXF2	762 mm (30")	770 mm	779 mm

Progressa+ - Full extension runner for 19 mm (3/4") drawer material thickness
Push to open



PUSH: THE OPENING SYSTEM FOR HANDLE-LESS DRAWERS IS FULLY INTEGRATED IN THE RUNNER.
A SLIGHT PRESSURE OF THE DRAWER FRONT IS ENOUGH FOR THE DRAWER TO OPEN.

Product features

- 170 Lbs Static load capacity
- Full extension with a synchronized mechanism
- Integrated Push opening system
- Elongated holes for depth and height adjustment
- Adjustable clips allow for easy drawer insertion and removal
- Special clip for narrow drawers
- The drawer is latched when closed
- Frameless or blocked out face frame applications
- Tool free height adjustments + 2.5 mm
- Tool free depth adjustments +/- 3 mm
- Tool free side adjustments +/- 1.5 mm
- Meets and exceeds Ansi BHMA A156.9-2020 Grade 1 standard; WI approved
- Optional:
 - tool free tilt adjustment +3 mm
 - Push Synchronizer
- 19 mm (3/4") drawer material thickness
- Compatible with Lineabox drawers
- Finish: bright zinc-plated
- 100% Made in Italy

Dimensions

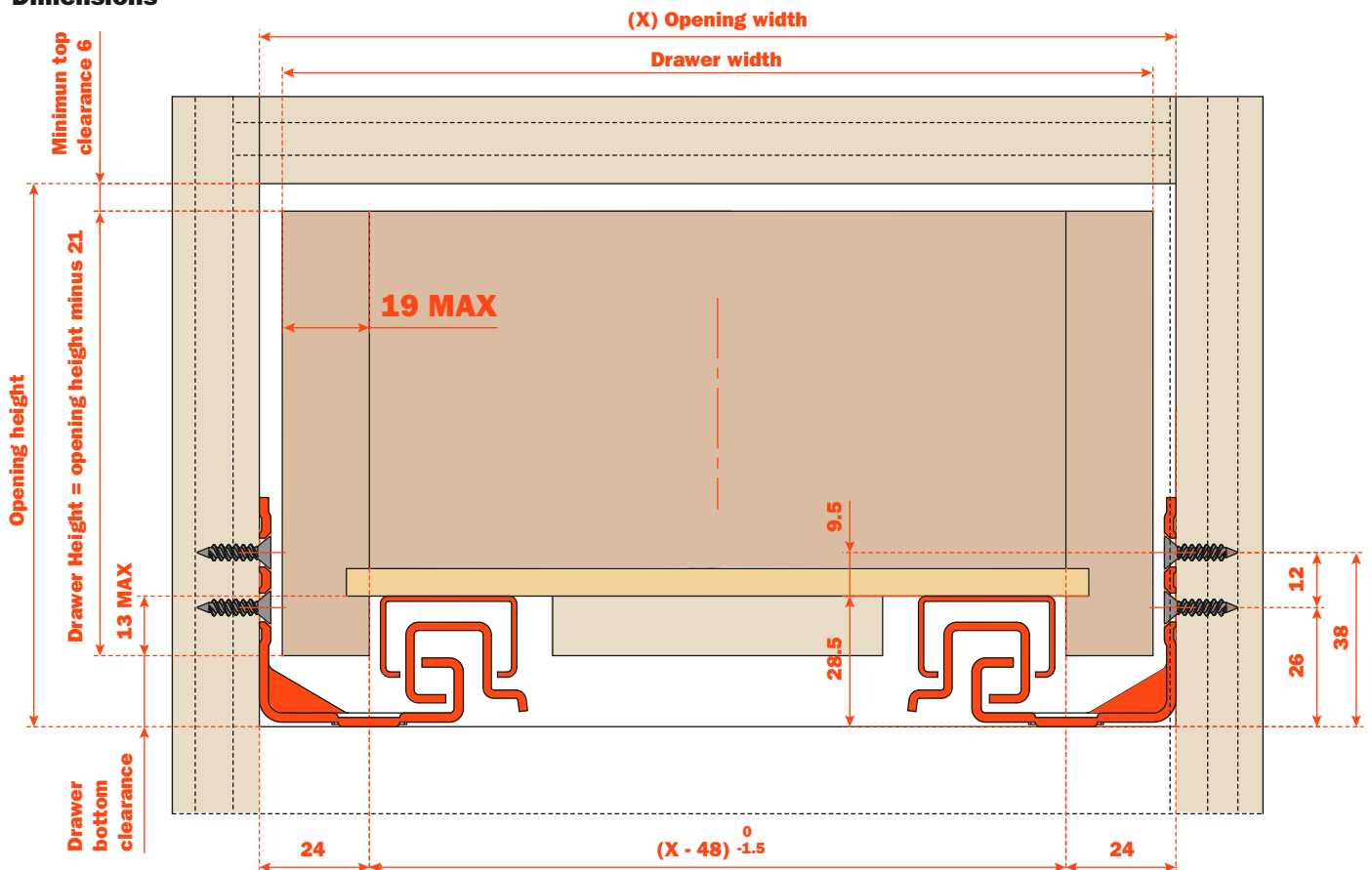

CALCULATION FORMULA FOR OUTSIDE DRAWER WIDTH

For drawer side thickness of	19 mm (3/4")	18 mm (45/64")	17 mm (43/64")	16 mm (5/8")	
Deduct from inside cabinet width	10 mm (3/8")	12 mm (7/16")	14 mm (9/16")	16 mm (5/8")	

Example: For a 15" inside cabinet width and a 3/4" thick drawer, subtract 3/8" from the inside width of 15" = 14-5/8" drawer width.

Note: Drawer side material thickness may vary. Make sure you take precise measurements when calculating outside drawer width using the table above. Inside drawer width must equal opening width minus 48 mm (1-57/64") for Progressa+ runners to align and function optimally.

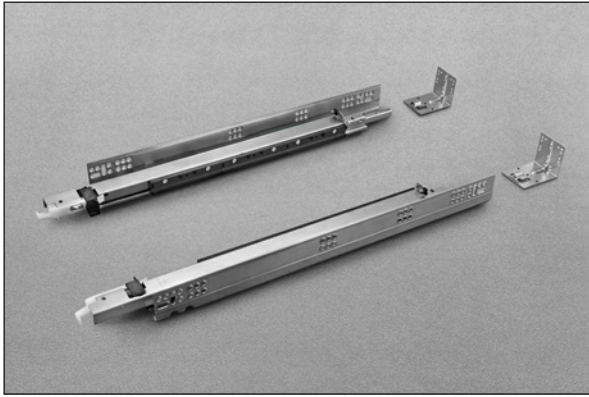

381X - 457X - 533X

Blocked out face frame cabinets or frameless

The socket can be used for the correct alignment of the runners before fixing to the cabinet side. See page 8.

AFCGX3B
(right and left)



AFCGX43B
(right and left)

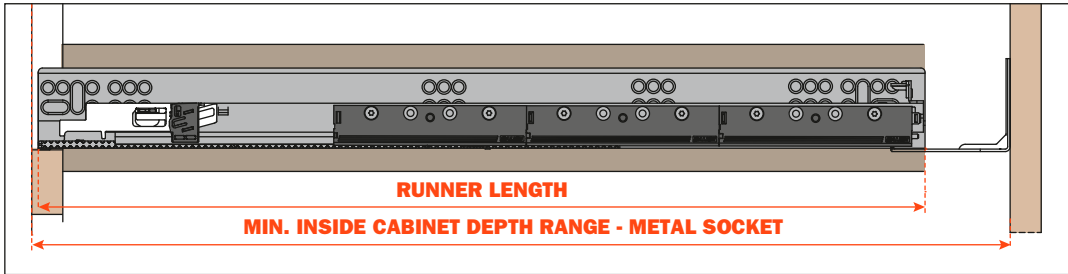

AGSK7C5B

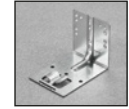

AGSK7R5B

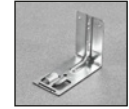

Use of rear sockets for any load above 75 Lbs is not recommended

PART NUMBER	DRAWER LENGTH (LC)	RUNNER LENGTH (LN)	MINIMUM INSIDE CABINET DEPTH	MINIMUM INSIDE CABINET DEPTH METAL SOCKET	MAXIMUM INSIDE CABINET DEPTH METAL SOCKET
G7U9P381XXF6	381 mm (15")	392 mm	401 mm	404 mm	447 mm
G7U9P457XXF6	457 mm (18")	468 mm	477 mm	480 mm	523 mm
G7U9P533XXF6	533 mm (21")	544 mm	553 mm	556 mm	599 mm



457C - 533C - 610C - 686C - 762C

Blocked out face frame cabinets or frameless. See page 9.

AFCGX3B
(right and left)



AFCGX43B
(right and left)

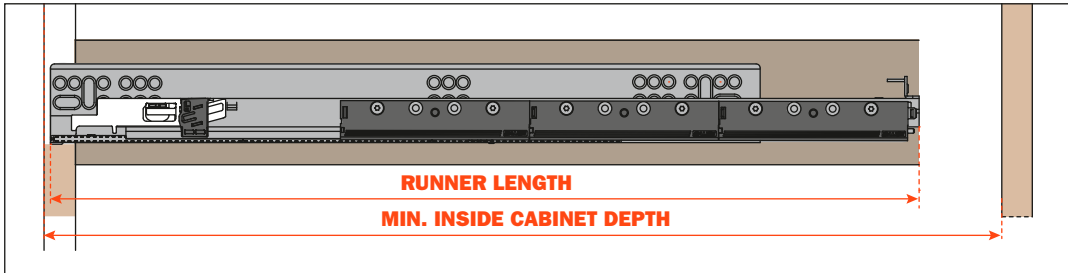

PART NUMBER	DRAWER LENGTH (LC)	RUNNER LENGTH (LN)	MINIMUM INSIDE CABINET DEPTH
G7U9P457CXF6	457 mm (18")	468 mm	477 mm
G7U9P533CXF6	533 mm (21")	544 mm	553 mm
G7U9P610CXF2	610 mm (24")	621 mm	630 mm
G7U9P686CXF2	686 mm (27")	697 mm	706 mm
G7U9P762CXF2	762 mm (30")	773 mm	782 mm



Progressa+ Shelf

Technical information

For Progressa+ Shelf slides

Plan view - Full-extension

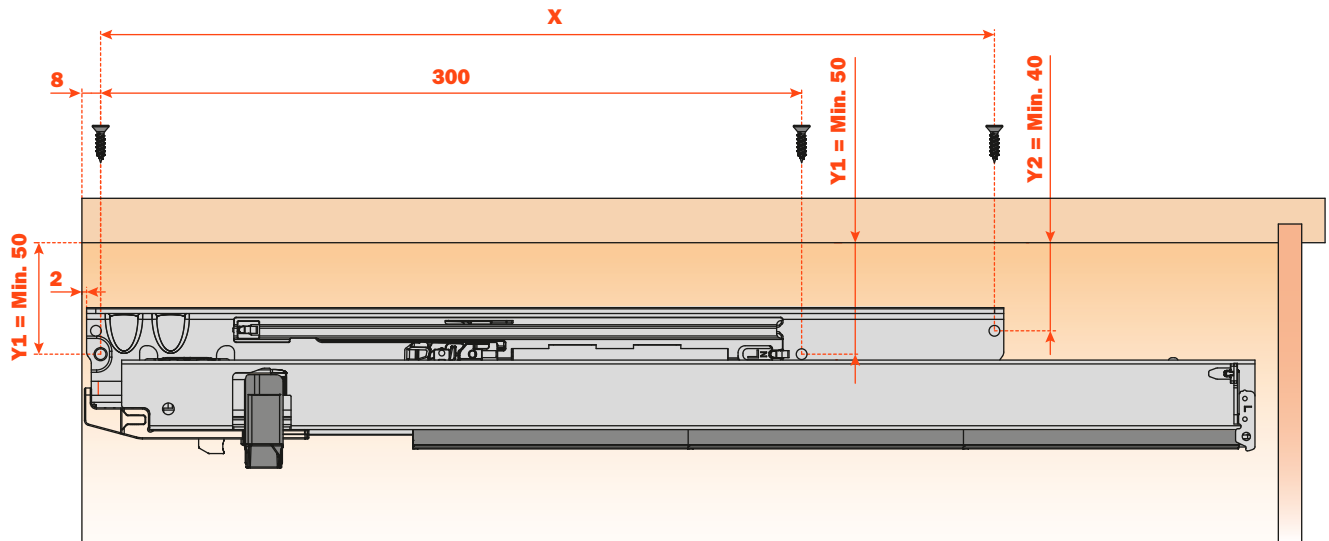

RUNNER LENGTH (LN)	X
350 mm	305 mm
400 mm	305 mm
450 mm	320 mm
500 mm	382.5 mm

Progressa+ Shelf slides when using AFGXX3B locking device

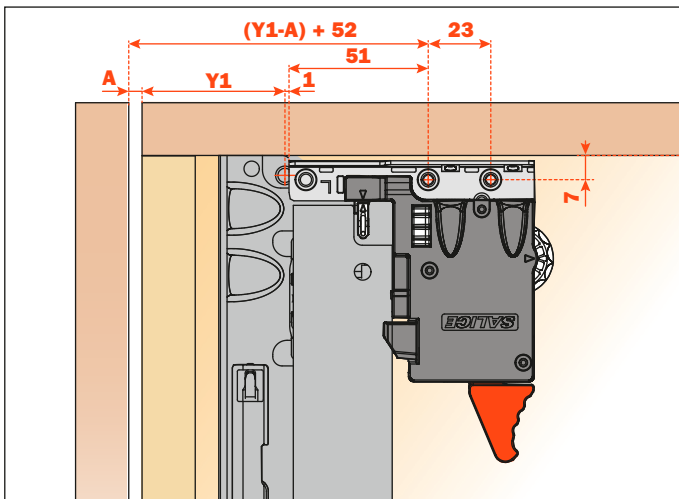

Height adjustments +2.5 mm
 Depth adjustments +/- 3 mm
 Side adjustments +/- 1.5 mm

Progressa+ Shelf slides when using AFCEX56B locking device

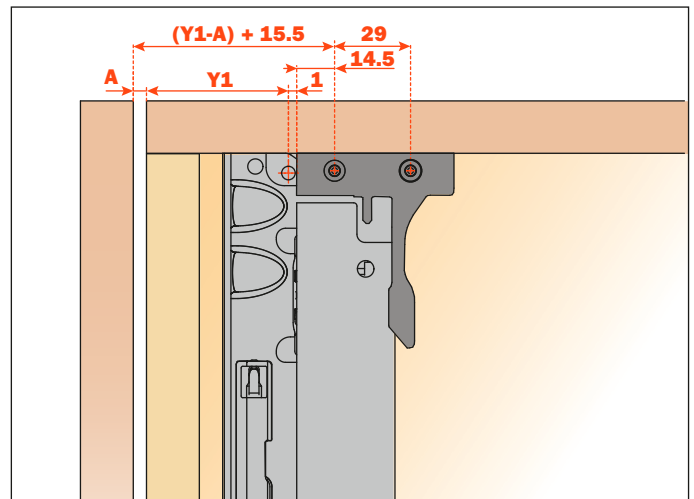

Height adjustments +2.5 mm

Technical information - Rear hook

For Progressa+ Shelf slides

Assembly on the pull-out shelf with a 12 mm minimum thickness

Rear hook bracket

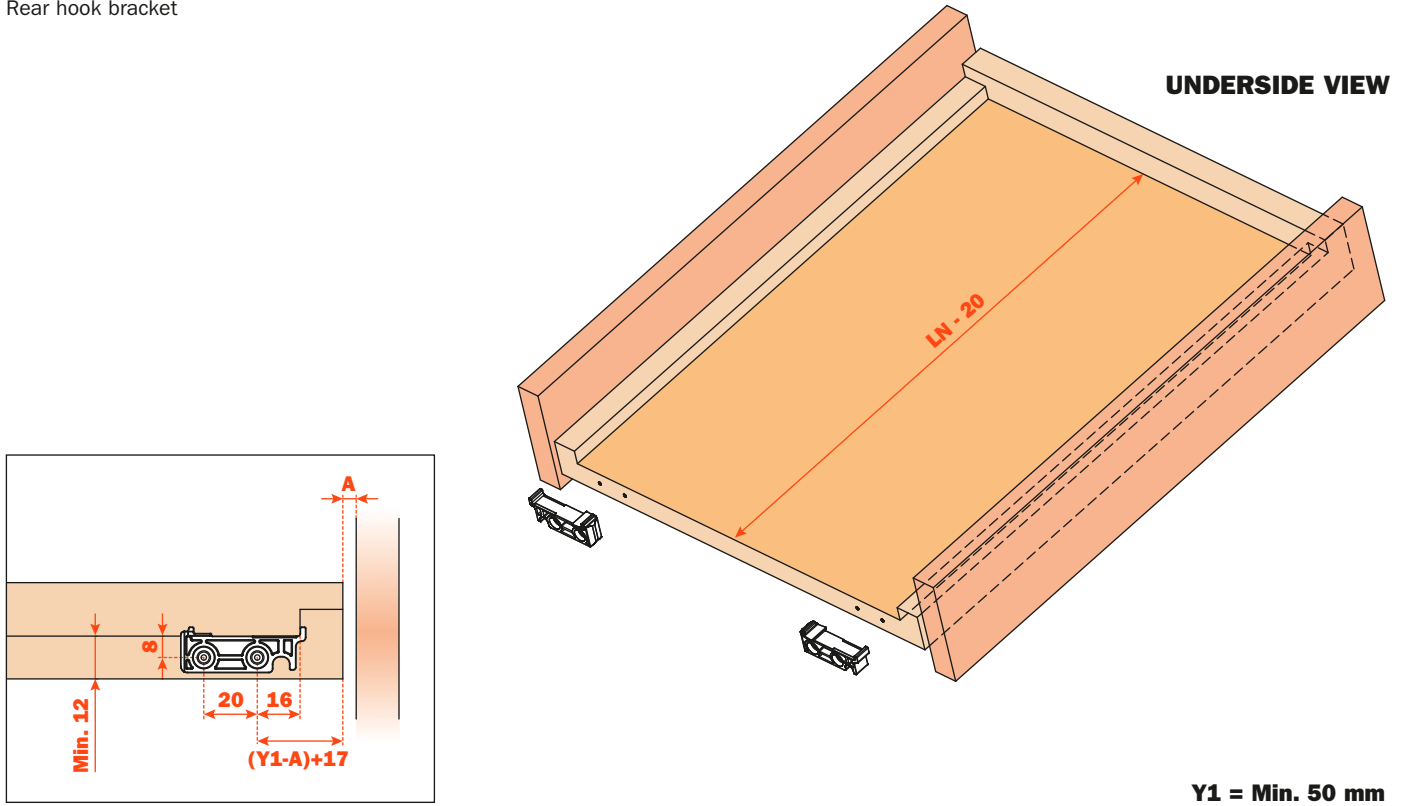

Assembly on the pull-out shelf with a 16 mm minimum thickness

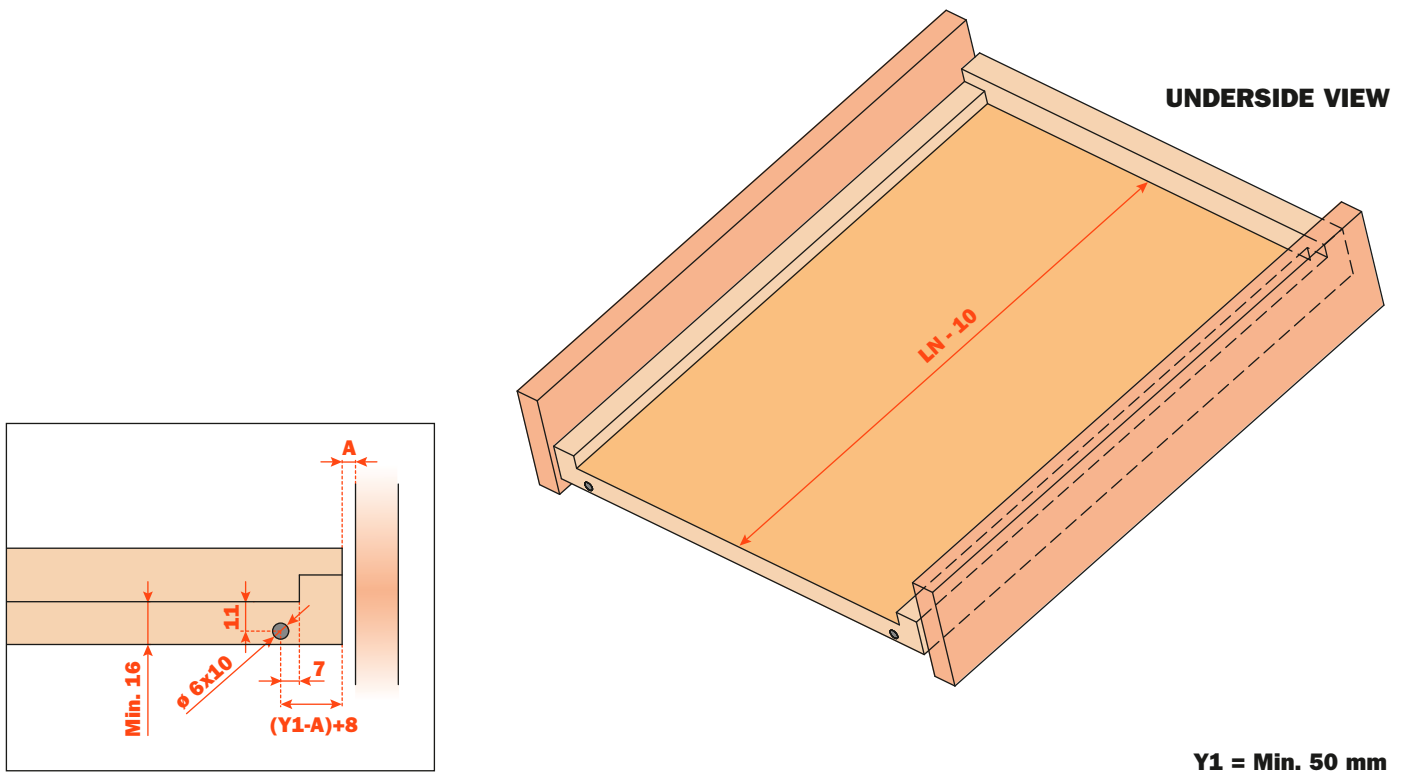

Progressa+ - Concealed undermount Shelf runner - Full-extension Shelf Smove



Full-extension runner attached to the shelf by clips.

Smove: soft closing mechanism, fully integrated into the drawer runner.

Product features

- 170 Lbs Static load capacity
- Full extension with a synchronized mechanism
- Available in 14" to 20" length
- Enhanced smooth soft closing action
- Safety system that prevents the shelves from turning over
- Tool free height adjustments +2.5 mm
- Tool free depth adjustments +/- 3 mm
- Tool free side adjustments +/- 1.5 mm
- Finish: bright zinc-plated
- 100% Made in Italy

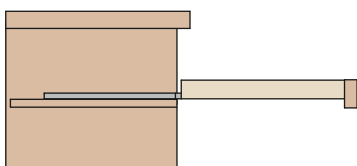

Dimensions

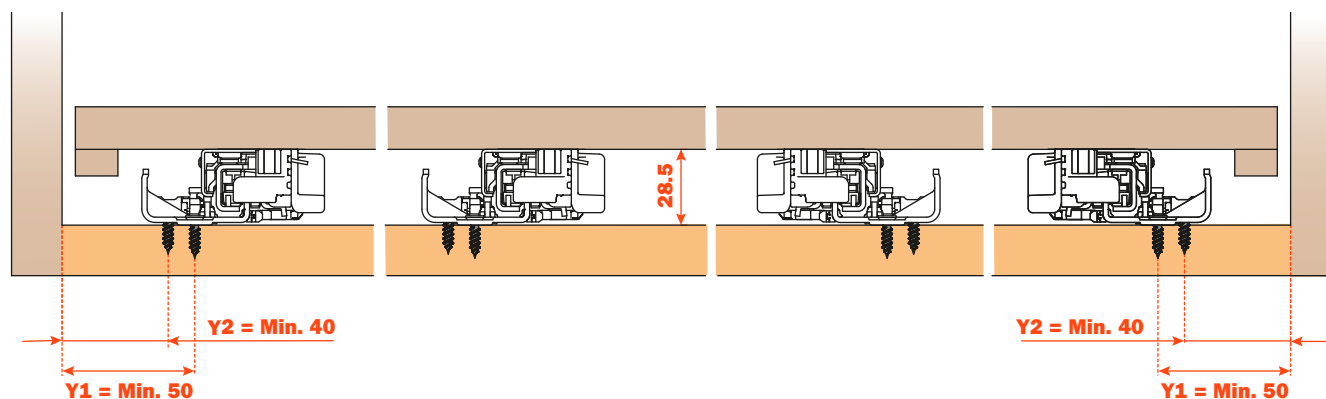
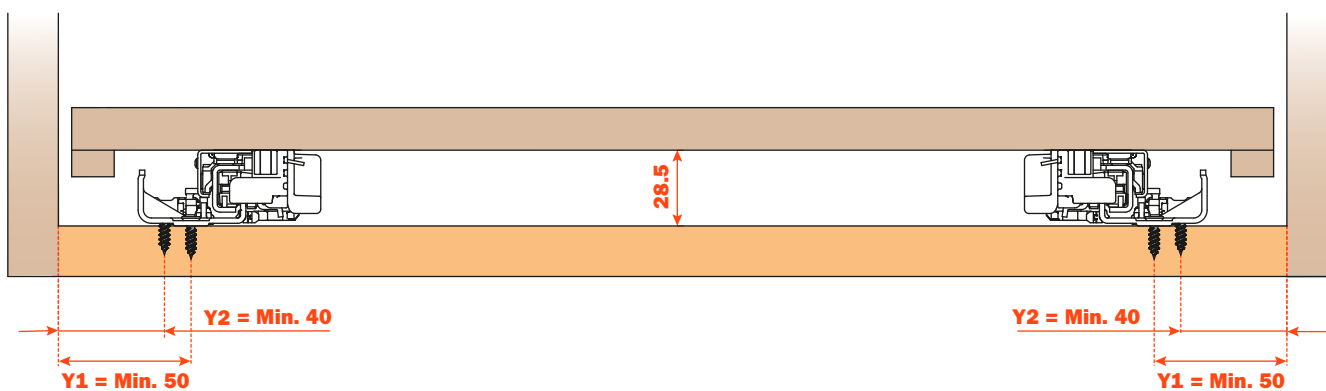

With larger and wider shelves, it is possible to increase the number of runners in order to improve the load capacity and the stability.



Assembles on bottom, can be used in any quantities to improve action

AFCGX3B
(right and left)



AFCEX56B
(right and left)

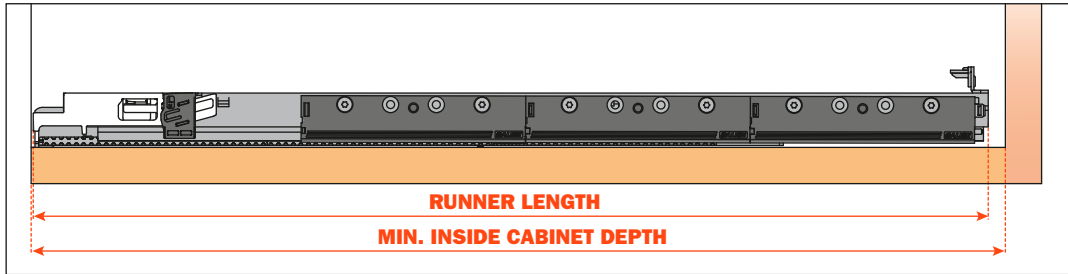

PART NUMBER	RUNNER LENGTH (LN)	MIN. CABINET DEPTH (PM)
G7E6R350XXF6	350 mm	360 mm
G7E6R400XXF6	400 mm	410 mm
G7E6R450XXF6	450 mm	460 mm
G7E6R500XXF6	500 mm	510 mm

**Progressa+ - Concealed undermount Shelf runner - Full-extension
Shelf Push to open**



Full-extension runner attached to the shelf by clips.

Push: the opening system for handle-less drawers is fully integrated in the runner. A slight pressure of the drawer front is enough for the drawer to open.

Product features

- 170 Lbs Static load capacity
- Full extension with a synchronized mechanism
- Available in 14" to 20" length
- Integrated Push opening system
- Safety system that prevents the shelves from turning over
- Tool free height adjustments +2.5 mm
- Tool free depth adjustments +/- 3 mm
- Tool free side adjustments +/- 1.5 mm
- The shelf is held in the closed position
- Finish: bright zinc-plated
- 100% Made in Italy

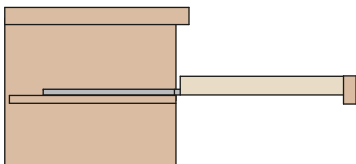

Dimensions

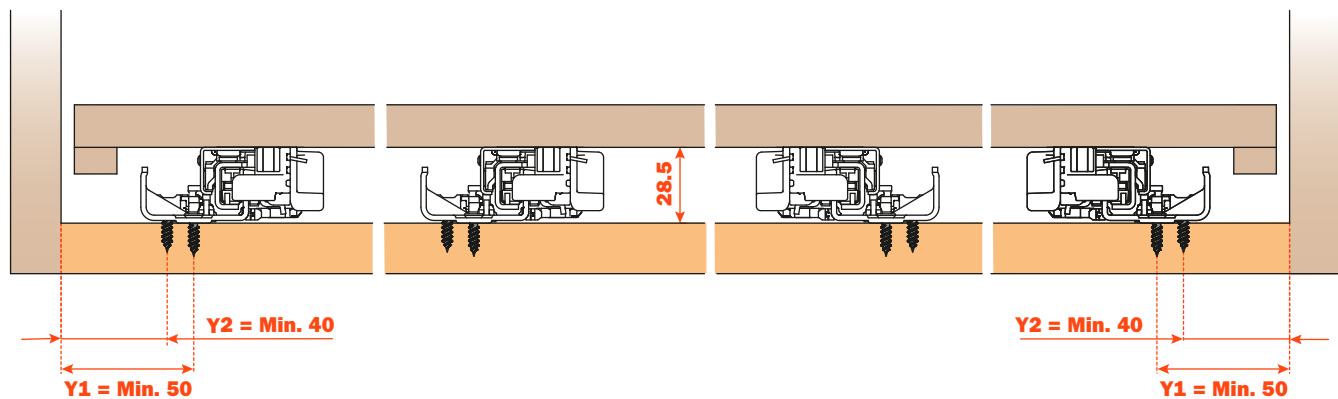
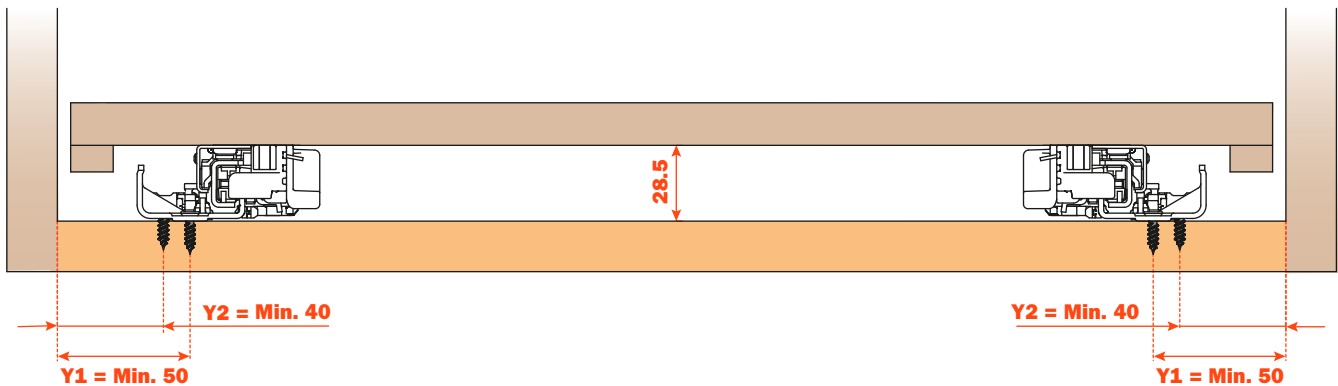

With larger and wider shelves, it is possible to increase the number of runners in order to improve the load capacity and the stability.



Assembles on bottom, can be used in any quantities to improve action

AFCGX3B
(right and left)

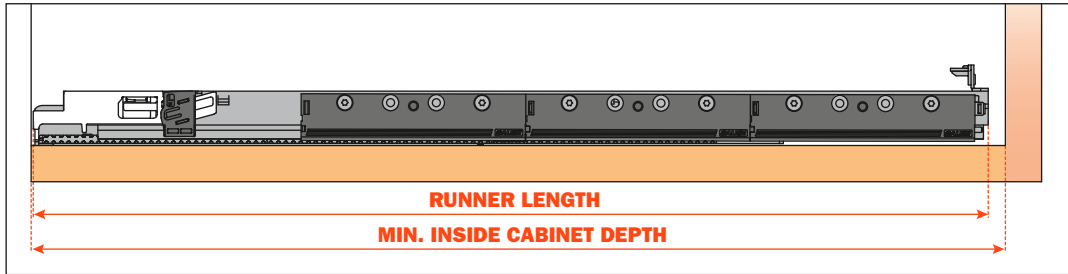

PART NUMBER	RUNNER LENGTH (LN)	MIN. CABINET DEPTH (PM)
G7E6Q350XXF6	350 mm	360 mm
G7E6Q400XXF6	400 mm	410 mm
G7E6Q450XXF6	450 mm	460 mm
G7E6Q500XXF6	500 mm	510 mm

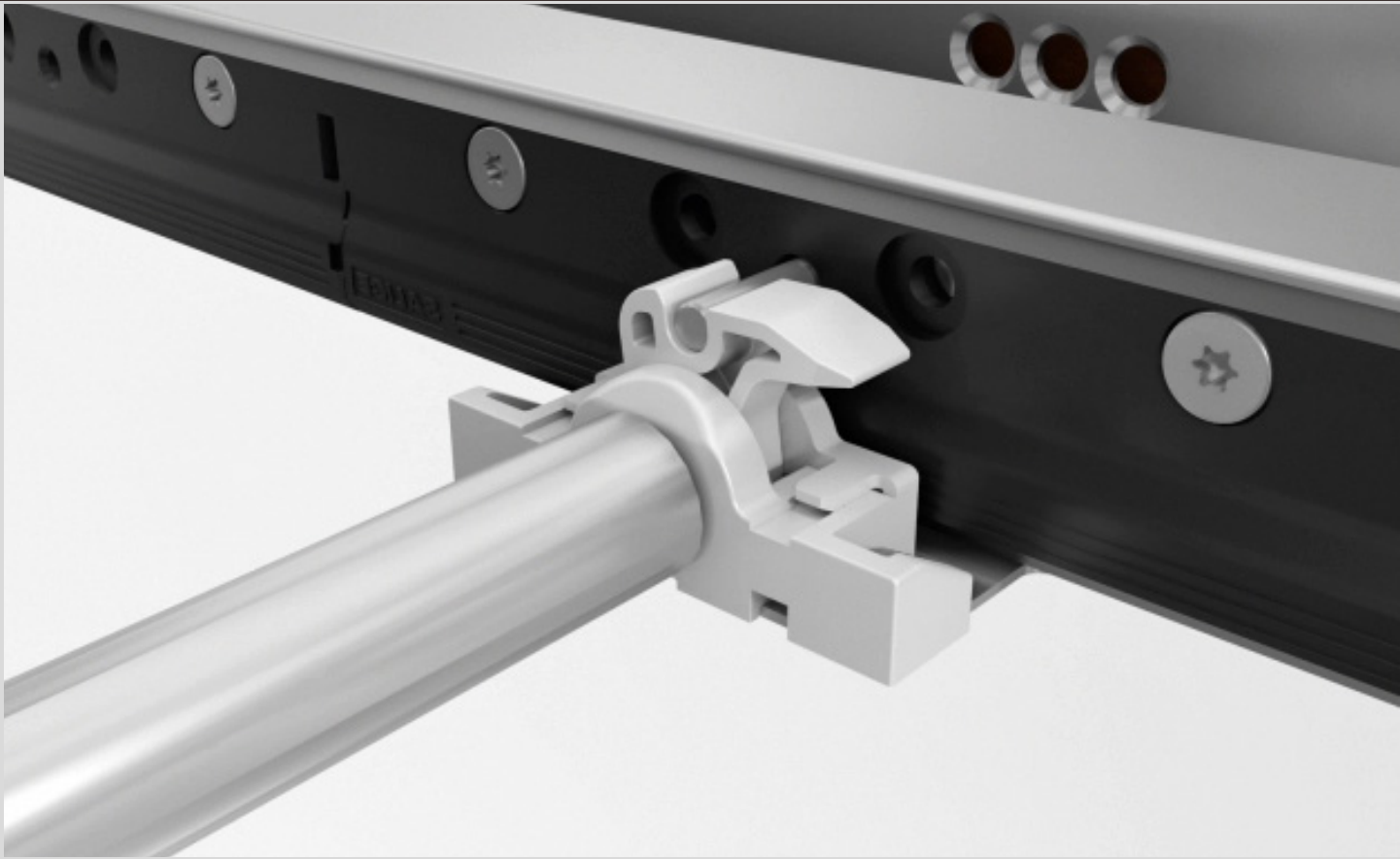

Accessories

Push Synchronizer bar

The synchronization system for Push-to-Open **Progressa+** slides has been developed to ensure that wider drawers can be opened with minimum effort, regardless of where pressure is applied. The system links the two runners, which then become a single element; applying pressure on any part of the drawer front (even at the extremities), is sufficient for the Push devices to release and consequently for the drawer to open.

The synchronization can be used with any drawer width; its functionality is at its best with drawers wider than 762 mm (30").

PRODUCT FEATURES:

- frameless or blocked out face frame applications
- smooth and progressive running action
- slide load capacity remains unchanged
- available on any **Progressa+** drawer length
- minimum opening (X) = 280 mm (11")
- maximum opening (X) = 1305 mm (51 - 3/8")
- bar length = 1150 cut to size



Technical information - Formula for cutting the bar to length

The assembly of the synchronizer requires a minimum 76.2 mm (3") groove in the rear of the drawer.

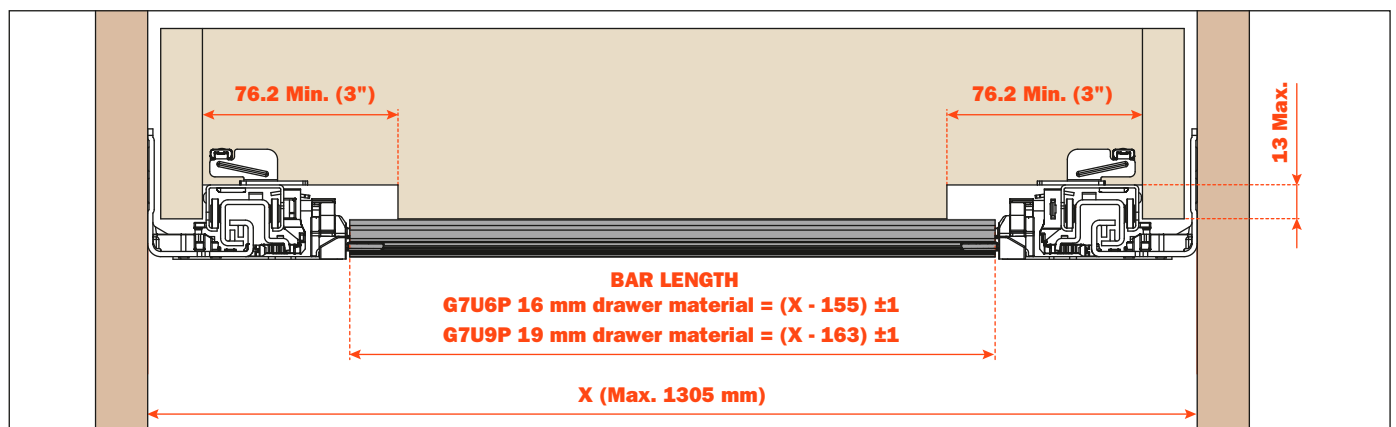

X = Internal width of the cabinet

Assembly instructions

Slide the carrier plates into position on the runners in the direction indicated by the arrows

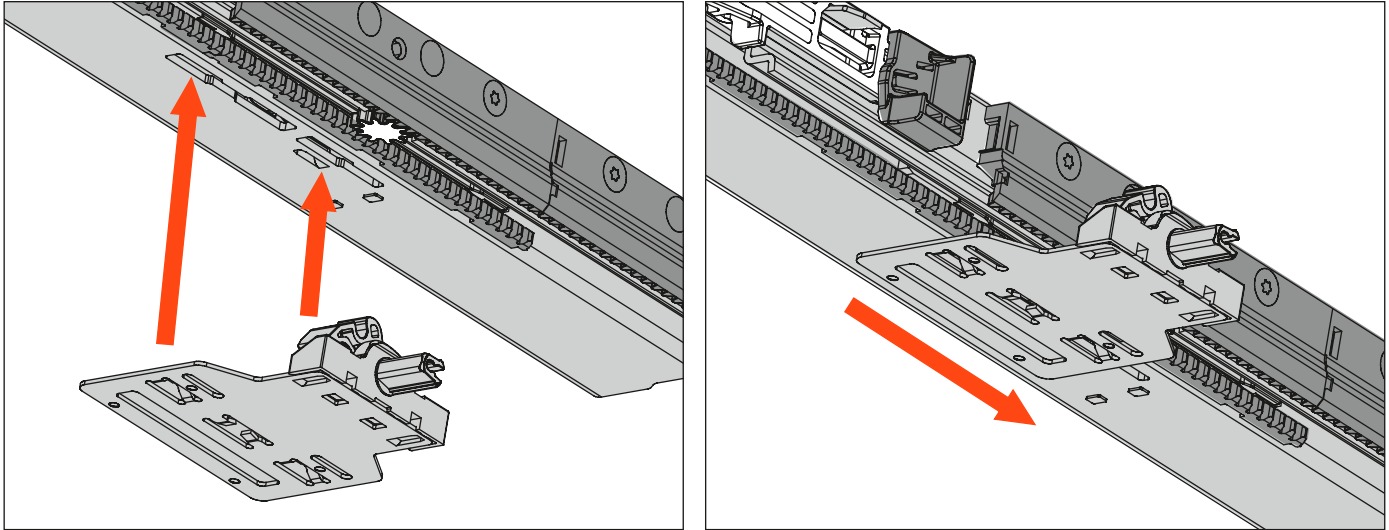

Fitting the driver pins to the runners

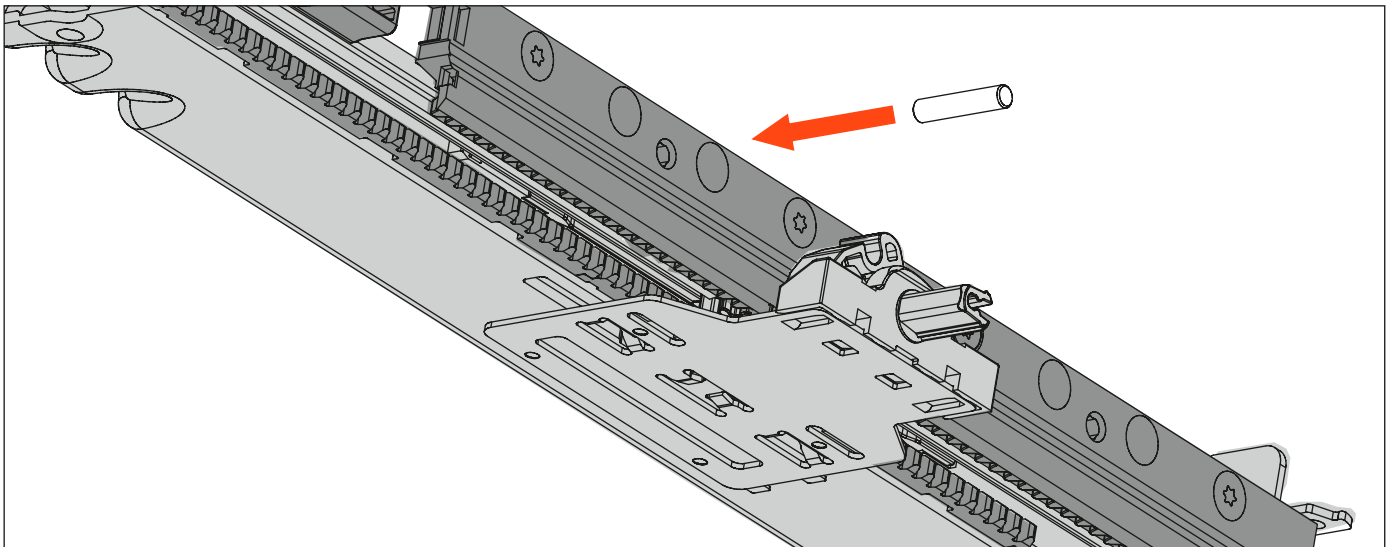

Cut the stabilizer bar to length

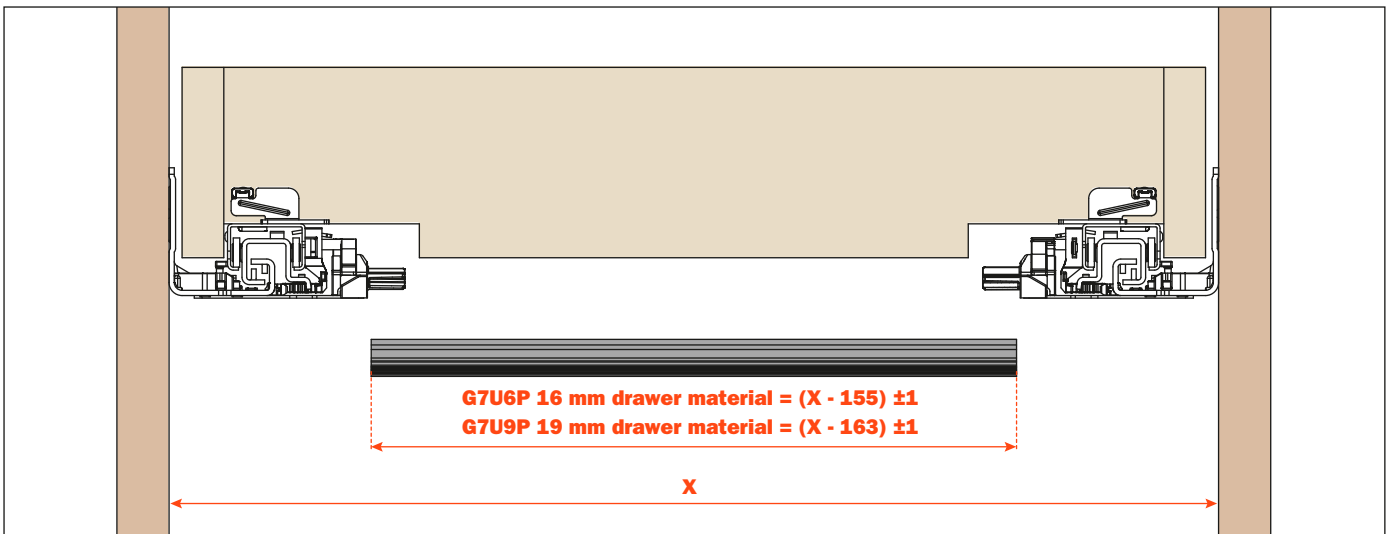

Assembly instructions

Fix the bar to the plates and insert the drawer

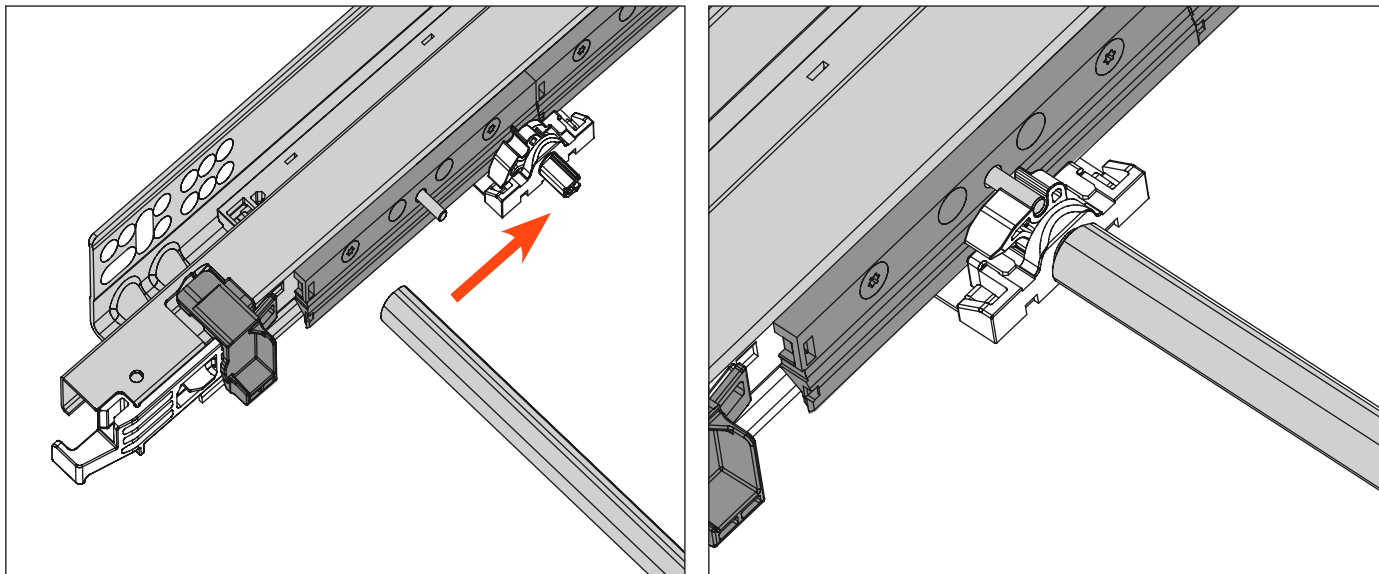

Applying pressure on any part of the drawer front is sufficient for the drawer to open

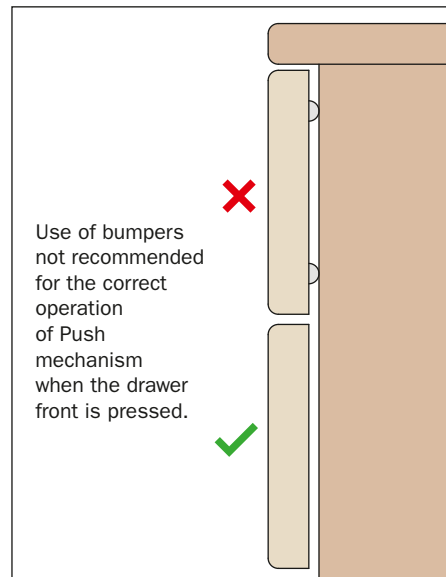

Packaging

SYNCHRONIZER - SINGLE KIT PACKAGING

APKF7X51150

PACKAGING

1 box = 20 single kits

1 KIT CONTAINS:

- 1 synchronizer bar
- 2 driver pins
- 1 right carrier plate and 1 left carrier plate



Metal sockets - For all Progressa and Progressa+ slides

Standard metal socket

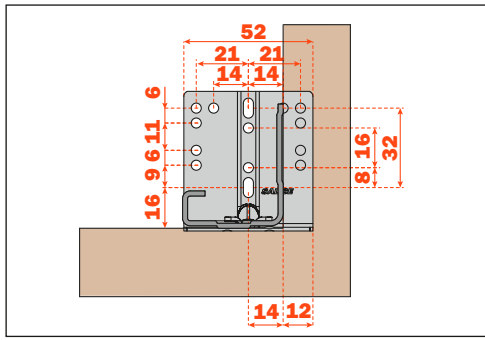
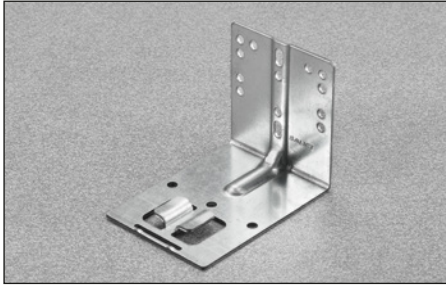

AGSK7C5B

PACKAGING: 1 box = 100 pcs

- For Progressa full extension slides
- Lateral self-alignment feature
- One piece stamped metal, zinc-coated
- Non-handed
- Use a minimum of 4 screws per socket

Narrow metal socket

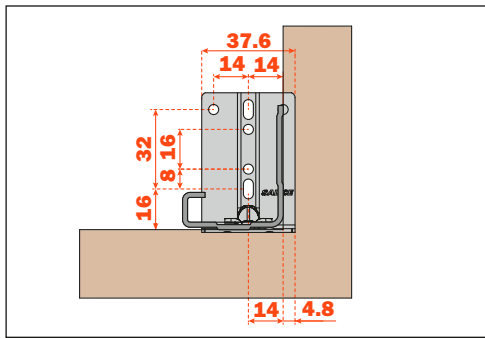
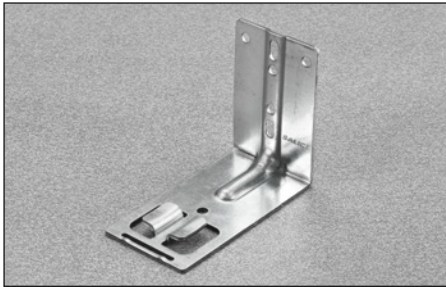

AGSK7R5B

PACKAGING: 1 box = 100 pcs

- For Progressa full extension slides
- Lateral self-alignment feature
- One piece stamped metal, zinc-coated
- Non-handed
- Use a minimum of 4 screws per socket

Plastic sockets - For Progressa slides

Plug in socket

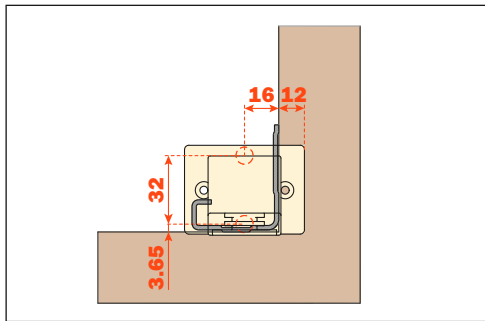
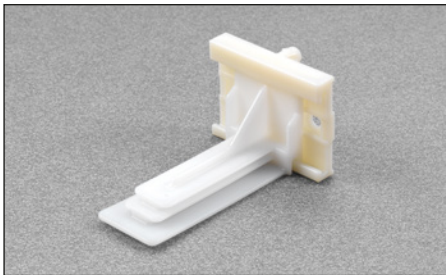

ASOG5G7AJYD

PACKAGING: 1 box = 100 pcs

- For Progressa full extension slides
- Lateral self-alignment feature
- Two pieces synthetic, natural color ABS
- Non-handed
- 8 mm (5/16") dowels
- Screw-on back

Screw on socket

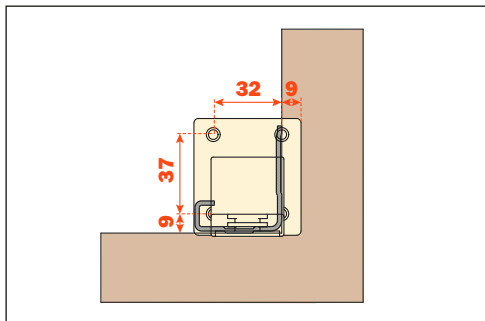

ASOG5G7AJND

PACKAGING: 1 box = 100 pcs

- For Progressa full extension slides
- Lateral self-alignment feature
- Two pieces synthetic, natural color ABS
- Non-handed
- Screw-on back

Screw on socket for 9" slides

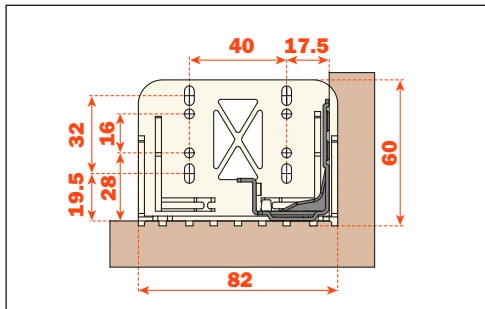
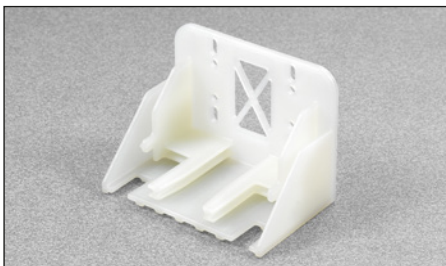

ASO755NAND9

PACKAGING: 1 box = 100 pcs

- For 9" slides
- Minimum inside cabinet depth: 290 mm
- One piece synthetic natural color
- Lateral self-alignment feature
- Non-handed
- Use at least two fixing screws

Drilling templates for drawers - For all Progressa, Progressa+ and Progressa+ Shelf slides

Pre-drilling for the clips reduces the possibility of splitting the wood, thus assuring the correct and level installation of the clips.
The correct and level mounting assures a smooth assembly and operation of the drawer slide.

ASGD704U3XA

PACKAGING: 1 box = 1 pc.

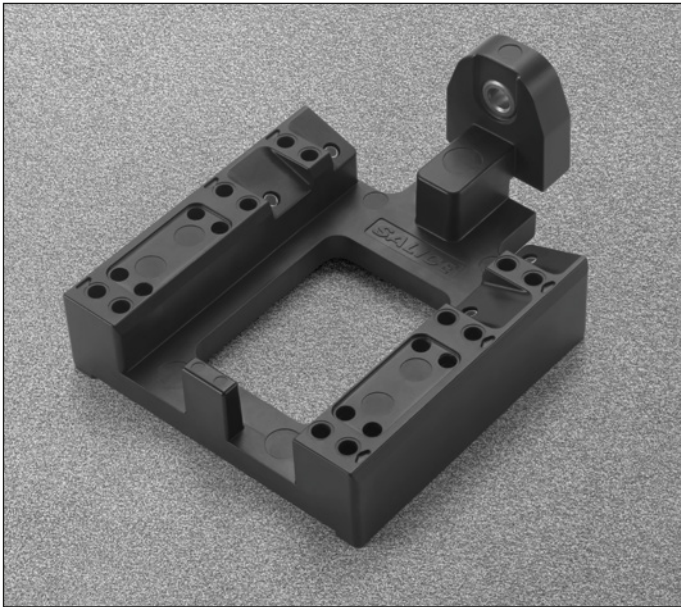

AFCGXX3B
(right and left)



AFCGX43B
(right and left)



AFCGX43B
(right and left)



Back drilling for hook

Pre-bore for rear hook for proper alignment and depth (min. depth = 10 mm or 13/32")

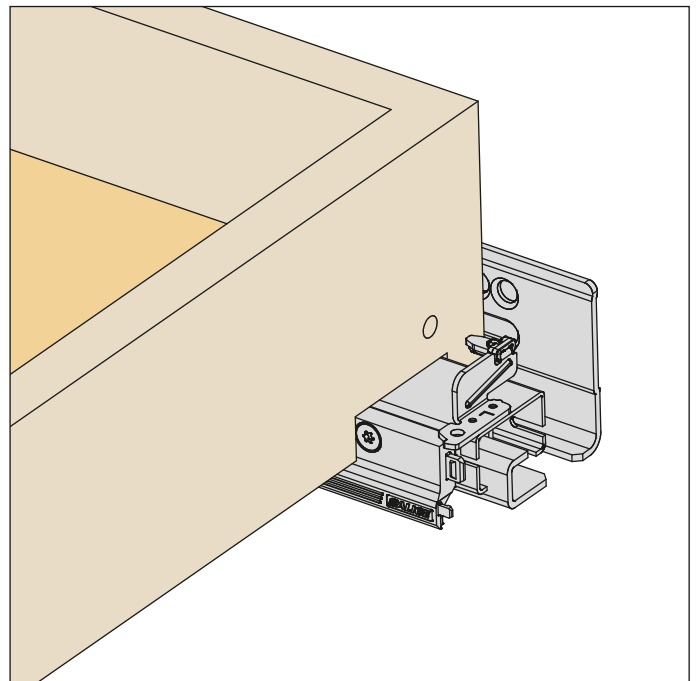
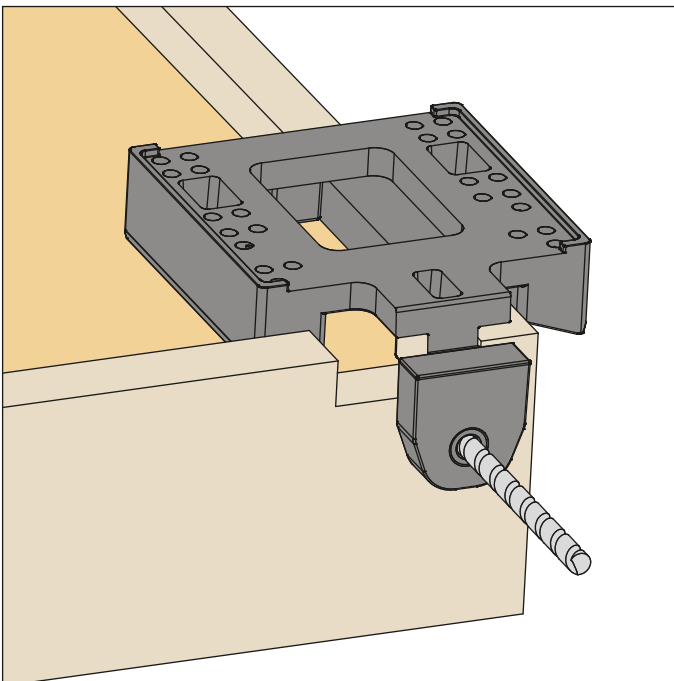

Use a \varnothing 6 mm (1/4") drill bit

Angled drilling for clips, fixing on the sub-front

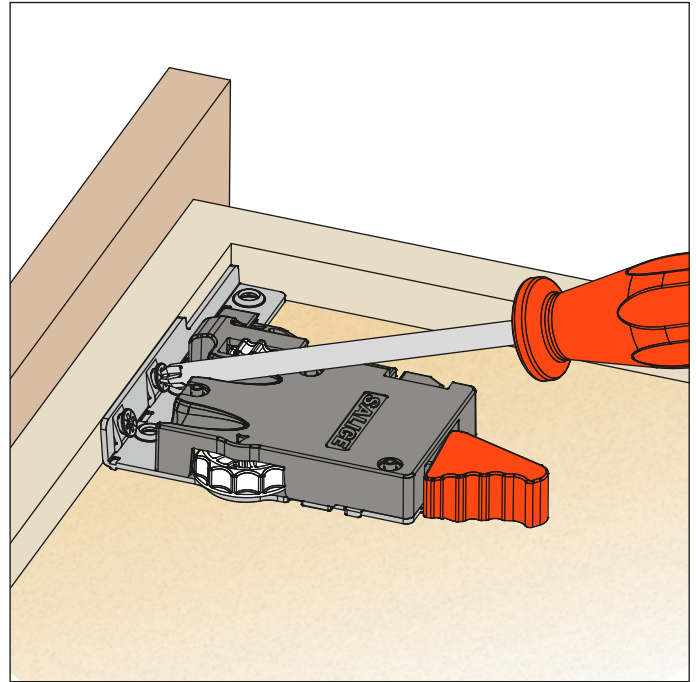
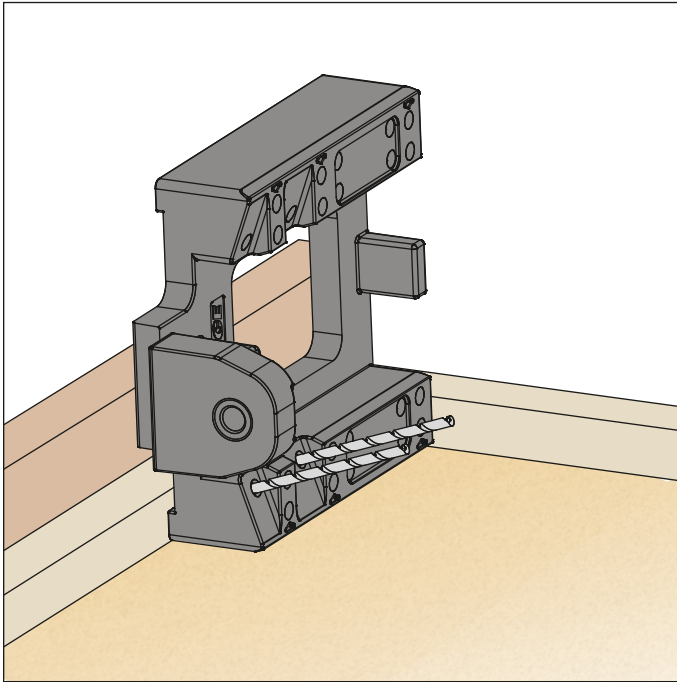

Use a \varnothing 2.5 mm (3/32") drill bit

Vertical drilling for clips, fixing on the bottom

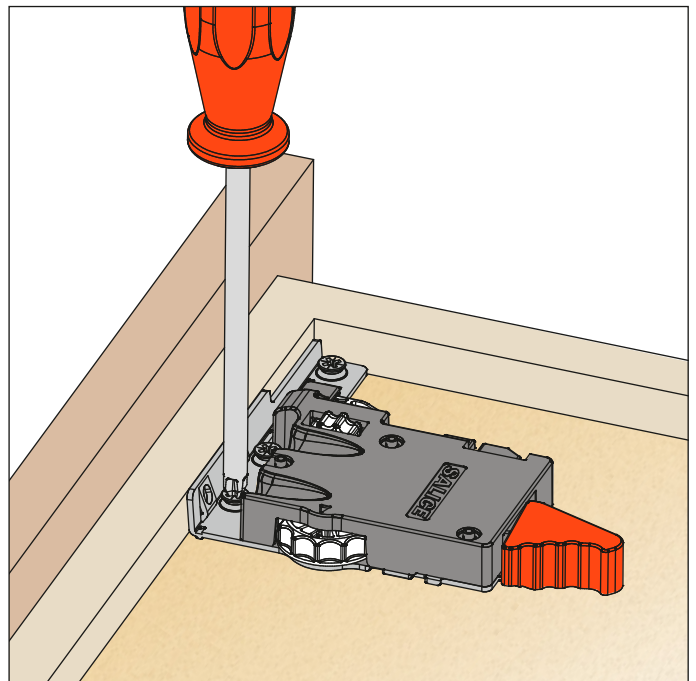
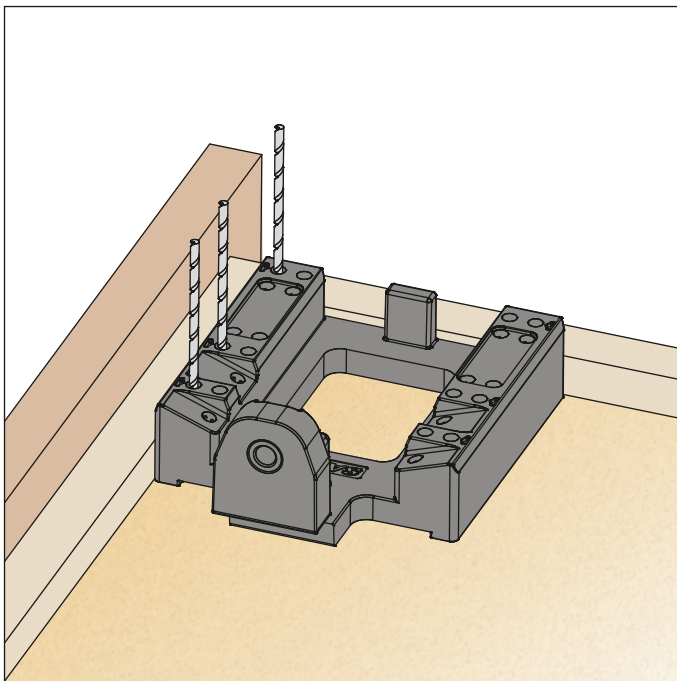

Use a \varnothing 2.5 mm (3/32") drill bit

Drilling templates for drawers

Fixing directly on drawer bottom

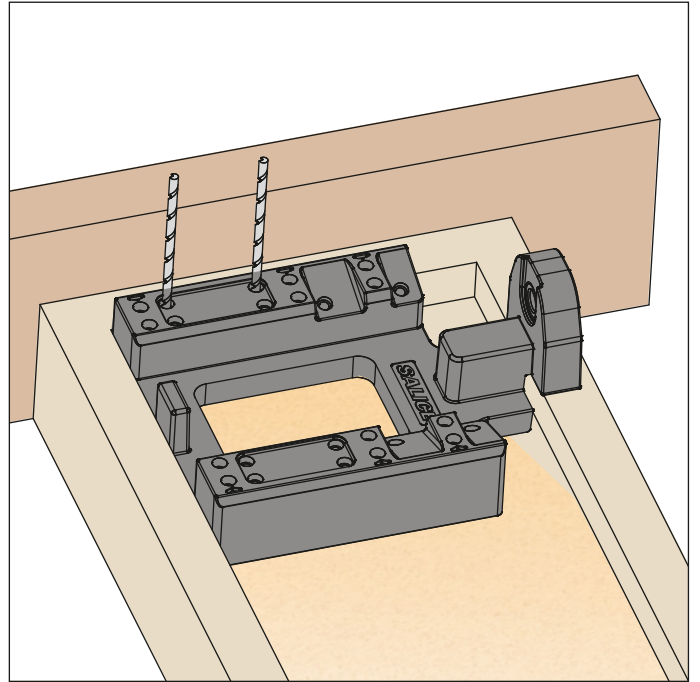
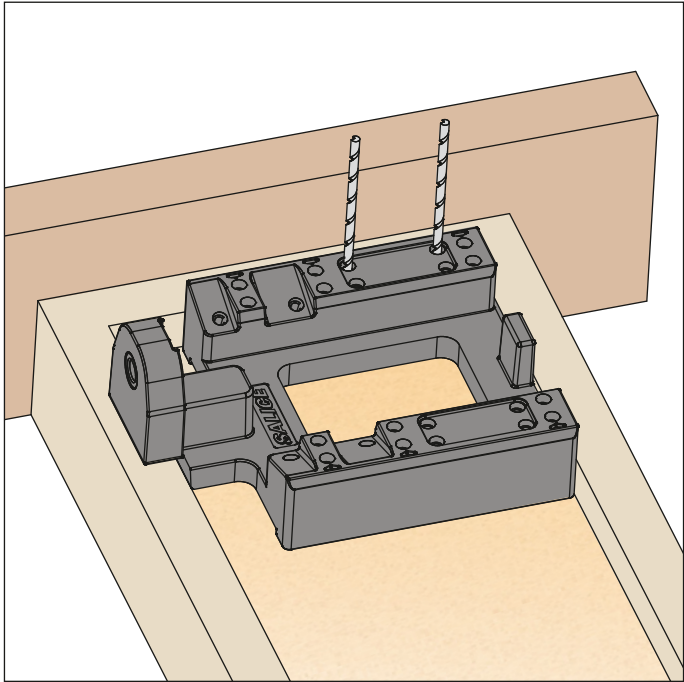

Use a \varnothing 2.5 mm (3/32") drill bit

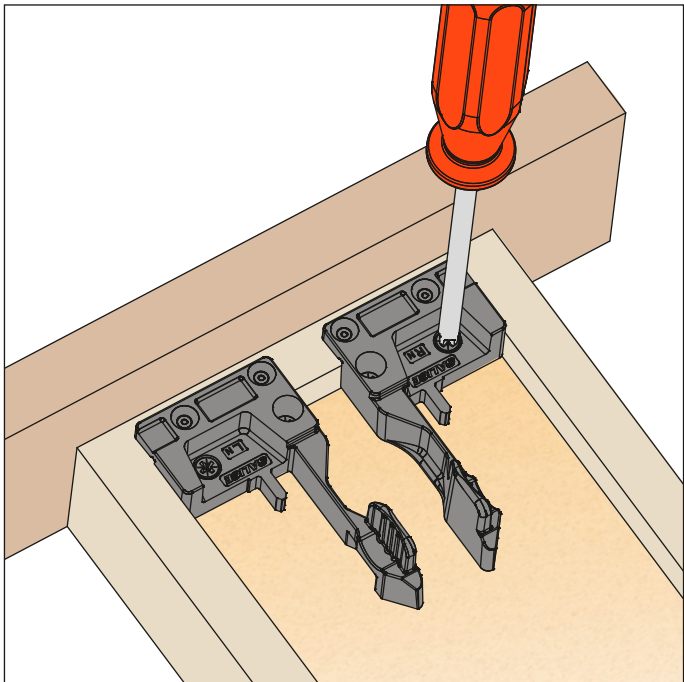

Drilling templates for drawers - For all Progressa, Progressa+ and Progressa+ Shelf slides

Pre-drilling for the clips reduces the possibility of splitting the wood, thus assuring the correct and level installation of the clips.
The correct and level mounting assures a smooth assembly and operation of the drawer slide.

ASGD504U6XA

PACKAGING: 1 box = 1 pc.

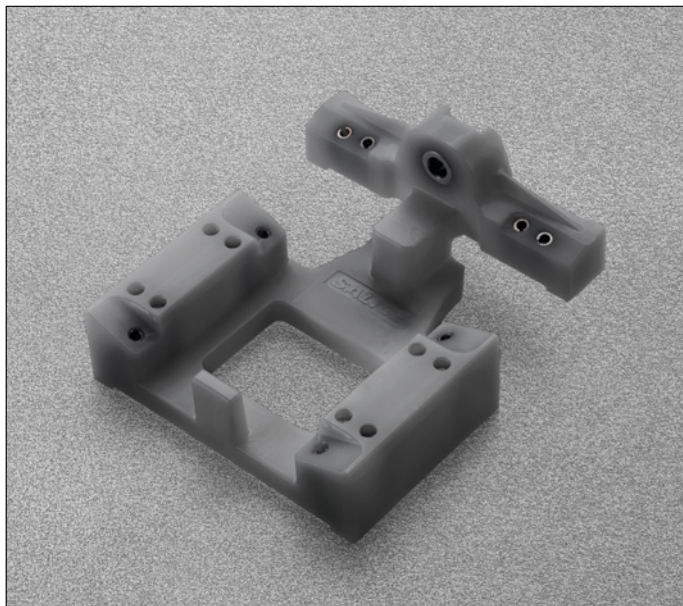

AFCEX56B (right and left)



Back drilling for hook

Pre-bore for rear hook for proper alignment and depth (min. depth = 10 mm or 13/32")

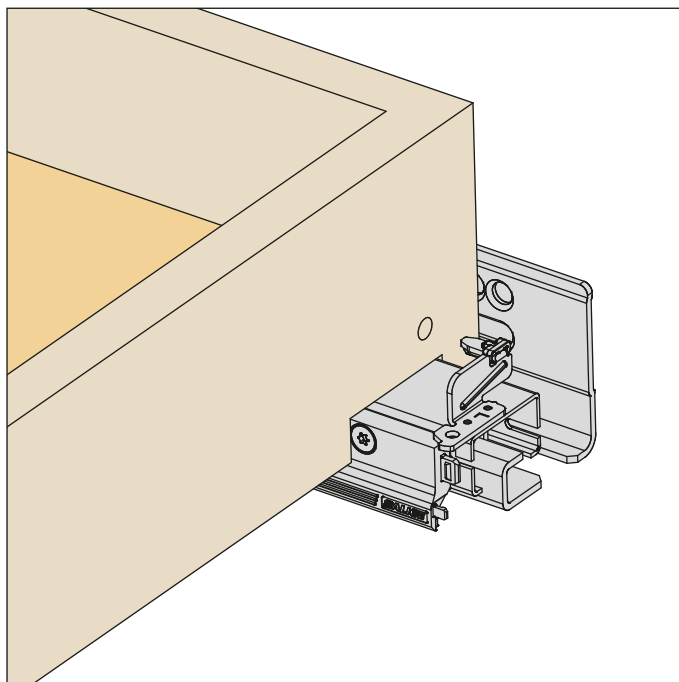
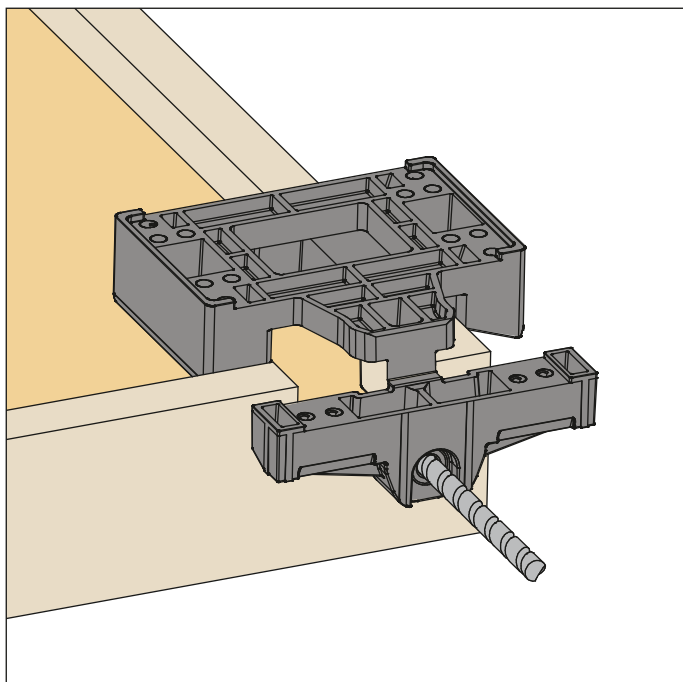

Use a \varnothing 6 mm (1/4") drill bit

Drilling templates for drawers

Fixing the clip on the drawer member

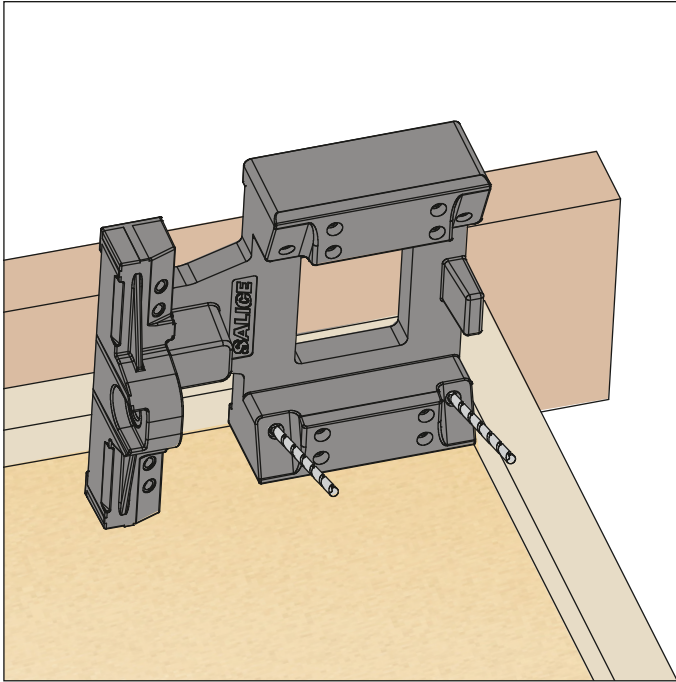

Use a \varnothing 2.5 mm (3/32") drill bit

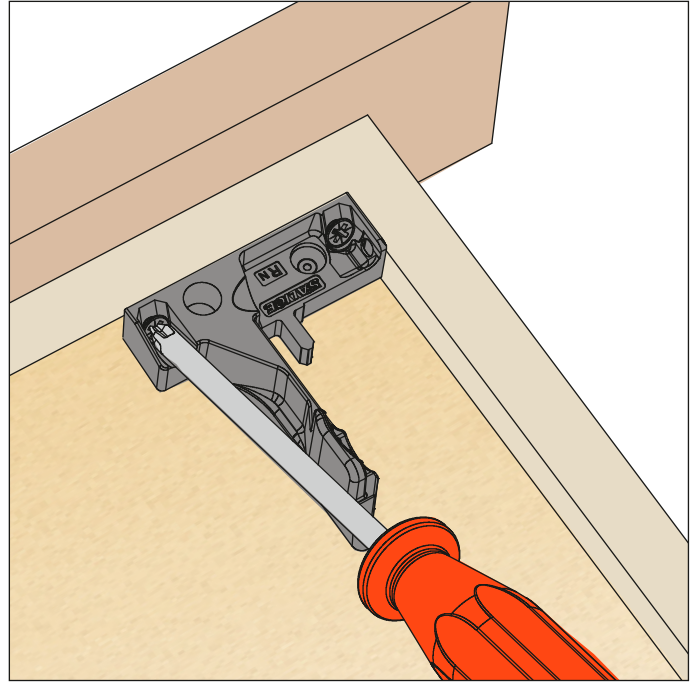

The use of 6 x 5/8" screws is recommended for a correct operation of the clips

Vertical drilling for clips, fixing on the bottom

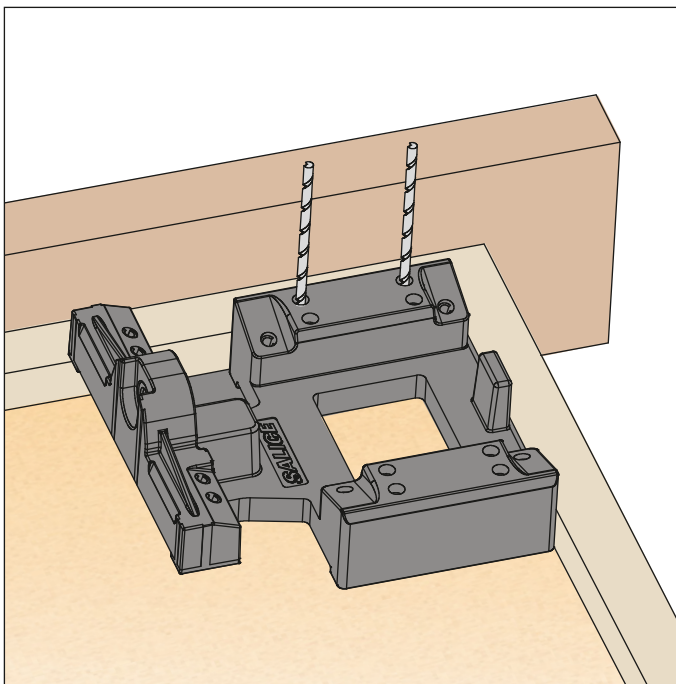

Use a \varnothing 2.5 mm (3/32") drill bit

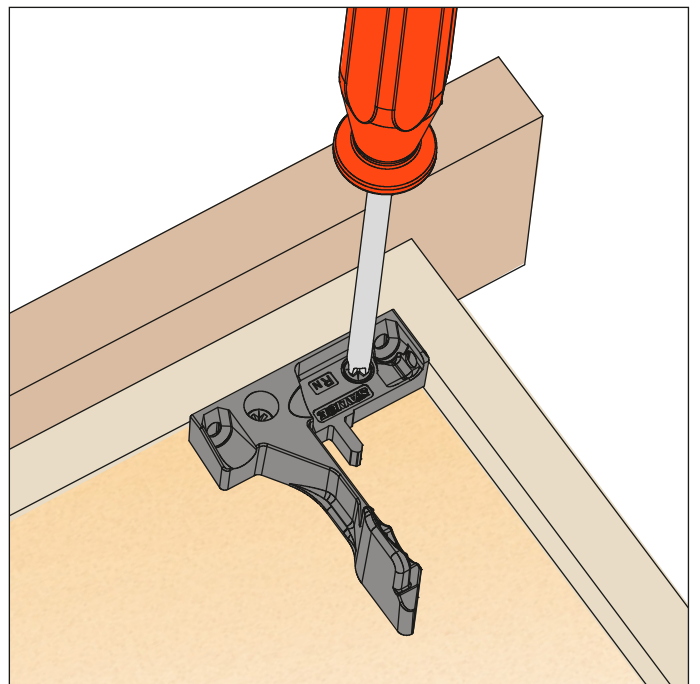

Optional lateral fixing

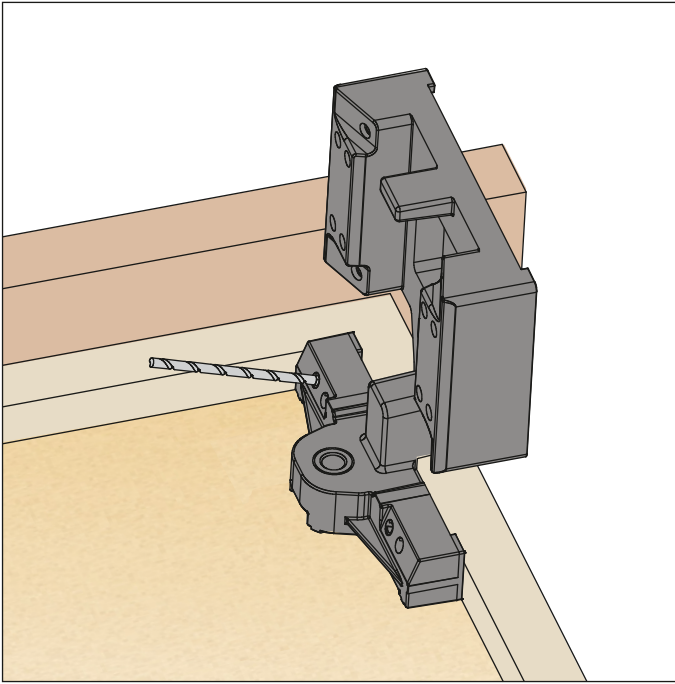

Use a \varnothing 2.5 mm (3/32") drill bit

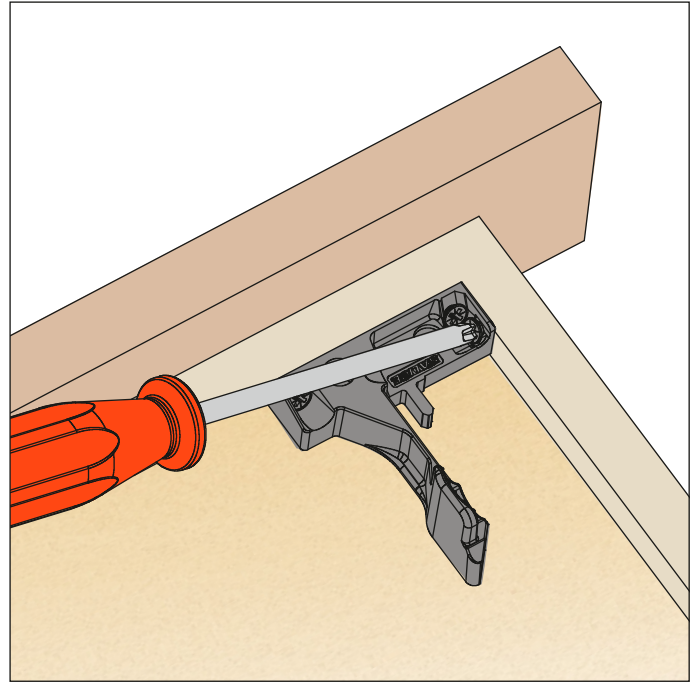

The use of 6 x 5/8" screws is recommended for a correct operation of the clips

Accessories - For all Progressa and Progressa+ slides

Tilt adjustment lever

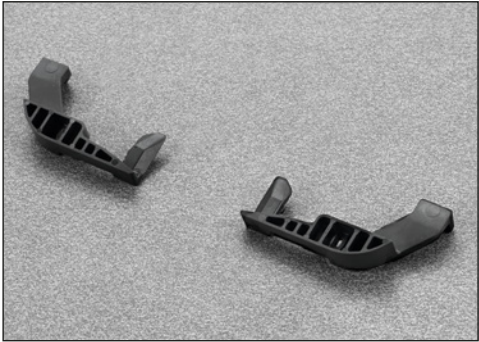

AGLRXX3F

PACKAGING: 1 box = 12 pcs right / 12 pcs left

Technical information, see page 27.

Side spacer

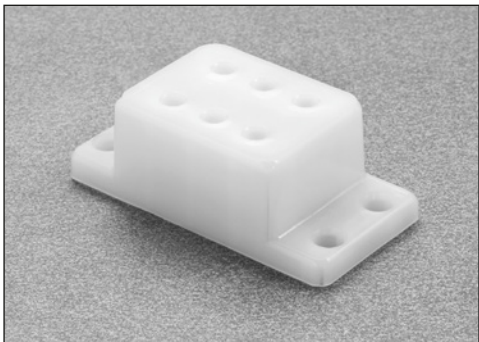

ASPACERFUT

PACKAGING: 1 box = 100 pcs

For spacing out Progressa runners for clearance on interior roll-outs.

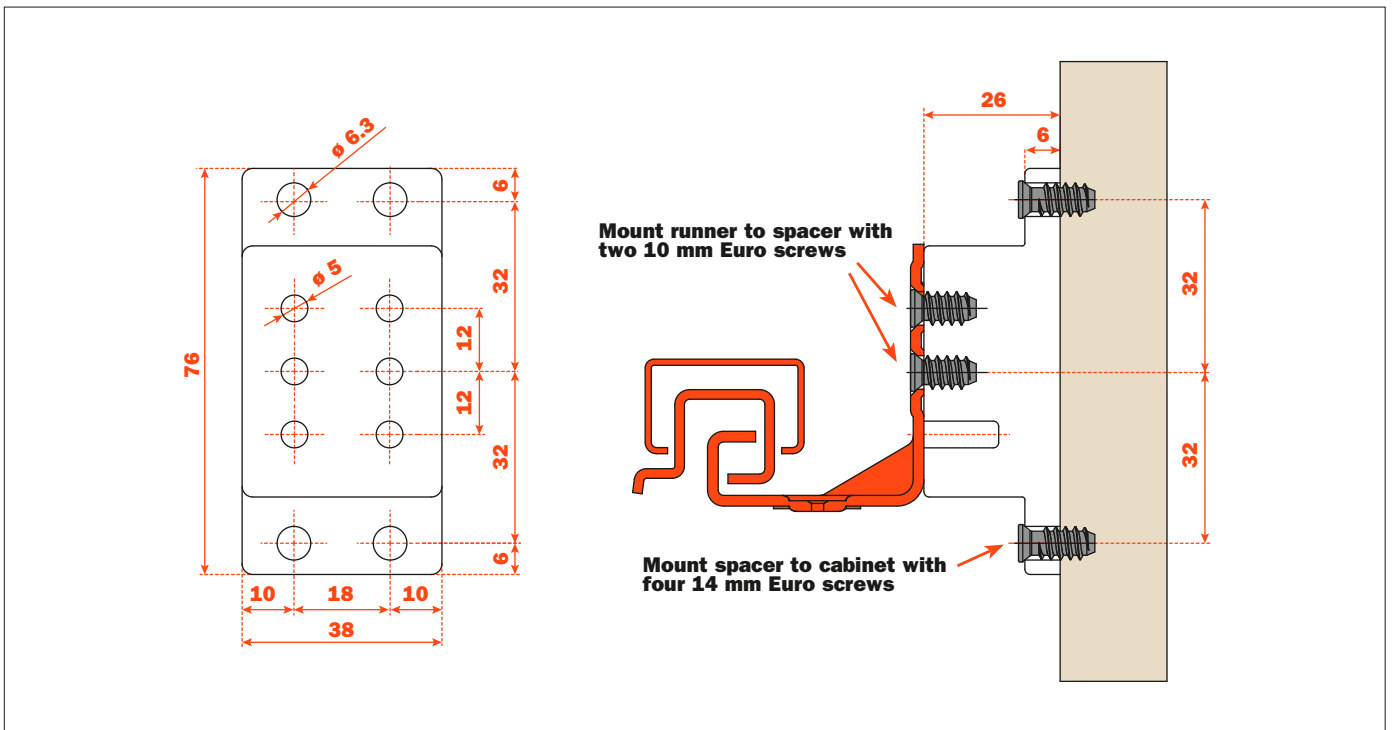

Spacer for 1/2" drawer sub-fronts

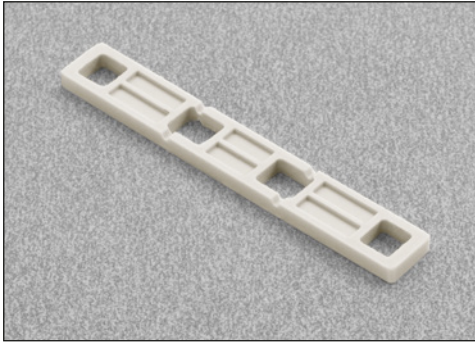

AFSFXXB

For drawer sides with sub-fronts between 12 and 13 mm (1/2"), we recommend the use of the build-up spacer.

PACKAGING: 1 box = 100 pcs

When drawer sub-fronts are too thin, they may not engage properly with the front locking devices on the drawer slides, leading to compromised functionality.

The Front Locking Device Spacer for Thin Drawer Sub-Fronts is a precision-engineered solution for Progressa slides, designed specifically to accommodate sub-front thicknesses of 12 mm (15/32") and 13 mm (1/2").

This spacer can only be used with the AFCGX3B or the AFCEX56B front locking devices as shown below.

To be used with **AFCGX3B** front locking device (right and left)

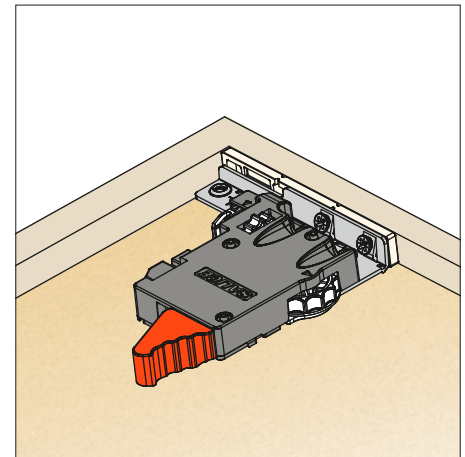
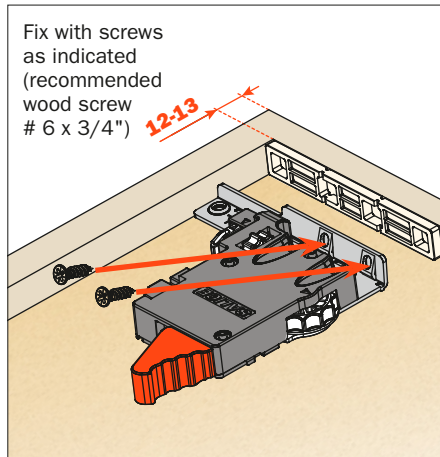
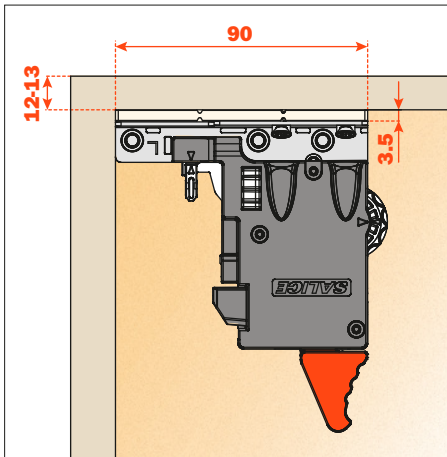

To be used with **AFCEX56B** front locking device (right and left)

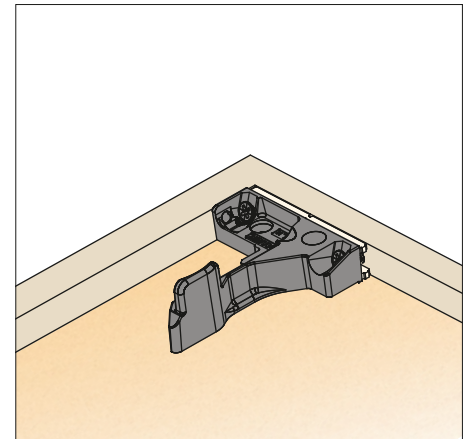
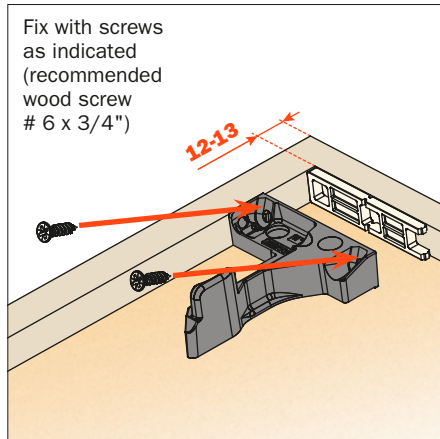
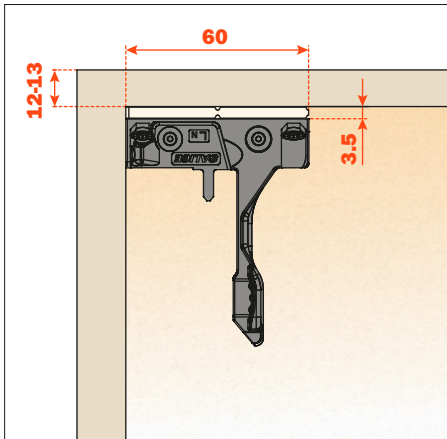

Spacer can be fit to any size by breaking tabs

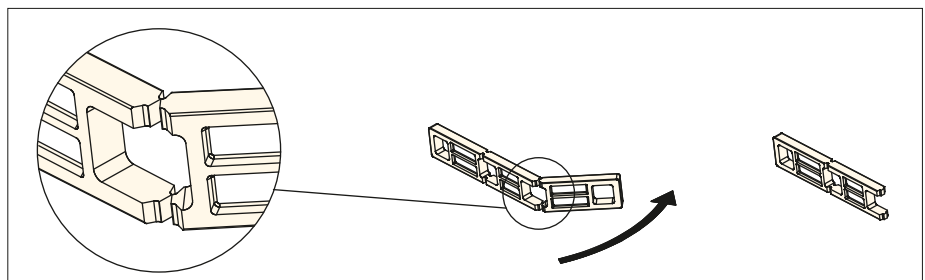

Accessories - For Progressa+ Shelf slides

Rear-fixed bracket and magnet - Lock-open function for runners and drawers

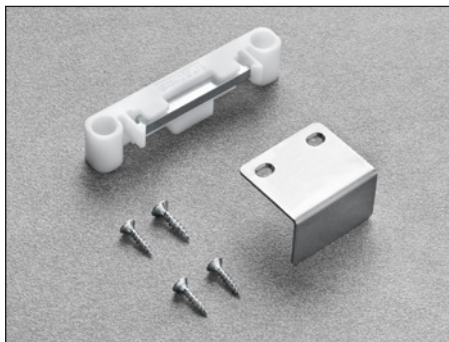

AROSXXY

PACKAGING: 1 box = 20 magnets, 20 brackets. Screws included.

The shelf is held at the maximum opening position by means of a rear-fixed bracket and a magnet.

Rear hook bracket

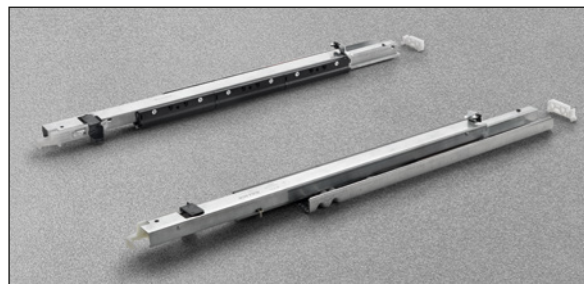
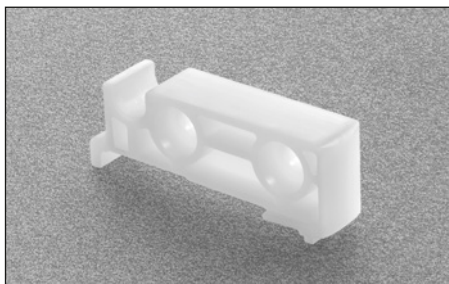

AGAPXXYI

PACKAGING: 1 box = 100 pcs

For shelves that are less than 12 mm thick, the runner can be used together with the rear hook bracket (10 mm thickness) thus eliminating the need for the rear hole in the shelf.

Assembly instructions

1 A) Fix the bracket, aligned with the back of the shelf.

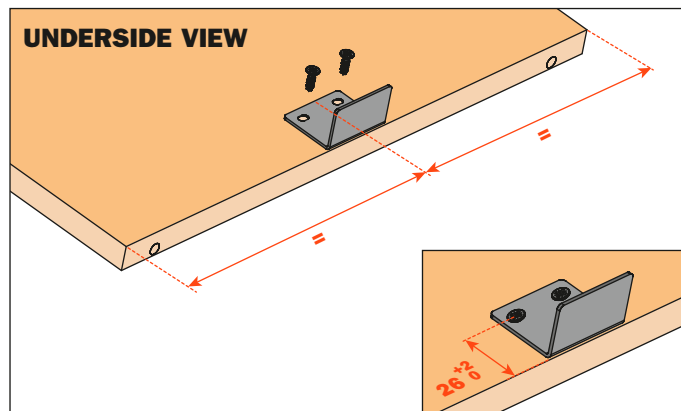

1 B) Fix the bracket to the shelf with the rear hook support. The bracket needs to be aligned to the rear hook support.

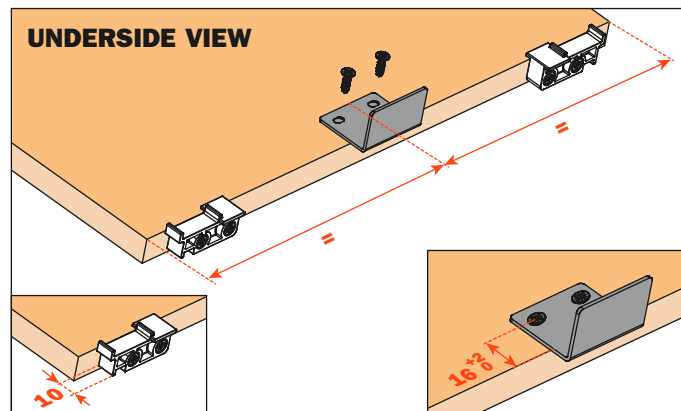

2) Fix the magnet to the bottom.

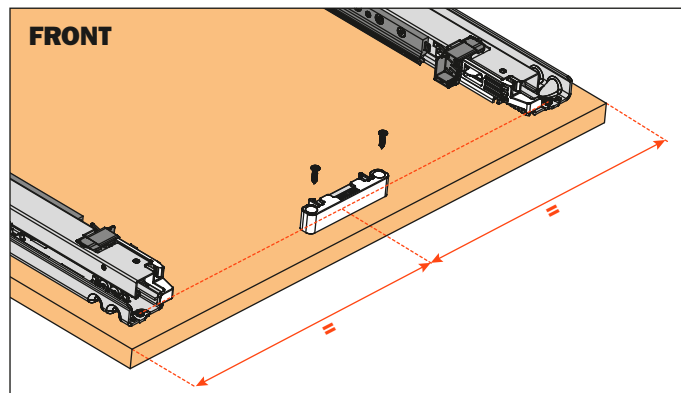

3) The shelf is held at the maximum opening position.

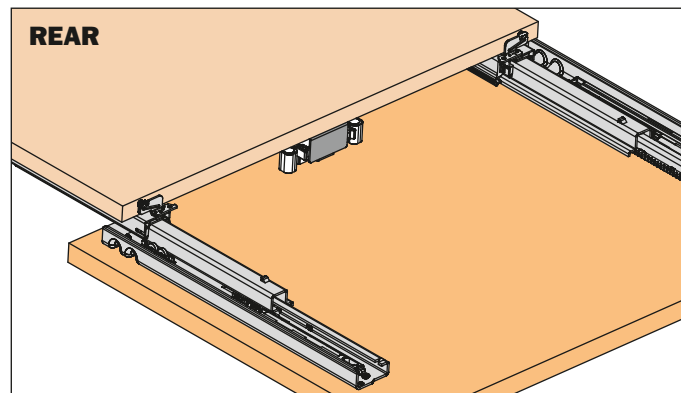

Accessories - For all Progressa, Progressa+ and Progressa+ Shelf slides

Wood screw



V234X164I

PACKAGING: 1 box = 100 pcs

Wood screw # 6 x 16 mm (5/8")

Euro screw

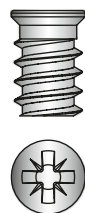

V136X114I

PACKAGING: 1 box = 100 pcs

Euro screw # 6 x 11 mm (7/16")

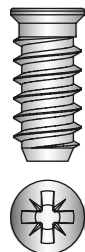

V136X154I

PACKAGING: 1 box = 100 pcs

Euro screw # 6 x 14.5 mm (9/16")

Pozi driver



D2A7XCXCP

PACKAGING: 1 box = 100 pcs

Accessories - For all Progressa, Progressa+ and Progressa+ Shelf slides**∅ 6 mm drill bit for rear hook****TDB7406R**

PACKAGING: 1 box = 1 pc.

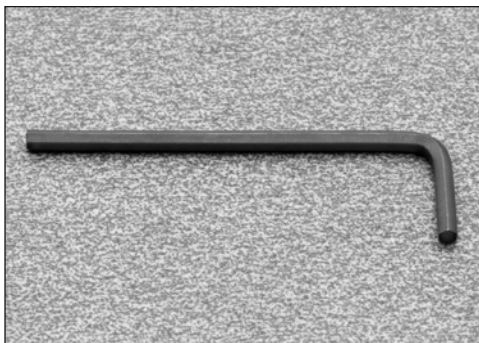
Hex key to lock the stop collar set screw onto the 6 mm drill bit**TLKEY332**

PACKAGING: 1 box = 1 pc.

Drill bit stop collar for 6 mm bit**TSC06MM**

PACKAGING: 1 box = 1 pc.

SALICE AMERICA INC.

2123 CROWN CENTRE DRIVE
CHARLOTTE NC. 28227
TEL. 704 841 7810
FAX. 704 841 7808
info.salice@saliceamerica.com
www.saliceamerica.com



Digital contents