



Series N • 40 mm cup hinge
For profiled and thick doors

SALICE

Series N Hinges • Technical features/Specs

For profiled and thick doors

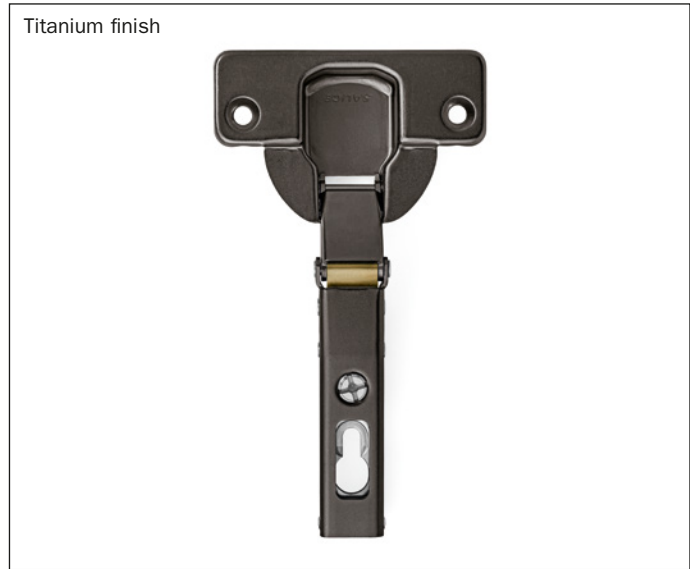
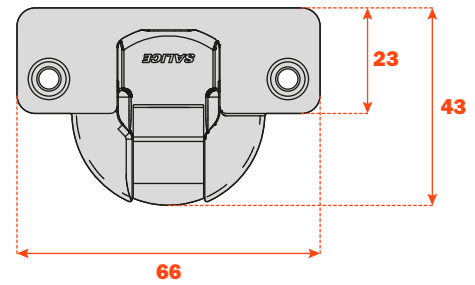

Approx. number of hinges required according to the door dimension and weight.

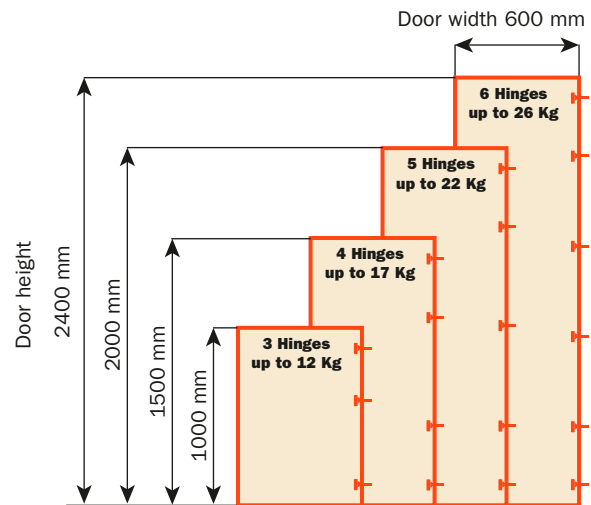
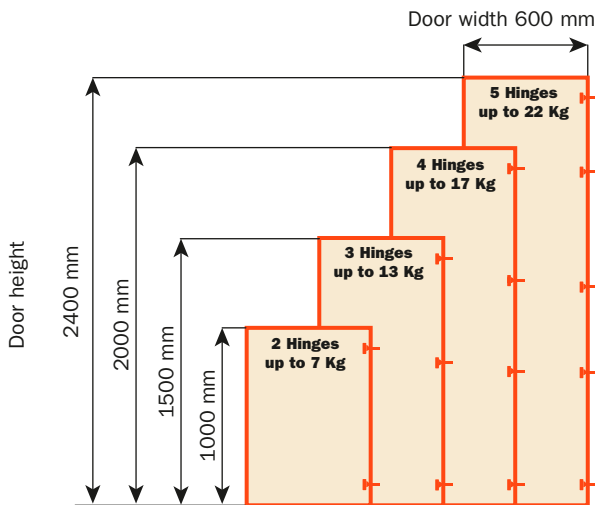

Adjustments

Compensated side adjustment from -1.5 mm to +4.5 mm.
 Height adjustment with any mounting plate ± 2 mm, Constant "L" value of 1 mm (it does not change during side adjustment).
 Depth adjustment with Series 200 mounting plates +2.8 mm.
 Depth adjustment with Domi mounting plates from -0.5 mm to +2.8 mm.

Mounting plates

Symmetrical and asymmetrical bright nickel plated steel or die-cast Series 200 mounting plates.
 Snap-on assembly on Domi mounting plates.
 Positioning with pre-determined stop on traditional Series 200 mounting plates.

N.B. : Use POZIDRIVE No. 2 screwdrivers for all screws.

Series N Hinges - 94° opening

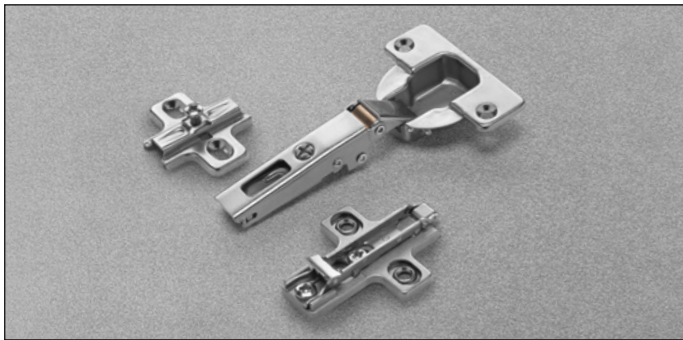

Technical information

**For profiled and thick doors, max. 40 mm.
12 mm deep cup.**
94° opening.
Possible drilling distance on the door (K): from 3 to 14 mm.
Compatible with all mounting plates.
Available in titanium finish.

Space needed to open the door

	T=	20	21	22	23	24	25	26	27	28	29	30	31	32	33	34	35	36	37	38	39	40	L=
K=3	A=	0.3	0.4	0.6	0.7	0.9	1.0	1.2	1.4	1.7	1.9	2.2	2.4	2.9	3.8	4.7	5.7	6.6	7.6	8.6	9.5	10.5	0.0
K=4	A=	0.3	0.4	0.6	0.7	0.9	1.0	1.2	1.4	1.6	1.9	2.1	2.4	2.7	3.2	4.1	5.0	6.0	6.9	7.9	8.8	9.8	0.0
K=5	A=	0.3	0.4	0.6	0.7	0.8	1.0	1.2	1.4	1.6	1.8	2.1	2.4	2.7	3.0	3.5	4.4	5.3	6.2	7.2	8.1	9.1	0.0
K=6	A=	0.3	0.4	0.5	0.7	0.8	1.0	1.2	1.4	1.6	1.8	2.1	2.3	2.6	2.9	3.2	3.9	4.7	5.6	6.6	7.5	8.4	0.0
K=7	A=	0.3	0.4	0.5	0.7	0.8	1.0	1.2	1.4	1.6	1.8	2.0	2.3	2.6	2.9	3.2	3.5	4.2	5.1	6.0	6.9	7.8	0.0
K=8	A=	0.3	0.4	0.5	0.7	0.8	1.0	1.1	1.3	1.5	1.8	2.0	2.3	2.5	2.8	3.1	3.5	3.8	4.6	5.4	6.3	7.2	0.0
K=9	A=	0.3	0.4	0.5	0.7	0.8	1.0	1.1	1.3	1.5	1.7	2.0	2.2	2.5	2.8	3.1	3.4	3.8	4.2	5.0	5.8	6.7	0.0
K=10	A=	0.3	0.4	0.5	0.6	0.8	0.9	1.1	1.3	1.5	1.7	1.9	2.2	2.4	2.7	3.0	3.3	3.7	4.1	4.6	5.4	6.2	0.8
K=11	A=	0.3	0.4	0.5	0.6	0.8	0.9	1.1	1.3	1.5	1.7	1.9	2.2	2.4	2.7	3.0	3.3	3.6	4.0	4.4	5.0	5.8	1.8
K=12	A=	0.3	0.4	0.5	0.6	0.8	0.9	1.1	1.3	1.5	1.7	1.9	2.1	2.4	2.6	2.9	3.2	3.6	3.9	4.3	4.7	5.4	2.8
K=13	A=	0.3	0.4	0.5	0.6	0.8	0.9	1.1	1.2	1.4	1.6	1.9	2.1	2.3	2.6	2.9	3.2	3.5	3.9	4.2	4.6	5.1	3.8
K=14	A=	0.3	0.4	0.5	0.6	0.7	0.9	1.1	1.2	1.4	1.6	1.8	2.1	2.3	2.6	2.8	3.1	3.5	3.8	4.1	4.5	5.0	4.8

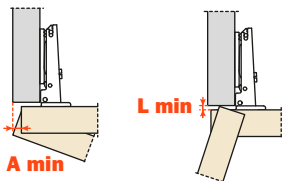

The above values are calculated on the assumption that the doors have square edges. They are reduced if the doors have radiussed edges.

Projection of the door

Projection of the door from the cabinet side at the max. opening. The figures are based on a straight arm hinge, H=0 mm thickness of mounting plate and K value = 3 mm.

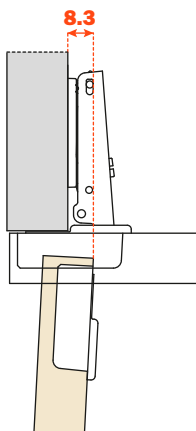

“C” value

With this formula you can obtain the max. thickness of the moulded door that can be opened without touching adjacent carcass sides, doors or walls, whilst bearing in mind the above L-K-T values.

$$C = 27.5 + K + A$$

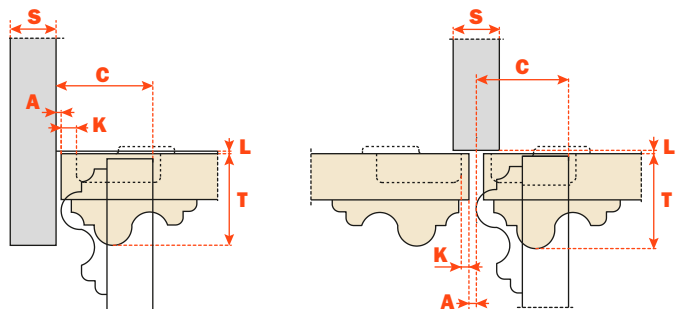

Full and half overlay A, G Crank

Packaging • Boxes 300 pcs. • Pallets 7.200 pcs.

Inset P Crank

Packaging • Boxes 150 pcs. • Pallets 3.600 pcs.

Use these formulas to determine the type of hinge crank, the drilling distance "K" and the height of the mounting plate "H" which is necessary to solve each application problem.

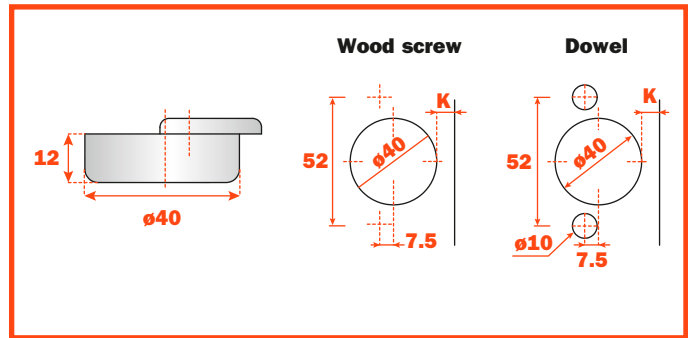

Full overlay/ A crank - 0 mm

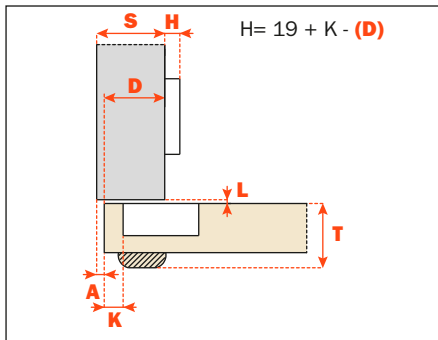

Attachment		Nickel	Titanium
Wood screw	self close	CNA7A99	self close CNA7A66
	free swing	CNA5A99	free swing CNA5A66
Dowel	self close	CNB7A99	self close CNB7A66
	free swing	CNB5A99	free swing CNB5A66

Half overlay/ G crank - 9 mm

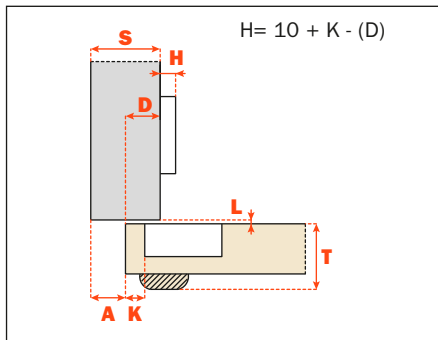

Attachment		Nickel	Titanium
Wood screw	self close	CNA7G99	self close CNA7G66
	free swing	CNA5G99	free swing CNA5G66
Dowel	self close	CNB7G99	self close CNB7G66
	free swing	CNB5G99	free swing CNB5G66

Inset/ P crank - 17 mm

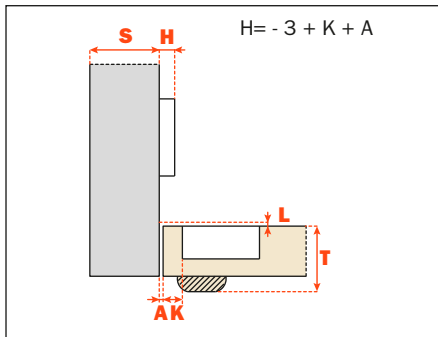

Attachment		Nickel	Titanium
Wood screw	self close	CNA7P99	self close CNA7P66
	free swing	CNA5P99	free swing CNA5P66
Dowel	self close	CNB7P99	self close CNB7P66
	free swing	CNB5P99	free swing CNB5P66

Silentia+ Series N Hinges • Technical features/Specs

For profiled and thick doors

Hinges with adjustable integrated soft-close mechanism operated by twin silicone-oil dampers housed in the hinge cup.

The decelerating effect is adjusted by using a simple switch.

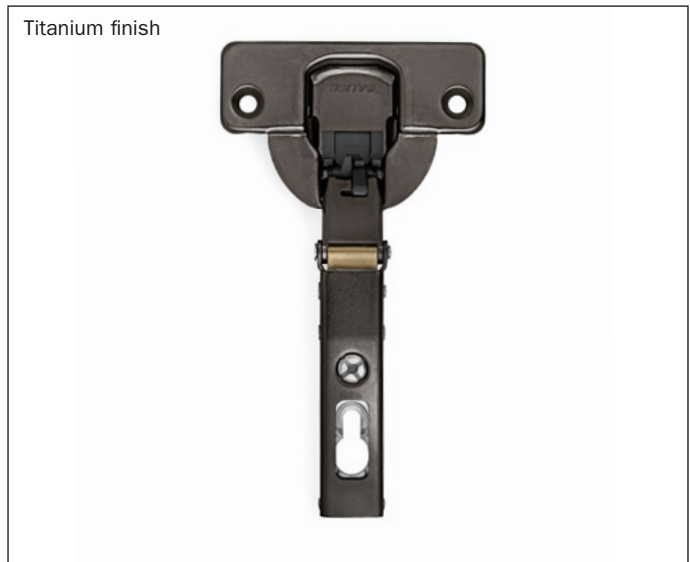
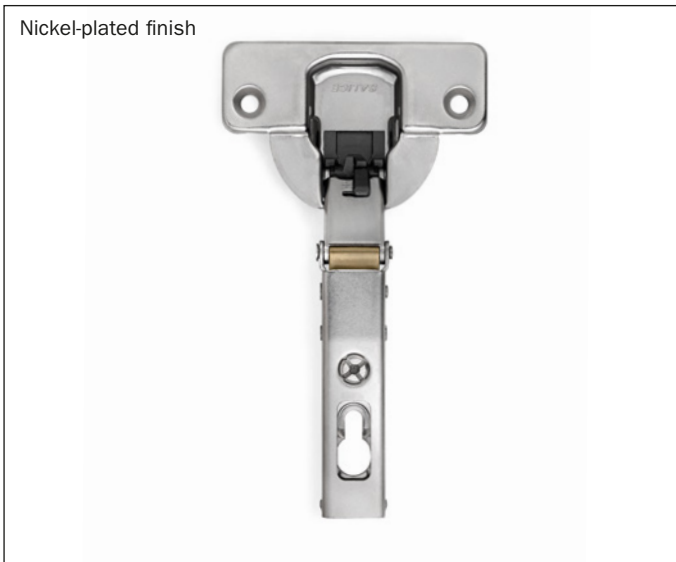
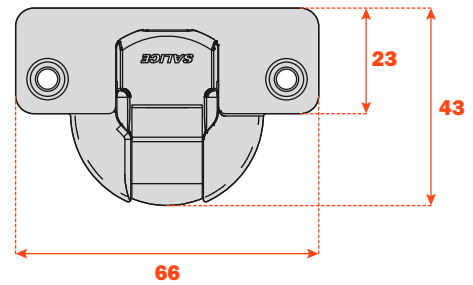

Approx. number of hinges required according to the door dimension and weight.

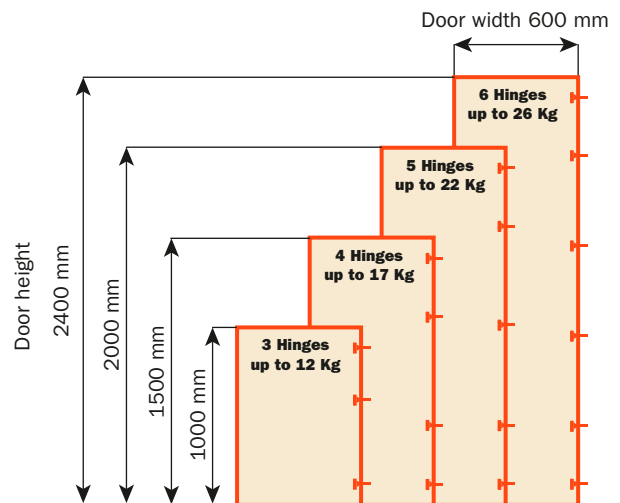
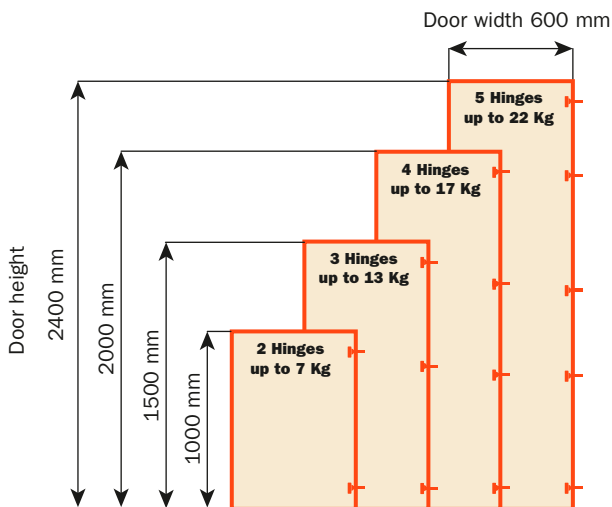

Adjustments

Compensated side adjustment from -1.5 mm to +4.5 mm.
 Height adjustment ± 2 mm, constant "L" value of 1.5 mm (it does not change during side adjustment).
 Depth adjustment with Series 200 mounting plates +2.8 mm.
 Depth adjustment with Domi mounting plates from -0.5 mm to +2.8 mm.

Mounting plates

Symmetrical and asymmetrical bright nickel plated steel or die-cast Series 200 mounting plates.
 Snap-on assembly on Domi mounting plates.
 Positioning with pre-determined stop on traditional Series 200 mounting plates.

N.B. : Use POZIDRIVE No. 2 screwdrivers for all screws.

Silentia+ Series N Hinges - 94° opening



Technical information

Hinges with adjustable integrated soft-close mechanism operated by twin silicone-oil dampers housed in the hinge cup. The decelerating effect is adjusted by using a simple switch.

For profiled and thick doors, max. 40 mm.
15.5 mm deep cup.

94° opening.
Possible drilling distance on the door (K): from 3 to 14 mm.
Compatible with all mounting plates.
Available in titanium finish

Space needed to open the door

	T=	20	21	22	23	24	25	26	27	28	29	30	31	32	33	34	35	36	37	38	39	40	L=
K=3	A=	0.3	0.4	0.6	0.7	0.9	1.0	1.2	1.4	1.7	1.9	2.2	2.4	2.9	3.8	4.7	5.7	6.6	7.6	8.6	9.5	10.5	0.0
K=4	A=	0.3	0.4	0.6	0.7	0.9	1.0	1.2	1.4	1.6	1.9	2.1	2.4	2.7	3.2	4.1	5.0	6.0	6.9	7.9	8.8	9.8	0.0
K=5	A=	0.3	0.4	0.6	0.7	0.8	1.0	1.2	1.4	1.6	1.8	2.1	2.4	2.7	3.0	3.5	4.4	5.3	6.2	7.2	8.1	9.1	0.0
K=6	A=	0.3	0.4	0.5	0.7	0.8	1.0	1.2	1.4	1.6	1.8	2.1	2.3	2.6	2.9	3.2	3.9	4.7	5.6	6.6	7.5	8.4	0.0
K=7	A=	0.3	0.4	0.5	0.7	0.8	1.0	1.2	1.4	1.6	1.8	2.0	2.3	2.6	2.9	3.2	3.5	4.2	5.1	6.0	6.9	7.8	0.0
K=8	A=	0.3	0.4	0.5	0.7	0.8	1.0	1.1	1.3	1.5	1.8	2.0	2.3	2.5	2.8	3.1	3.5	3.8	4.6	5.4	6.3	7.2	0.0
K=9	A=	0.3	0.4	0.5	0.7	0.8	1.0	1.1	1.3	1.5	1.7	2.0	2.2	2.5	2.8	3.1	3.4	3.8	4.2	5.0	5.8	6.7	0.0
K=10	A=	0.3	0.4	0.5	0.6	0.8	0.9	1.1	1.3	1.5	1.7	1.9	2.2	2.4	2.7	3.0	3.3	3.7	4.1	4.6	5.4	6.2	0.8
K=11	A=	0.3	0.4	0.5	0.6	0.8	0.9	1.1	1.3	1.5	1.7	1.9	2.2	2.4	2.7	3.0	3.3	3.6	4.0	4.4	5.0	5.8	1.8
K=12	A=	0.3	0.4	0.5	0.6	0.8	0.9	1.1	1.3	1.5	1.7	1.9	2.1	2.4	2.6	2.9	3.2	3.6	3.9	4.3	4.7	5.4	2.8
K=13	A=	0.3	0.4	0.5	0.6	0.8	0.9	1.1	1.2	1.4	1.6	1.9	2.1	2.3	2.6	2.9	3.2	3.5	3.9	4.2	4.6	5.1	3.8
K=14	A=	0.3	0.4	0.5	0.6	0.7	0.9	1.1	1.2	1.4	1.6	1.8	2.1	2.3	2.6	2.8	3.1	3.5	3.8	4.1	4.5	5.0	4.8

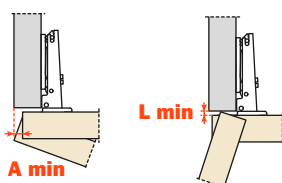

The above values are calculated on the assumption that the doors have square edges. They are reduced if the doors have radiused edges.

Projection of the door

Projection of the door from the cabinet side at the max. opening. The figures are based on a straight arm hinge, H=0 mm thickness of mounting plate and K value = 3 mm.

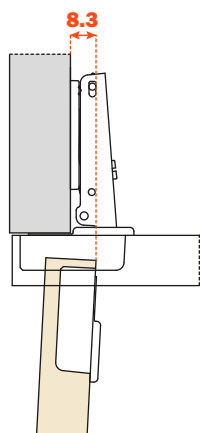

"C" value

With this formula you can obtain the max. thickness of the moulded door that can be opened without touching adjacent carcase sides, doors or walls, whilst bearing in mind the above L-K-T values.

$$C = 27.5 + K + A$$

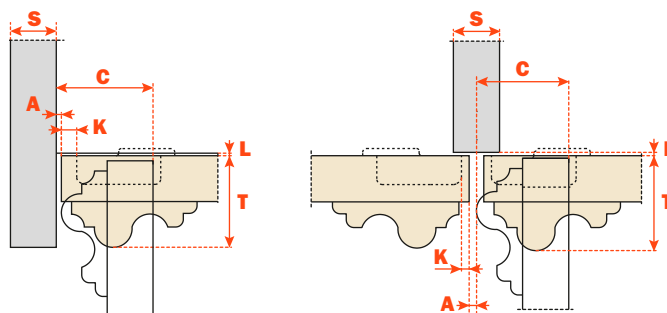

Full and half overlay A, G Crank

Packaging • Boxes 300 pcs. • Pallets 7.200 pcs.

Inset P Crank

Packaging • Boxes 150 pcs. • Pallets 3.600 pcs.

Use these formulas to determine the type of hinge crank, the drilling distance "K" and the height of the mounting plate "H" which is necessary to solve each application problem.

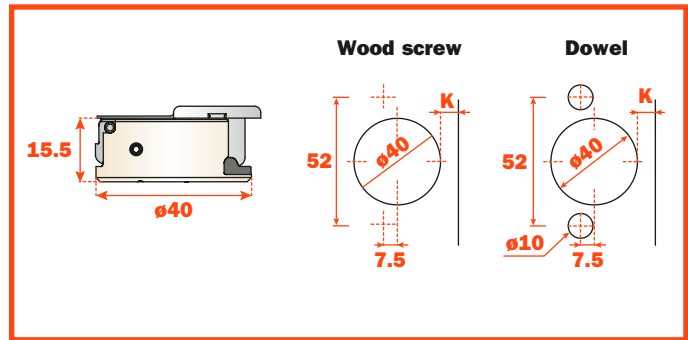

Full overlay/ A crank - 0 mm

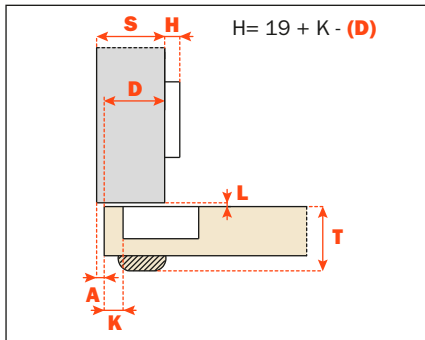

	Attachment	Nickel	Titanium
	Wood screw	CNA7AE9	CNA7AE6
	Dowel	CNB7AE9	CNB7AE6

Half overlay/ G crank - 9 mm

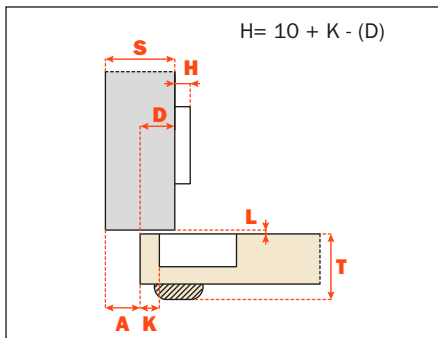

	Attachment	Nickel	Titanium
	Wood screw	CNA7GE9	CNA7GE6
	Dowel	CNB7GE9	CNB7GE6

Inset/ P crank - 17 mm

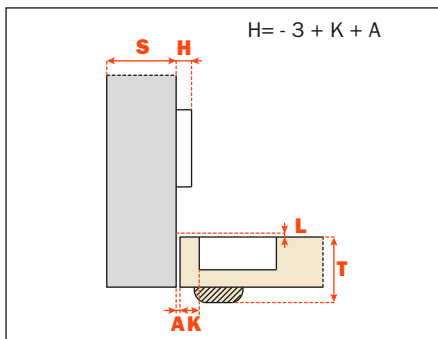

	Attachment	Nickel	Titanium
	Wood screw	CNA7PE9	CNA7PE6
	Dowel	CNB7PE9	CNB7PE6

Series N - Assembly examples

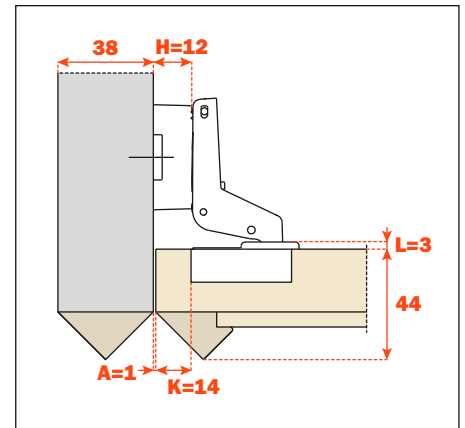
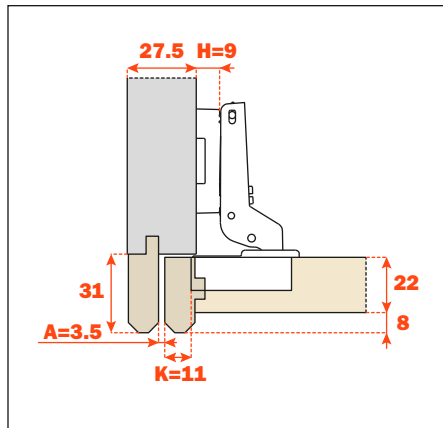
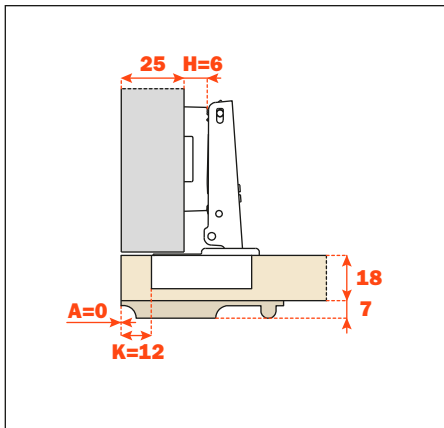
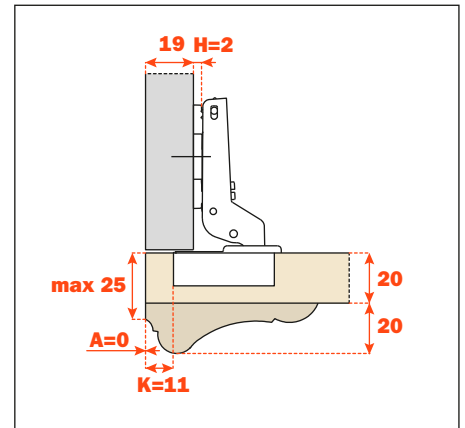
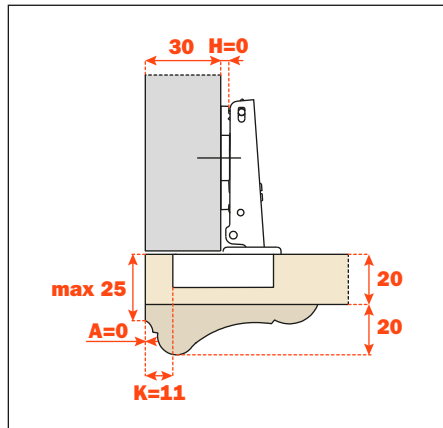
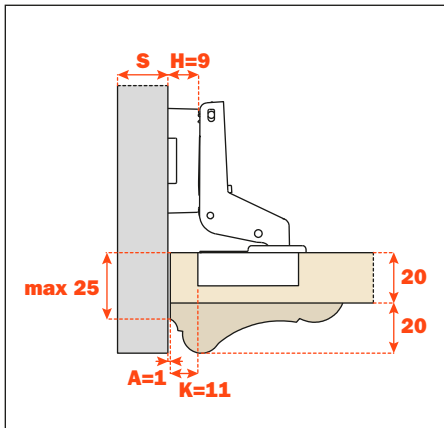
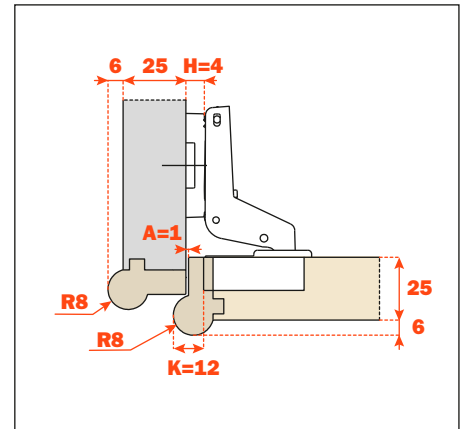
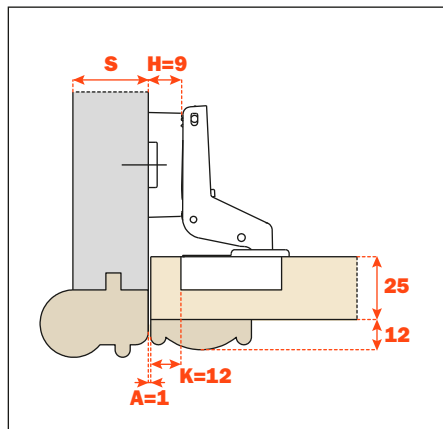
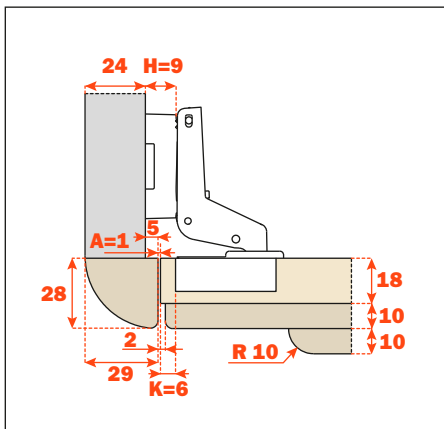
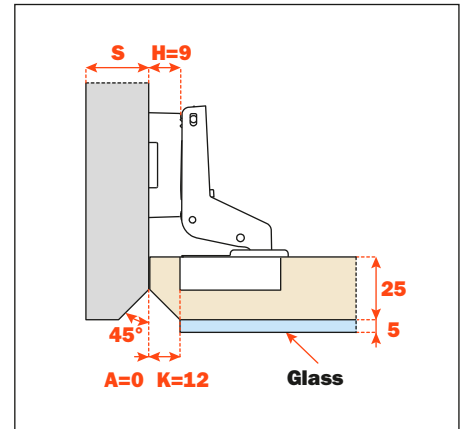
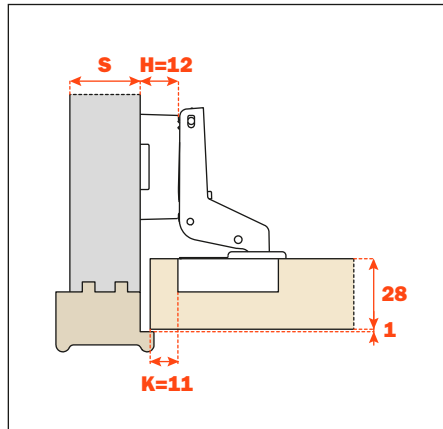
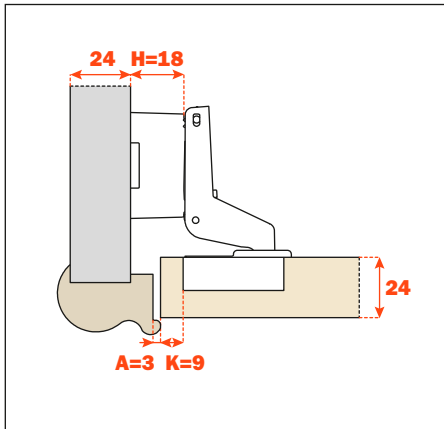



Accessories

Accessories**Screw cover caps.****S2BX83H_**

Symmetrical steel screw cover cap, it can be personalized on request.

S2BX83H6 = Titanium
(special order)
S2BX83H9 = Nickel

S2MX83H_

Symmetrical steel screw cover cap with embossed logo.

S2MX83H6 = Titanium
(special order)
S2MX83H9 = Nickel

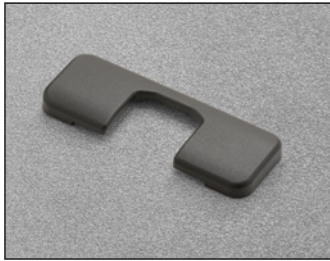
Flange cover caps.**SNXX85A_**

Plastic flange cover cap, it can be personalized on request.

SNXX85A6 = Titanium
(special order)
SNXX85A9 = Nickel

SALICE AMERICA INC.

2123 CROWN CENTRE DRIVE
CHARLOTTE NC. 28227
TEL. 704 841 7810
FAX. 704 841 7808
info.salice@saliceamerica.com
www.saliceamerica.com

SALICE CANADA INC.

3500 RIDGEWAY DRIVE, UNIT#1
MISSISSAUGA, ONTARIO, L5L 0B4
TEL. 905 820 8787
FAX. 905 820 7226
info.salice@salicecanada.com
www.salicecanada.com

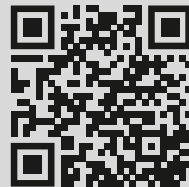

Digital contents