



**Concealed hinges for the cabinet
and furniture industries**

***Charnières invisibles pour l'industrie
du meuble***

SALICE

Index • Index

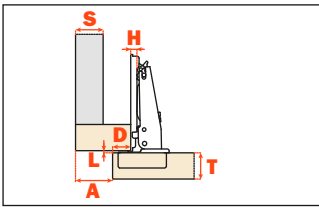

General information
Informations générales

page 4
page 4



100 series Hinges shallow cup
Charnières Série 100 pour portes d'épaisseur réduite

page 12
page 12



200 series Hinges
Charnières Série 200

page 13
page 13

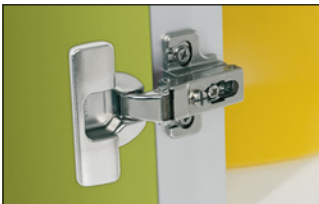

300 series Hinges with small operating profile
Charnières Série 300 avec encombrement en profondeur réduit

page 24
page 24



800 series
Charnières Série 800

page 25
page 25



Universal hinges for wood doors with special profiles
Charnières Universelles pour portes moulurées en bois

page 26
page 26



Single pivot hinge • 270° opening
Charnières à un axe • Ouverture à 270°

page 30
page 30



F series Hinges for thick doors up to 1-1/2"
Charnières Série F pour portes de forte épaisseur jusqu'à 1-1/2"

page 34
page 34

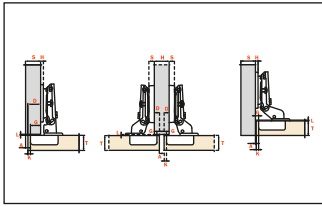

Overlay charts
Graphiques de recouvrement

page 35
page 35



Mounting plates
Embases

page 39
page 39

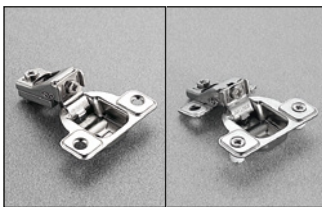

S series "Face frame" EXCENTRA - EXCENTHREE Hinges
Charnières Série S "Face frame" EXCENTRA - EXCENTHREE

page 53
page 53



Accessories
Accessoires

page 58
page 58



Push self opening hinges
Système Push pour l'ouverture de portes sans poignée

page 61
page 61

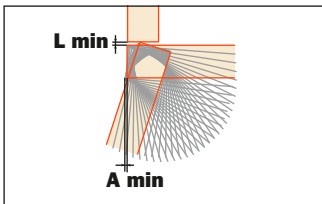

Minimum reveal charts
Tableaux avec jeu nécessaire pour l'ouverture de la porte

page 77
page 77



Titanium finish
Finition titane

page 83
page 83

Table of contents
Index des références

page 86
page 86

General information • Informations générales

Boring Pattern - Series 200, 100, 300, universal hinges, S and 800

K = Boring distance from the edge of the door:

| | |
|------|---------------------|
| 94° | 3 to 9 mm |
| 105° | 3 to 6 mm |
| 106° | 2.5 mm (Face Frame) |
| 110° | 3 to 6 mm |
| 120° | 3 to 6 mm |
| 155° | 3 to 9 mm |
| 165° | 3 to 8 mm |

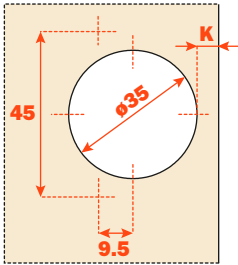

Screw-in.
A visser

Schéma de perçage - Série 200, 100, 300, charnières universelles, S et 800

K = Distance de perçage :

| | |
|------|---------------------|
| 94° | 3 à 9 mm |
| 105° | 3 à 6 mm |
| 106° | 2.5 mm (Face Frame) |
| 110° | 3 à 6 mm |
| 120° | 3 à 6 mm |
| 155° | 3 à 9 mm |
| 165° | 3 à 8 mm |

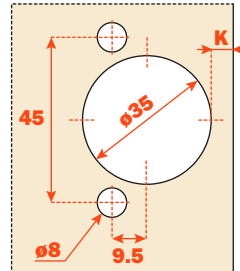

Press-in - Rapido - Logica Tool free
A pression - Rapido - Logica, sans outils

System 37x32 standard drilling for cruciform plates

Perçage standard 37x32 pour embases cruciformes

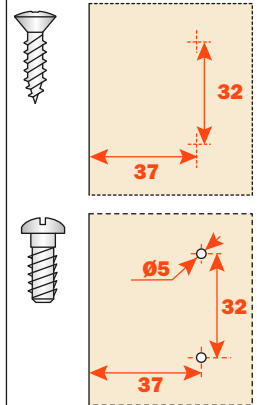

Recommended number of hinges per door.

Maximum door weight.

| | | | |
|---------------|------|------|------|
| ø 40 mm | 20lb | 40lb | 60lb |
| ø 35 mm | 20lb | 40lb | 60lb |
| No. of hinges | 2 | 3 | 4 |

The number of hinges required depends on the size, weight and material of the door. The distance between the top and bottom must be greater than the width of the door. Additional hinges should be added if doors are near the border line of size or weight chart. Use the diagram below to determine number of hinges needed.

Nombre de charnières requises par porte.

Poids maximum de la porte

| | | | |
|----------------------|------|------|------|
| ø 40 mm | 20lb | 40lb | 60lb |
| ø 35 mm | 20lb | 40lb | 60lb |
| Nombre de charnières | 2 | 3 | 4 |

Le nombre de charnières nécessaires dépend des dimensions, du poids et de la matière de la porte. La distance entre le chapeau et la base doit être supérieure à la largeur de la porte. Des charnières supplémentaires doivent être ajoutées si les portes sont proches aux limites du tableau des dimensions ou du poids. Utilisez le schéma ci-dessous pour déterminer le nombre de charnières nécessaires.

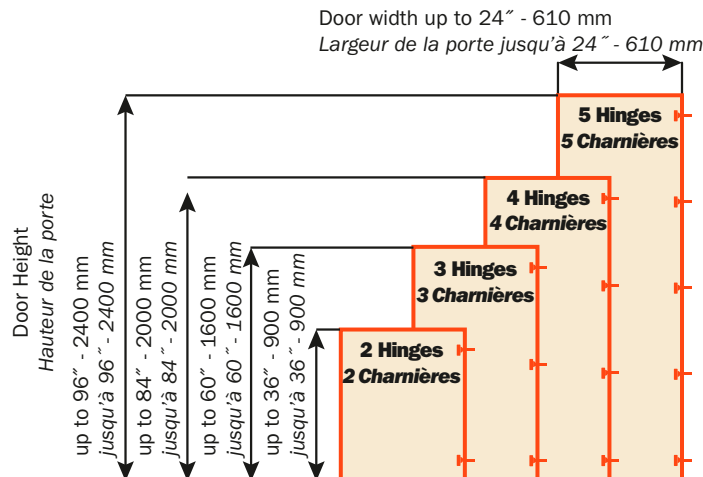

Millimeter to inch equivalents • Correspondance entre pouce et millimètre

| | | | | | | | | | | | | | | | | |
|------|-------|--------|-------|--------|--------|--------|-------|--------|--------|--------|--------|--------|--------|--------|--------|------|
| mm | 1 | 1.5 | 2 | 3 | 4 | 5 | 5.5 | 6 | 7 | 8 | 9 | 9.5 | 10 | 11 | 12 | 13 |
| inch | 1/32" | 1/16" | 3/32" | 1/8" | 5/32" | 3/16" | 7/32" | 1/4" | 9/32" | 5/16" | 11/32" | 3/8" | 13/32" | 7/16" | 15/32" | 1/2" |
| mm | 14 | 15 | 16 | 17 | 17.5 | 18 | 19 | 20 | 20.5 | 21 | 22 | 23 | 24 | 24.5 | 25.4 | |
| inch | 9/16" | 19/32" | 5/8" | 21/32" | 11/16" | 23/32" | 3/4" | 25/32" | 13/16" | 27/32" | 7/8" | 29/32" | 15/16" | 31/32" | 1" | |

How to calculate your overlay using the 100/200 series:
Comment calculer le recouvrement en utilisant les Série 100/200 :

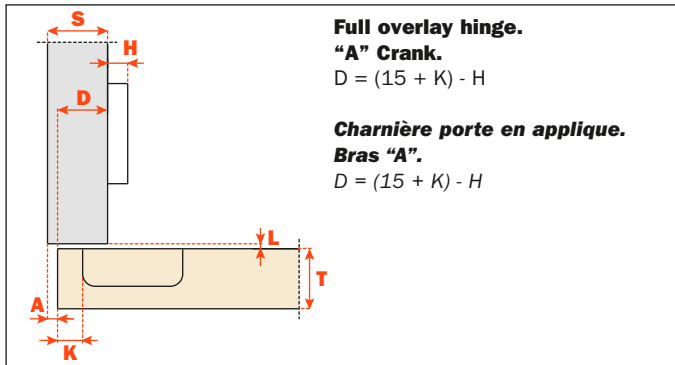

Full overlay hinge.
"A" Crank.
 $D = (15 + K) - H$

Charnière porte en applique.
Bras "A".
 $D = (15 + K) - H$

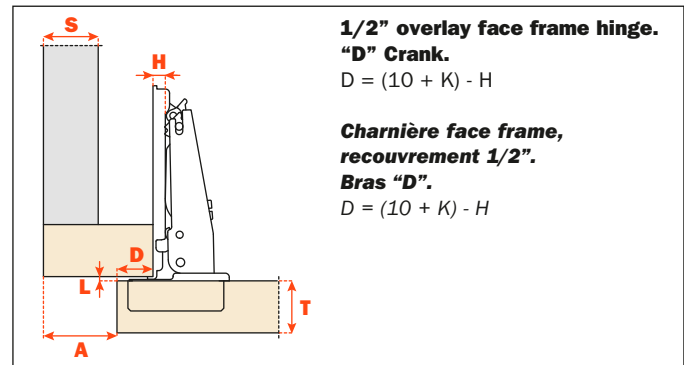

1/2" overlay face frame hinge.
"D" Crank.
 $D = (10 + K) - H$

Charnière face frame, recouvrement 1/2".
Bras "D".
 $D = (10 + K) - H$

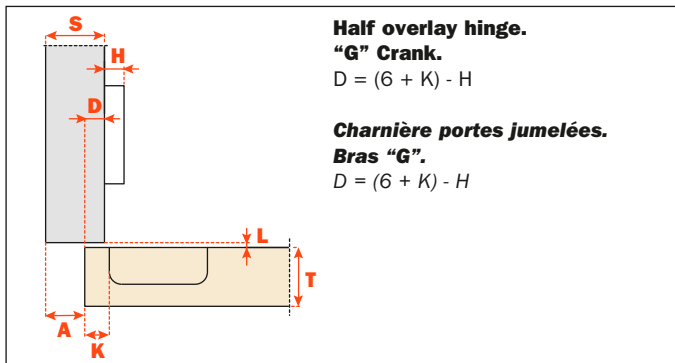

Half overlay hinge.
"G" Crank.
 $D = (6 + K) - H$

Charnière portes jumelées.
Bras "G".
 $D = (6 + K) - H$

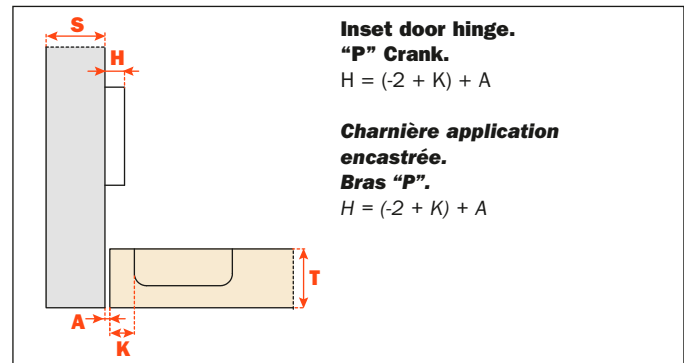

Inset door hinge.
"P" Crank.
 $H = (-2 + K) + A$

Charnière application encastrée.
Bras "P".
 $H = (-2 + K) + A$

Overlay = (constant + drilling distance) - plate height.

For special applications, do not hesitate to contact our customer service department.

Recouvrement = (constante + distance de perçage) - hauteur

embase. N'hésitez pas à demander toutes les explications nécessaires à notre service d'assistance technique.

Boring Pattern - F series • Schéma de perçage - Série F

How to calculate your overlay:

Comment calculer le recouvrement :

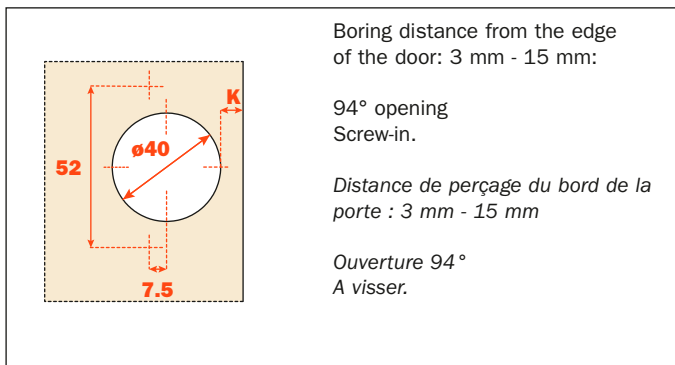

Boring distance from the edge of the door: 3 mm - 15 mm:

94° opening
Screw-in.

Distance de perçage du bord de la porte : 3 mm - 15 mm

Ouverture 94°
A visser.

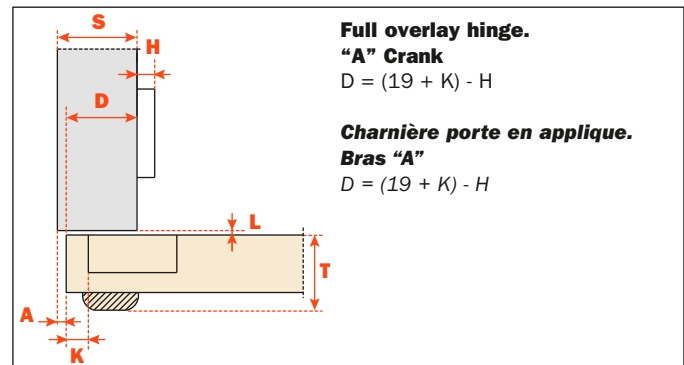

Full overlay hinge.
"A" Crank
 $D = (19 + K) - H$

Charnière porte en applique.
Bras "A"
 $D = (19 + K) - H$

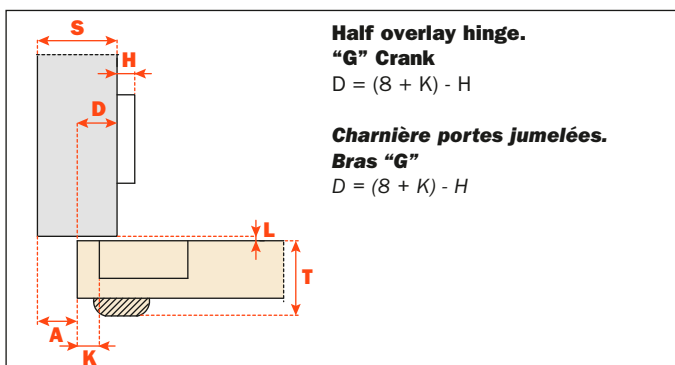

Half overlay hinge.
"G" Crank
 $D = (8 + K) - H$

Charnière portes jumelées.
Bras "G"
 $D = (8 + K) - H$

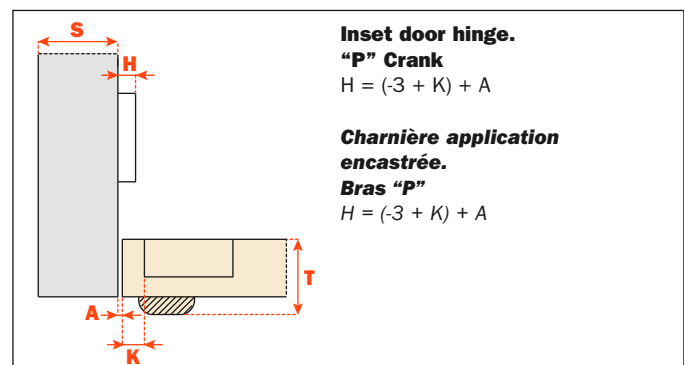

Inset door hinge.
"P" Crank
 $H = (-3 + K) + A$

Charnière application encastrée.
Bras "P"
 $H = (-3 + K) + A$

Abbreviations • Abréviations

Application with full overlay door.
Application avec porte en applique.

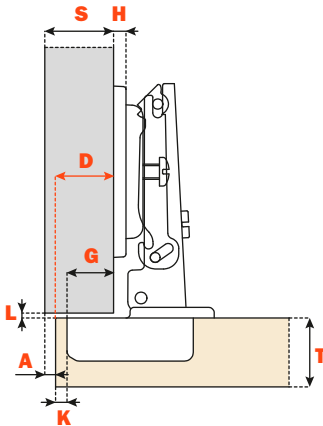

Application with half overlay door.
Application avec portes jumelées.

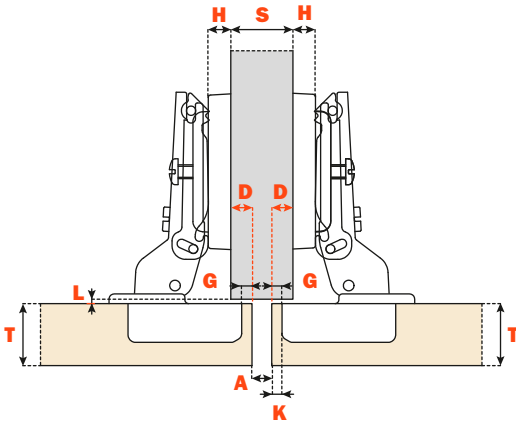

Application with inset door.
Application avec porte rentrante.

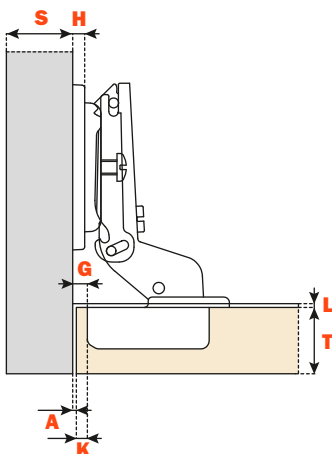

S = Thickness of the cabinet side - *Epaisseur du côté*

D = Required door overlay - *Recouvrement désiré*

T = Door thickness - *Epaisseur de la porte*

K = Drilling distance - *Distance de perçage*

A = Reveal - *Jeu*

L = Gap between door and cabinet - *Distance entre la porte et le côté*

H = Height of the mounting plate - *Hauteur de l'embase*

G = Hinge constant - *Caractéristique de la charnière*

Whatever door overlay is required, you can select from our series the combination of both the type of hinge arm and the thickness of mounting plate necessary to solve your construction problem while avoiding the need to stock unnecessary components.

Quel que soit le recouvrement de la porte sur le côté que vous désirez, vous pouvez compter sur une large gamme de bras droits, de bras coudés, de hauteurs d'embases, qui vous permettront de réaliser votre projet, en gérant de façon rationnelle votre stock.

S = Thickness of the cabinet side - *Epaisseur du côté*

T = Door thickness - *Epaisseur de la porte*

K = Drilling distance - *Distance de perçage*

A = Reveal - *Jeu*

L = Gap between internal face of door and internal cabinet elements (e.g. shelves, drawers, etc.)

Distance intérieure de la porte/éléments à l'intérieur du meuble (consoles, tiroirs, etc.)

H = Height of the mounting plate - *Hauteur de l'embase*

G = Hinge constant - *Caractéristique de la charnière*

Whatever door overlay is required, you can select from our series the combination of both the type of hinge arm and the thickness of mounting plate necessary to solve your construction problem while avoiding the need to stock unnecessary components.

Quel que soit le recouvrement de la porte sur le côté que vous désirez, vous pouvez compter sur une large gamme de bras droits, de bras coudés, de hauteurs d'embases, qui vous permettront de réaliser votre projet, en gérant de façon rationnelle votre stock.

Height adjustment • Please use #2 Pozidrive screwdriver for all screws
Réglage vertical • Utiliser le tournevis POZIDRIVE n° 2 pour toutes les vis

Traditional height adjustment.

By loosening the two fixing screws it is possible to adjust the door vertically by ± 2 mm. The elongated holes allow the mounting plate to slide freely in both directions. The screws must be retightened.

Réglage vertical traditionnel.

En dévissant les deux vis de fixation, il est possible de régler verticalement la porte ± 2 mm. Les trous ovales permettent le glissement de l'embase dans les deux sens. Une fois l'opération terminée, les vis doivent être resserrées.

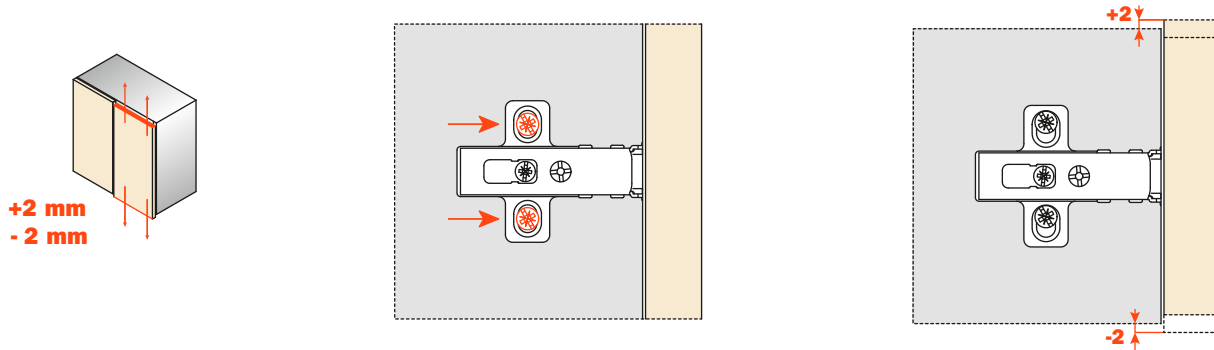

Height adjustment with Domi snap-on mounting plates, model BARxR.

Height adjustment is made without loosening any screws. The door can be moved vertically ± 2 mm simply by rotating the cam adjuster incorporated in this series of mounting plates.

Réglage vertical avec embases Domi modèle BARxR -

Il est possible d'effectuer un réglage vertical de la porte de ± 2 mm par une vis excentrique, sans avoir à dévisser une seule vis.

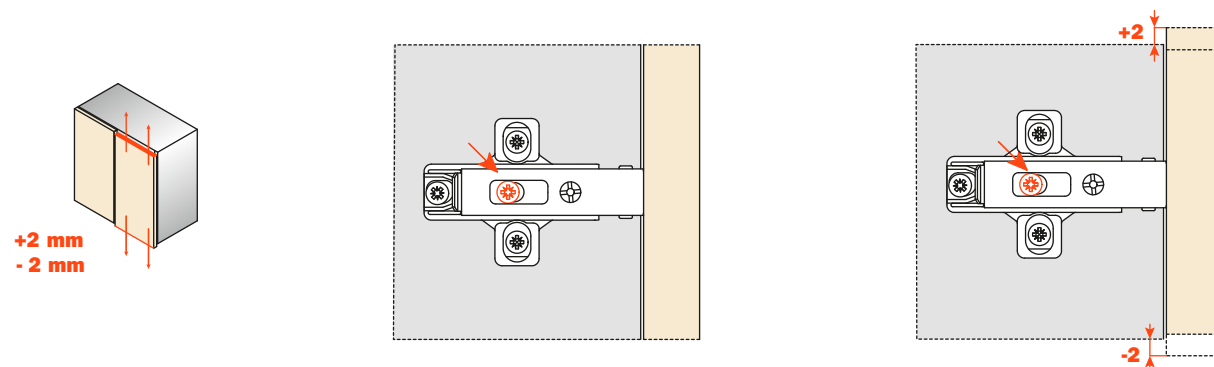

Height adjustment by cam • Réglage vertical par vis excentrique

Height adjustment with DOMI snap-on mounting plates, model BAPxR.

Height adjustment is made without loosening any screws. The door can be moved vertically ± 2 mm simply by rotating the cam adjuster incorporated in this series of mounting plates.

Réglage vertical avec embases Domi modèle BAPxR -

Il est possible d'effectuer un réglage vertical de la porte de ± 2 mm par une vis excentrique, sans avoir à dévisser une seule vis.

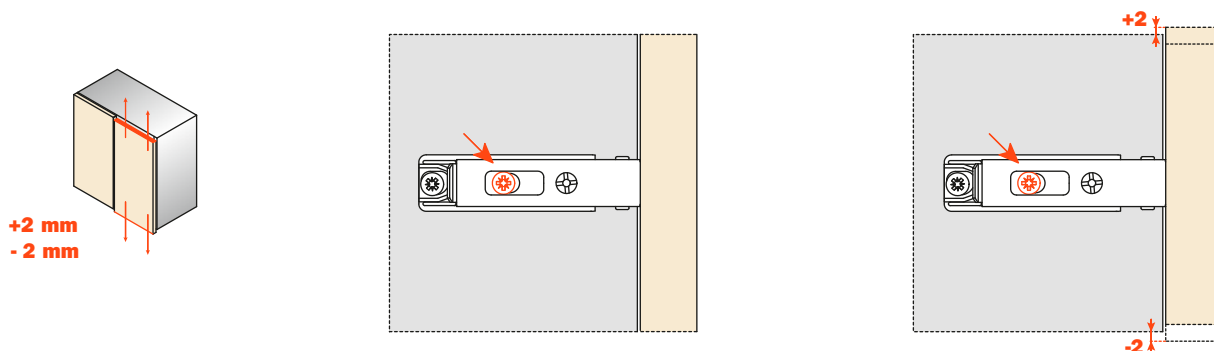

Height adjustment by cam • Réglage vertical par vis excentrique

Depth adjustment • Please use #2 Pozidrive screwdriver for all screws Réglage frontal • Utiliser le tournevis POZIDRIVE n° 2 pour toutes les vis

Traditional depth adjustment.

The hinge fixing screw is loosened and a key hole on the arm of the hinge enables the door to be adjusted out by +2.8 mm. The fixing screw must be retightened.

Réglage frontal traditionnel

Il est possible d'effectuer un réglage frontal de la porte de +2.8 mm. Le trou ovale placé sur la plaquette de l'embase permet le glissement de la charnière. Une fois l'opération terminée, la vis doit être resserrée.

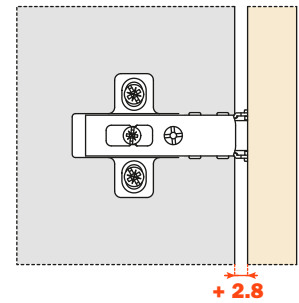
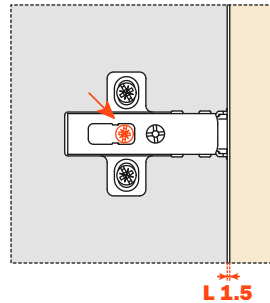
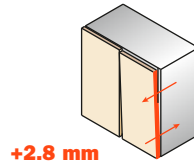

Traditional depth adjustment with Series 800 hinges

The hinge fixing screw is slackened and an oval slot on the arm of the hinge enables the door to be adjusted frontally from -1.5 mm to +3 mm. Finally the fixing screw must be retightened.

Réglage frontal traditionnel Série 800

Il est possible d'effectuer un réglage frontal de la porte de -1.5 mm à +3 mm. Le trou ovale permet le glissement de la charnière. Une fois l'opération terminée, la vis doit être resserrée.

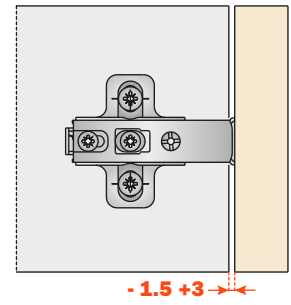
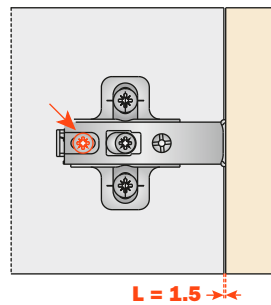
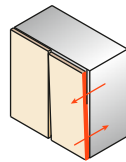

Depth adjustment with DOMI® snap-on mounting plates model BARxR.

Frontal adjustment is made without loosening any screws. The door can be moved frontally from -0.5 to +2.8 mm simply by rotating the cam adjuster in this series of mounting plates.

Réglage frontal avec embases Domi, modèle BARxR.

Il est possible d'effectuer un réglage frontal de la porte de -0.5 mm à +2.8 mm par une vis excentrique, sans avoir à dévisser une seule vis.

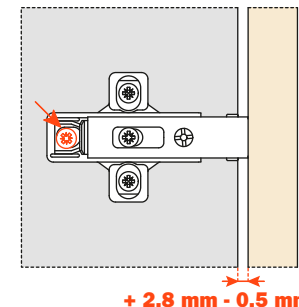
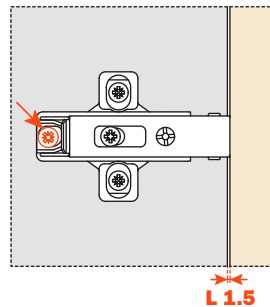
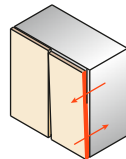

+2.8 mm
- 0.5 mm

Depth adjustment by cam • Réglage frontal par vis excentrique

Depth adjustment with DOMI® snap-on mounting plates model BAPxR.

Frontal adjustment is made without loosening any screws. The door can be moved frontally from -0.5 to +2.8 mm simply by rotating the cam adjuster in this series of mounting plates.

Réglage frontal avec embases Domi - modèle BAPxR

Il est possible d'effectuer un réglage frontal de la porte de -0.5 mm à +2.8 mm par une vis excentrique, sans avoir à dévisser une seule vis.

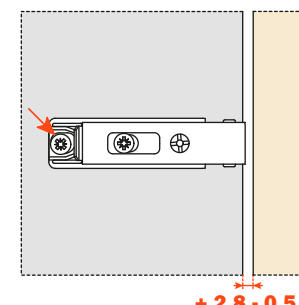
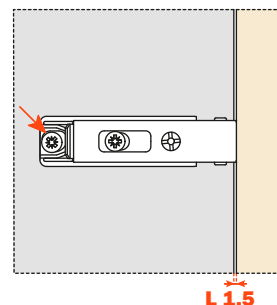
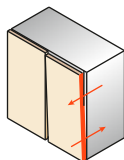

Side adjustments • Please use #2 Pozidrive screwdriver for all screws

Réglage latéral • Utiliser le tournevis POZIDRIVE n° 2 pour toutes les vis

Side to side adjustment of the door with 100, 200, F and Universal hinges.

Réglage latéral de la porte avec charnières Série 100, 200, F et charnières universelles.

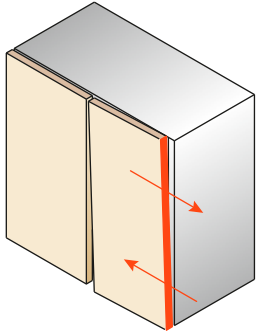

An ingenious adjustment system allows the door to be moved laterally without changing the gap behind the door (the "L" value of 1.5 mm remains constant).

Compensating side adjustment. A patented system exclusive to all Salice 100, 200, F and universal hinges.

Une technique spéciale de réglage latéral permet un déplacement de la porte en maintenant la même valeur "L" de 1.5 mm.

Réglage latéral compensé. C'est une exclusivité sur toutes les charnières Salice Série 100, 200, F et charnières universelles

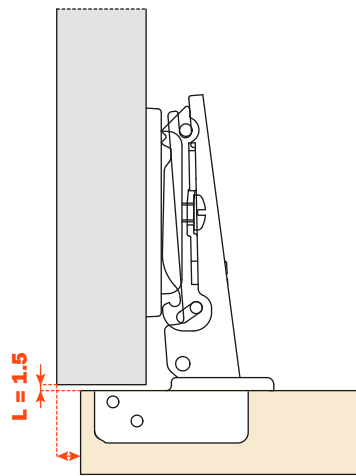
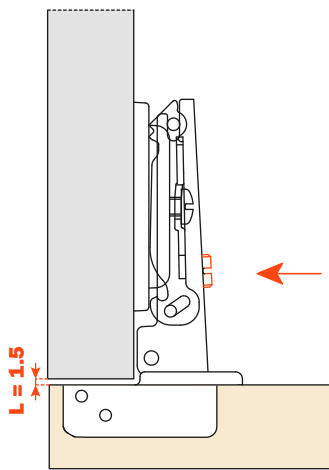

**-1.5 +4.5 mm (100, 200, and universal hinges/ série 100, 200 et charnières universelles)
-0.5 +5.5 mm (F series/ série F)**

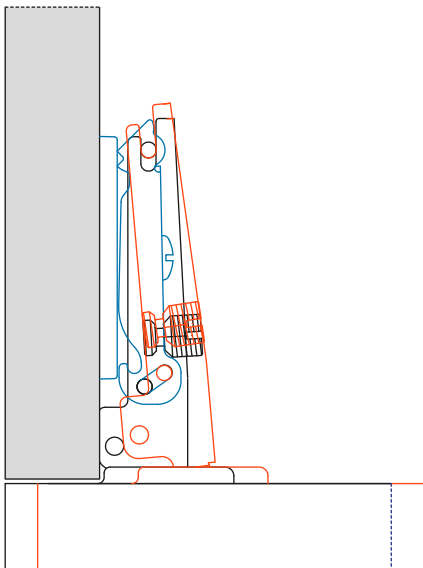

The adjustment screw operates in conjunction with the inner leaf of the hinge arm. The door moves in only one direction - parallel to the carcass and without a gap developing between the door and the carcass. No further adjustments are necessary. There is no gap to reduce.

Sideways adjustment of the door with Series 800 hinges.

Sideways adjustment of the door is made by using the indicated screw. It is possible to recover the gap behind the door by simply using the assembly stop located on the underside of the hinge.

La vis de réglage agit en faisant avancer le bras de la charnière.

La porte se déplace par rapport au côté en évitant tout détachement.

Des opérations d'ajustage, par la suite, ne sont plus nécessaires.

Réglage latéral de la porte avec charnières Série 800.

Régler latéralement la porte en agissant sur la vis indiquée. En utilisant la butée de montage présente sur le bras de la charnière, il est possible de conserver, lors de ce réglage.

Assembly instructions • 100, 200, F and universal hinges series Instructions de montage • Série 100, 200, F et charnières universelles

Assembly with 200 series traditional mounting plates.
Montage traditionnel avec embases Série 200.

Assembly with DOMI® snap-on mounting plates.
Montage avec embases Domi à fixation rapide.

- 1** Place the hinge onto the mounting plate.
Push the hinge up to the pre-determined stop under the hinge arm.

*Poser la charnière sur l'embase.
Positionnement avec butée en fin de course.*

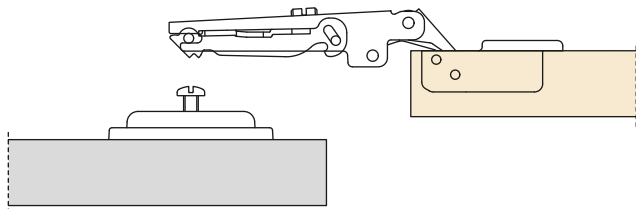

- 1** Locate the lugs on the mounting plate into the "J" hooks beneath the arm.

Mettre en contact les deux points comme indiqué par la flèche.

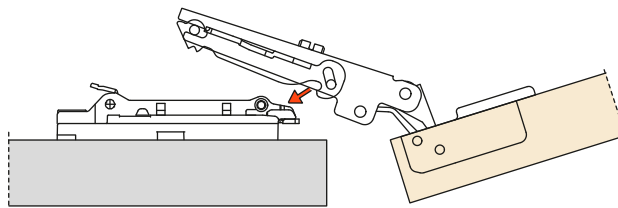

- 2** Tighten the fixing screw.
Serrer la vis de fixation.

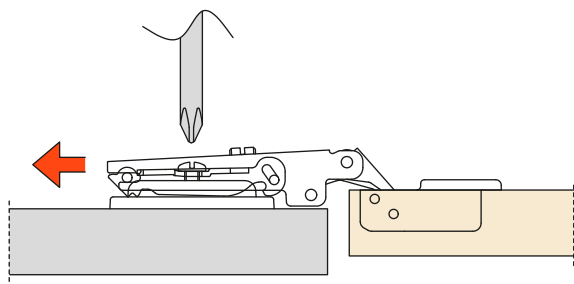

- 2** Gently rotate the hinge arm in the direction shown.
Marquer une légère rotation.

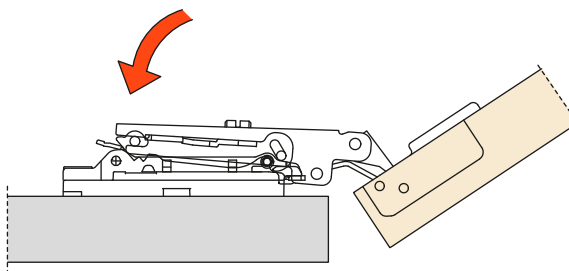

- 3** An «L» value of 1.5 mm between door and cabinet side is achieved on final assembly.

Après montage de la porte subsiste un valeur "L" de 1.5 mm.

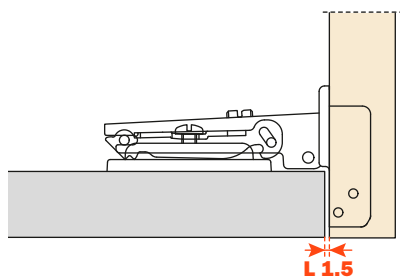

- 3** Then press lightly on the end of the arm to engage the catch.
Ensuite presser légèrement.

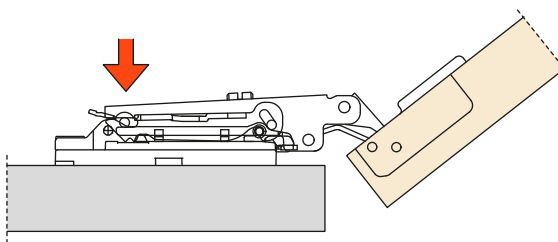

- 4** "Key hole" safety feature.
Dispositif de sécurité.

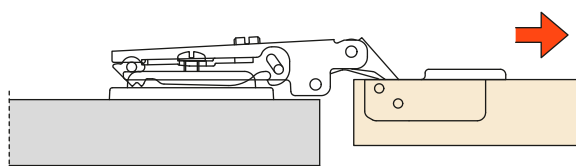

- 4** To remove the hinge from the mounting plate, press gently in the places shown by the arrows.

Pour décrocher la charnière de l'embase, exercer une pression sur les points indiqués.

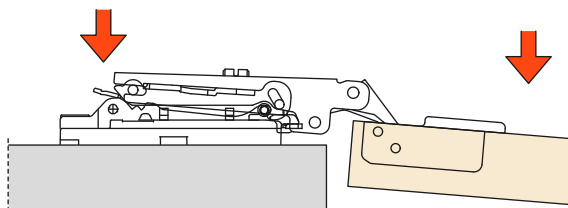





Hinges • Charnières

100 series • Hinges for thin doors (1/2") or doors with deep profiles - 105°

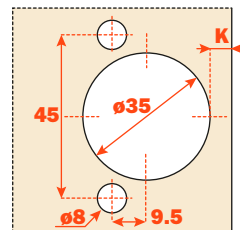

Série 100 • Charnières pour portes d'épaisseur réduite (1/2") ou portes avec profils profonds - 105°

| | | |
|--|---|------------------------|
| | 105° ø35 | Packaging Emballage |
| |  | |



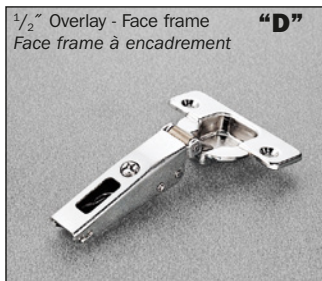
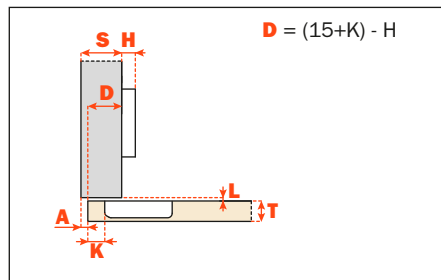

| | | | |
|------------|---|---------|-----|
| S/C |  | C1P6A99 | 300 |
| S/C |  | C1R6A99 | 300 |
| | | | |
| | | | |
| | | | |



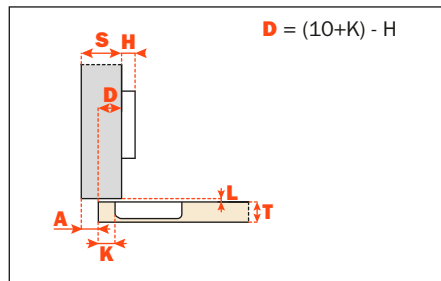

| | | | |
|------------|---|---------|-----|
| S/C |  | C1P6D99 | 300 |
| S/C |  | C1R6D99 | 300 |
| | | | |
| | | | |
| | | | |



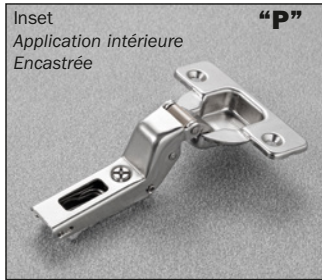
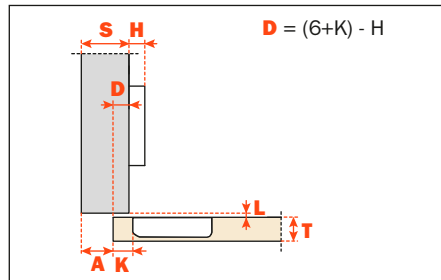

| | | | |
|------------|---|---------|-----|
| S/C |  | C1P6G99 | 300 |
| S/C |  | C1R6G99 | 300 |
| | | | |
| | | | |
| | | | |



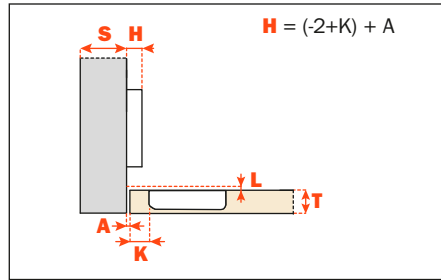





| | | | |
|------------|---|---------|-----|
| S/C |  | C1P6P99 | 300 |
| S/C |  | C1R6P99 | 300 |
| | | | |
| | | | |
| | | | |









200 series • For kitchen cabinets and furniture
Série 200 • Pour meubles de cuisine et armoires

| | | | |
|--|---|--|------------------------|
| | 110° ø35 | 120° ø35 | Packaging Emballage |
| |  |  | |









| | | | | |
|------------|---|---------|---------|-----|
| F/S |  | C2P4A99 | C2P8A99 | 300 |
| F/S |  | C2R4A99 | C2R8A99 | 300 |
| S/C |  | C2P6A99 | C2P9A99 | 300 |
| S/C |  | C2R6A99 | C2R9A99 | 300 |
| S/C |  | C276A99 | C279A99 | 300 |
| S/C |  | C2J6A99 | C2J9A99 | 300 |









| | | | | |
|------------|---|---------|---------|-----|
| F/S |  | C2P4D99 | C2P8D99 | 300 |
| F/S |  | C2R4D99 | C2R8D99 | 300 |
| S/C |  | C2P6D99 | C2P9D99 | 300 |
| S/C |  | C2R6D99 | C2R9D99 | 300 |
| S/C |  | C276D99 | C279D99 | 300 |
| S/C |  | C2J6D99 | C2J9D99 | 300 |



| | | | | |
|------------|---|---------|---------|-----|
| F/S |  | C2P4G99 | C2P8G99 | 300 |
| F/S |  | C2R4G99 | C2R8G99 | 300 |
| S/C |  | C2P6G99 | C2P9G99 | 300 |
| S/C |  | C2R6G99 | C2R9G99 | 300 |
| S/C |  | C276G99 | C279G99 | 300 |
| S/C |  | C2J6G99 | C2J9G99 | 300 |



| | | | | |
|------------|---|---------|--|-----|
| F/S |  | C2P4P99 | | 300 |
| F/S |  | C2R4P99 | | 300 |
| S/C |  | C2P6P99 | | 300 |
| S/C |  | C2R6P99 | | 300 |
| S/C |  | C276P99 | | 300 |
| S/C |  | C2J6P99 | | 300 |

Legend - Notes explicatives:



Screw-in
A visser



Press-in
Tourillon à
pression



Rapido
Rapido



Logica
Logica

F/S = Free Swinging - Sans ressort
S/C = Self-closing - Avec ressort

200 Series • For kitchen cabinets and furniture Série 200 • Pour meubles de cuisine et armoires

| | | |
|--|---|------------------------|
| | 165° ø35 | Packaging Emballage |
| |  | |



| | | | |
|------------|--|---------|-----|
| F/S | | C2PEA99 | 100 |
| F/S | | C2REA99 | 100 |
| S/C | | C2PFA99 | 100 |
| S/C | | C2RFA99 | 100 |
| S/C | | C27FA99 | 100 |
| S/C | | C2JFA99 | 100 |



| | | | |
|------------|--|---------|-----|
| F/S | | C2PED99 | 100 |
| F/S | | C2RED99 | 100 |
| S/C | | C2PFD99 | 100 |
| S/C | | C2RFD99 | 100 |
| S/C | | C27FD99 | 100 |
| S/C | | C2JFD99 | 100 |



| | | | |
|------------|--|---------|-----|
| F/S | | C2PEG99 | 100 |
| F/S | | C2REG99 | 100 |
| S/C | | C2PFG99 | 100 |
| S/C | | C2RFG99 | 100 |
| S/C | | C27FG99 | 100 |
| S/C | | C2JFG99 | 100 |

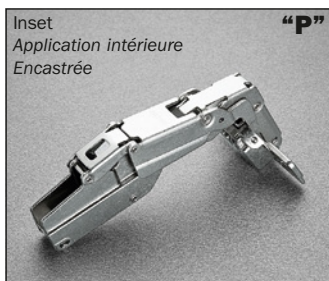

| | | | |
|------------|--|---------|-----|
| F/S | | C2PEP99 | 100 |
| F/S | | C2REP99 | 100 |
| S/C | | C2PFP99 | 100 |
| S/C | | C2RFP99 | 100 |
| S/C | | C27FP99 | 100 |
| S/C | | C2JFP99 | 100 |

3/8" lip door application Inset hinge - crank "P"

3/8" application avec portes moulurées Charnière application encastrée - bras "P"

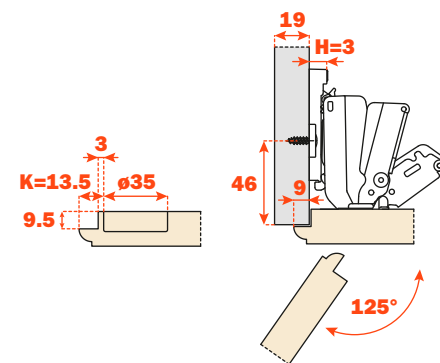

Greater drilling distance can be used to achieve large overlays with the use of reduction clips (see pag. 59).

Une plus grande distance de perçage peut être utilisée pour réaliser des recouvrements plus importantes avec l'utilisation de arrêts (voir page 59).

To limit hinge opening, please request the appropriate stops.

For a 125° reduction use item no. S2AF37X3

For a 110° reduction use item no. S2BF37XY.

Pour limiter l'ouverture de la charnière, veuillez demander les arrêts appropriés.

Pour limiter à 125° utiliser le code S2AF37X3.

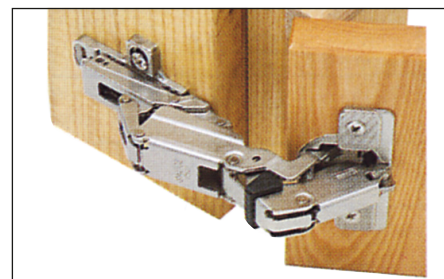

Pour limiter à 110° utiliser le code S2BF37XY.



200 series • For thicker doors - 155° • Special H Series, wide angle for the thickest door - up to a maximum of 35 mm
Série 200 • Pour portes épaisses - 155° • Série spéciale H, grand angle pour la porte la plus épaisse
• jusqu'à un maximum de 35 mm

S/C = Self-closing
 S/C = Avec ressort



| | | | |
|-----|---|---|------------------------|
| | | 155° Ø35 | Packaging Emballage |
| | |  | |
| S/C |  | C2PHA99 | 100 |
| S/C |  | C2RHA99 | 100 |

155° • Special applications • Applications spéciales

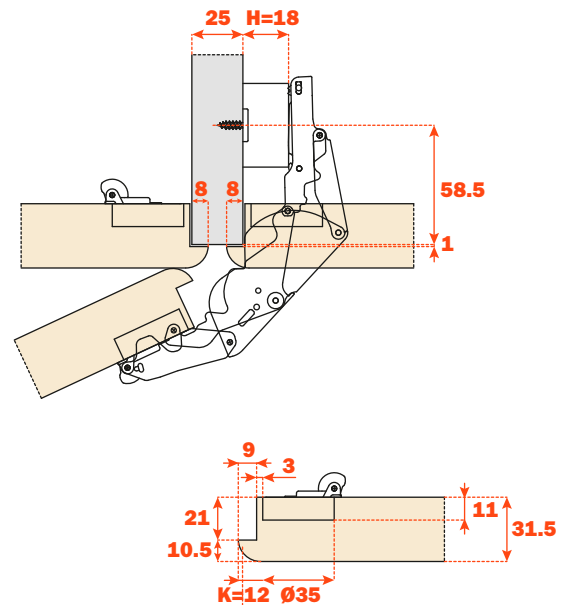
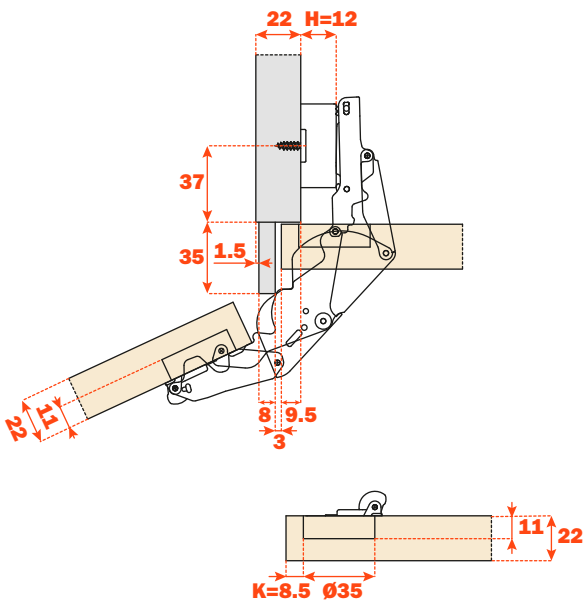
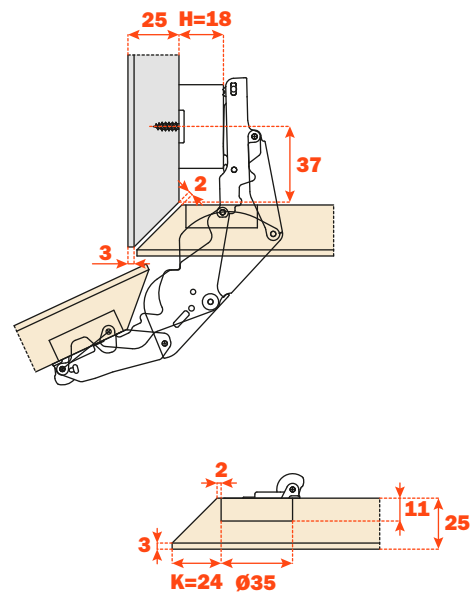
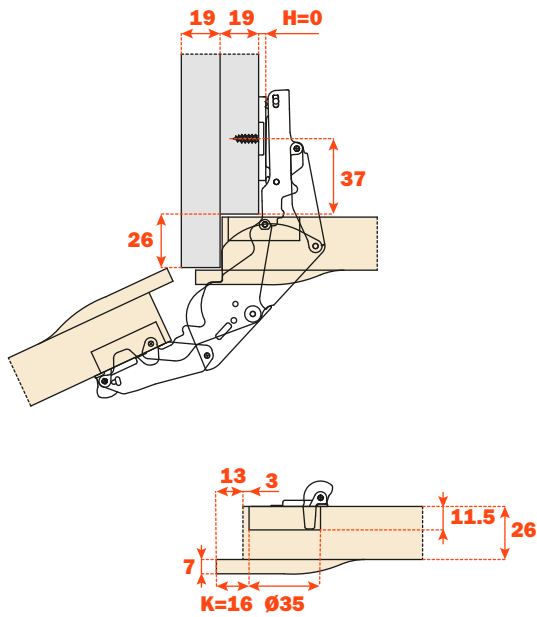

200 series • For thicker doors - 155° • Special H Series, wide angle for the thickest door
Série 200 • Pour portes épaisses - 155° • Série spéciale H, grand angle pour la porte la plus épaisse

155° • Thick door applications • Applications portes épaisses

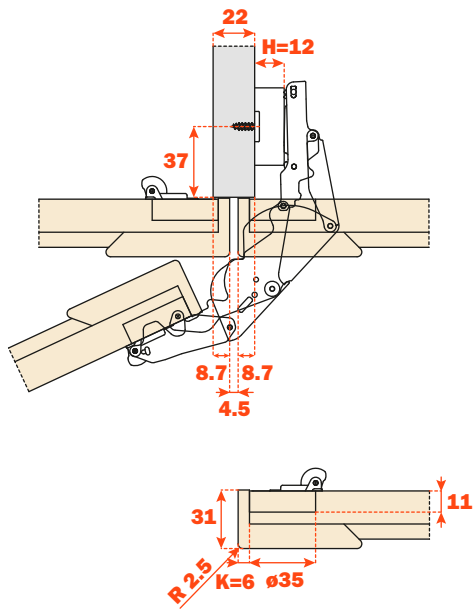

Zero protrusion 90° • Thick door applications
 Sans recul de la porte à 90° • Applications portes épaisses

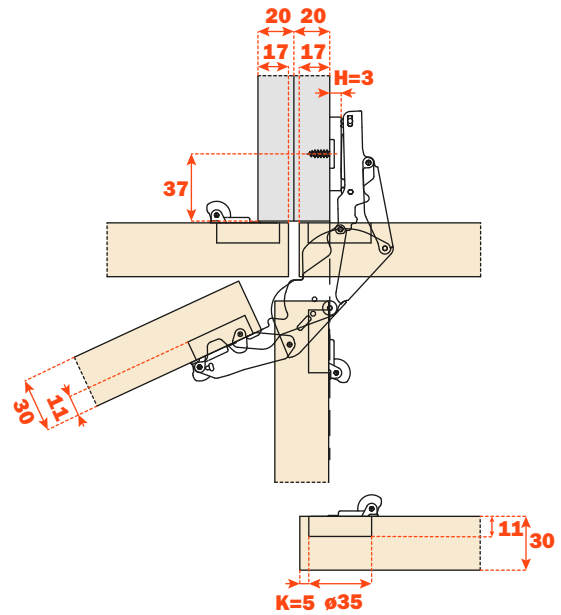



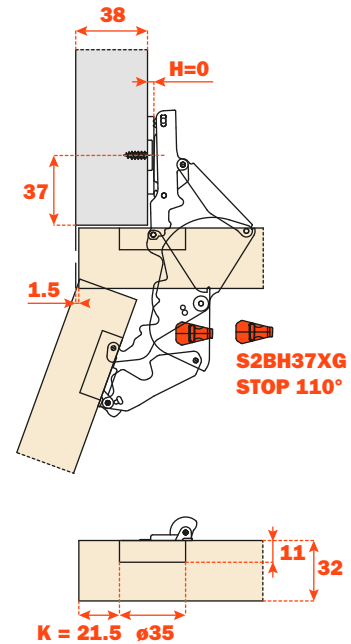
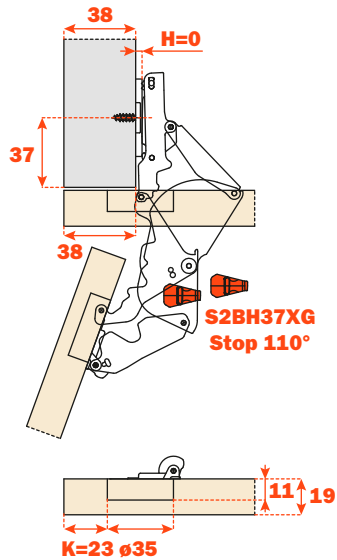

Thick panel overlay • with opening reduction device
 Recouvrement côtés épaisses • avec arrêts pour limiter l'ouverture





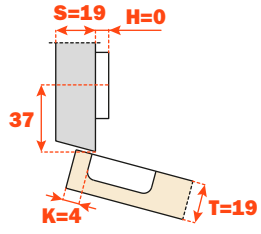

200 series • Special hinges for kitchen cabinets and furniture - positive angle hinges
Série 200 • Charnières spéciales pour meubles de cuisine et armoires - angle positif

| | | |
|--|---|------------------------|
| | 94° ø35 | Packaging Emballage |
| |  | |



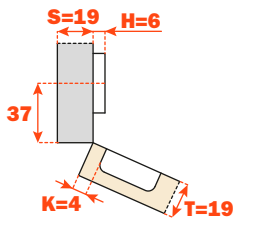



| | | | | |
|-----|---|---------|-----|--|
| S/C |  | C2PBZ99 | 150 |  <p>K = 3 to 9 K = de 3 à 9</p> |
| S/C |  | C2RBZ99 | 150 | |
| S/C |  | C27BZ99 | 150 | |
| S/C |  | C2JBZ99 | 150 | |



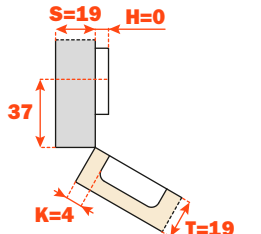



| | | | | |
|-----|--|---------|-----|---|
| S/C |  | C2PBU99 | 150 |  <p>K = 3 to 9 K = de 3 à 9</p> |
| S/C |  | C2RBU99 | 150 | |
| S/C |  | C27BU99 | 150 | |
| S/C |  | C2JBU99 | 150 | |



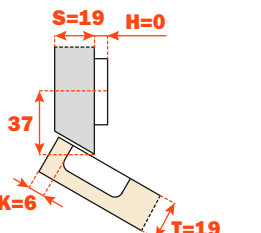



| | | | | |
|-----|---|---------|-----|--|
| S/C |  | C2PBE99 | 150 |  <p>K = 3 to 9 K = de 3 à 9</p> |
| S/C |  | C2RBE99 | 150 | |
| S/C |  | C27BE99 | 150 | |
| S/C |  | C2JBE99 | 150 | |

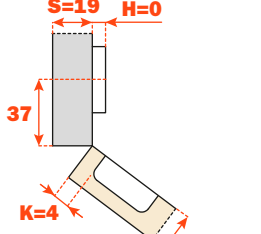

| | | | | |
|-----|---|---------|-----|--|
| S/C |  | C2PBT99 | 150 |  <p>K = 3 to 9 K = de 3 à 9</p> |
| S/C |  | C2RBT99 | 150 | |
| S/C |  | C27BT99 | 150 | |
| S/C |  | C2JBT99 | 150 | |



| | | | | |
|-----|---|---------|-----|--|
| S/C |  | C2PBK99 | 150 |  <p>K = 3 to 9 K = de 3 à 9</p> |
| S/C |  | C2RBK99 | 150 | |
| S/C |  | C27BK99 | 150 | |
| S/C |  | C2JBK99 | 150 | |

200 Series • Special hinges for kitchen cabinets and furniture - positive angle hinges Série 200 • Charnières spéciales pour meubles de cuisine et armoires - angle positif

| | | |
|--|---------|------------------------|
| | 94° ø35 | Packaging Emballage |
| | | |



| | | | |
|-----|--|-----------|-----|
| S/C | | C2PBM99AC | 150 |
| S/C | | C2RBM99AC | 150 |
| S/C | | C27BM99AC | 150 |
| S/C | | C2JBM99AC | 150 |

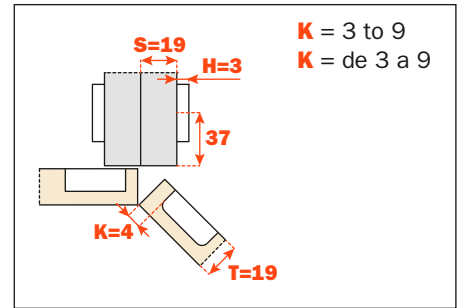

| | | | |
|-----|--|---------|-----|
| S/C | | C2PBM99 | 150 |
| S/C | | C2RBM99 | 150 |
| S/C | | C27BM99 | 150 |
| S/C | | C2JBM99 | 150 |

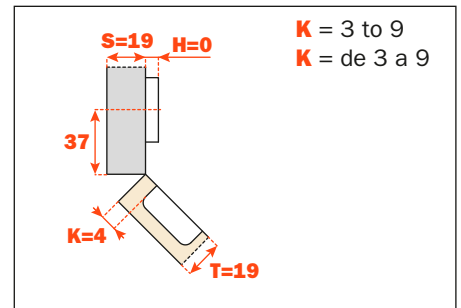

| | | | |
|-----|--|---------|-----|
| S/C | | C2PBV99 | 150 |
| S/C | | C2RBV99 | 150 |
| S/C | | C27BV99 | 150 |
| S/C | | C2JBV99 | 150 |

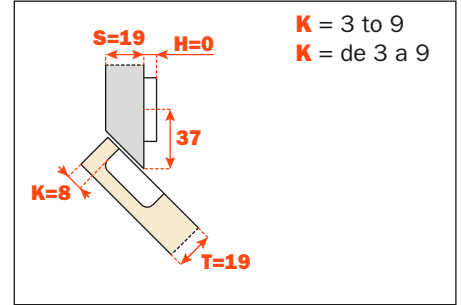

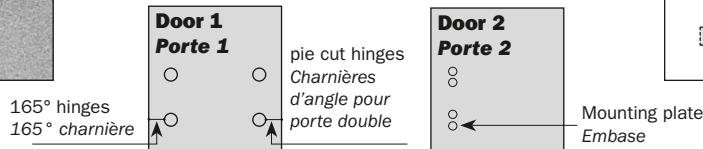
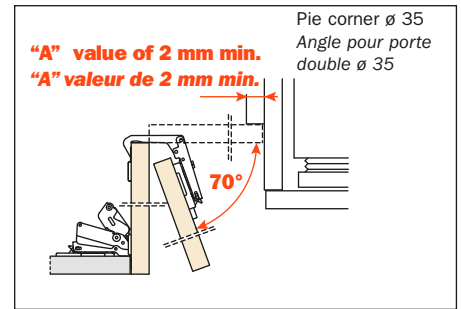

| | | | |
|-----|--|---------|-----|
| S/C | | C2PYA99 | 150 |
| S/C | | C2RYA99 | 150 |
| S/C | | C27YA99 | 150 |



Pie Corner hinge installation: Selecting & positioning the mounting plate • Installation de la charnière d'angle pour porte double: Sélection et positionnement de l'embase

| If Door thickness is: Si l'épaisseur de la porte est : (T) | Use mounting plate height Utiliser l'embase avec hauteur (H) | Mounting plate location Door edge to screw center Distance de perçage pour embase cruciforme (B) | Hinge cup edge bore distance Distance de perçage (K) |
|--|--|---|---|
| 16 mm (5/8") | 6 mm | 31 mm (1- 1/4") | 4 mm |
| 19 mm (3/4") | 2 mm or 3 mm | 28 mm (1- 1/8") | 4 mm |
| 22 mm (7/8") | 0 mm | 25 mm (1") | 4mm |

| | | |
|--|---|------------------------|
| | 94° ø35 | Packaging Emballage |
| |  | |

| | | | |
|------------|---|----------|-----|
| S/C |  | C2PYA99R | 150 |
| S/C |  | C2RYA99R | 150 |

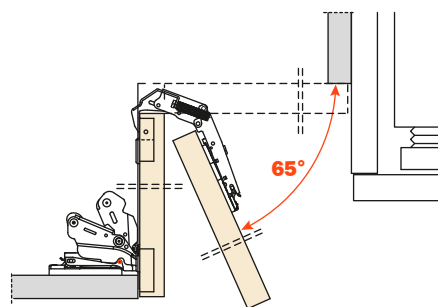

Using the hinge with a frame adapter plate 1 mm

Thickness of the door with square edges: min. 16 mm - max. 25 mm

Utilisation de la charnière avec un adaptateur de cadre 1 mm

Épaisseur de la porte à bord carré : min. 16 mm - max. 25 mm



Die-cast
Zamak

9.5x48 Screw-in. 3rd screw fixing option
9.5x48 A visser. Possibilité de fixation
par 3^{ème} vis

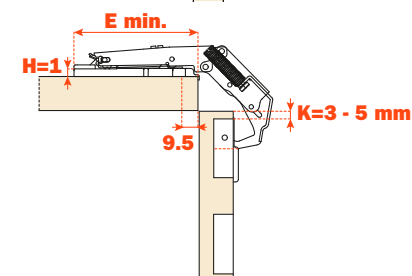
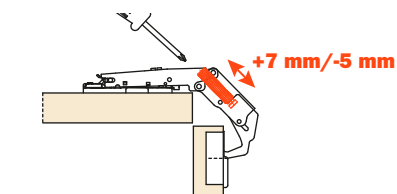
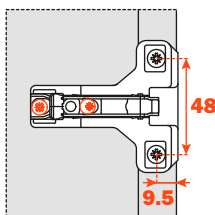
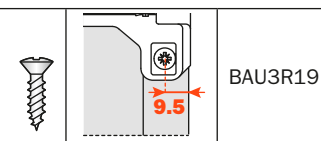

Using the hinge with a euro plate 0 mm

Thickness of the door with square edges: min. 16 mm - max. 25 mm

Utilisation de la charnière avec une embase euro 0 mm

Épaisseur de la porte à bord carré : min. 16 mm - max. 25 mm

Cruciform plate • Embase cruciforme

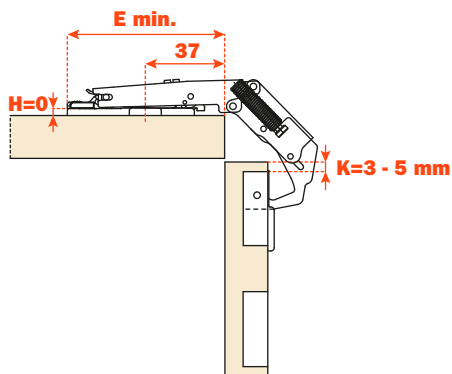

In-line plate • Embase longitudinale

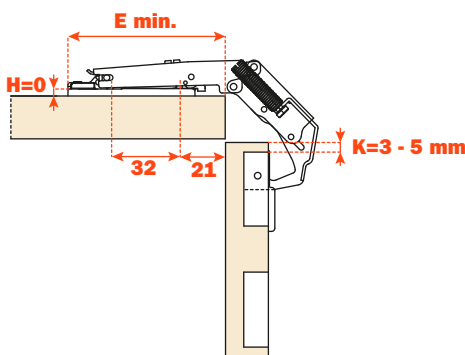

Using the hinge with a euro plate 3 mm

Thickness of the door with square edges: min. 19 mm - max. 25 mm

Utilisation de la charnière avec une embase euro 3 mm

Épaisseur de la porte à bord carré : min. 19 mm - max. 25 mm

Cruciform plate • Embase cruciforme

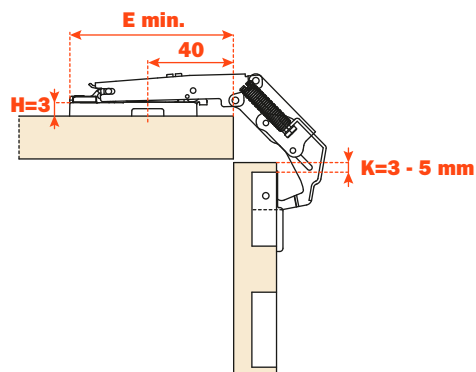

In-line plate • Embase longitudinale

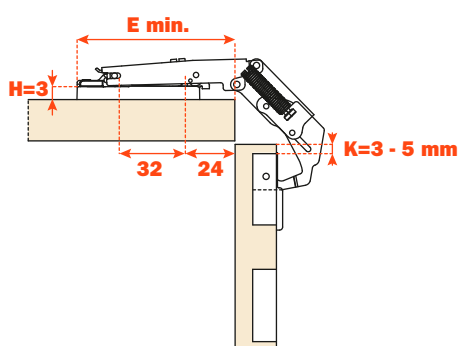

200 series • Special hinges for kitchen cabinets and furniture - negative angle hinges
Série 200 • Charnières spéciales pour meubles de cuisine et armoires - angle négatif

| | | |
|--|---|------------------------|
| | 120° ø 35 | Packaging Emballage |
| |  | |

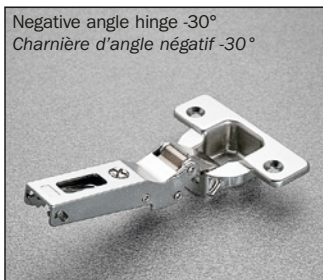

| | | | |
|-----|--|---------|-----|
| S/C | | C2PBW99 | 150 |
| S/C | | C2RBW99 | 150 |
| S/C | | C27BW99 | 150 |
| S/C | | C2JBW99 | 150 |
| | | | |
| | | | |

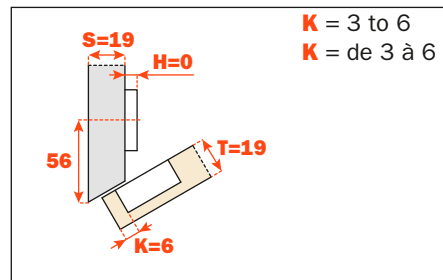

| | | | |
|-----|--|---------|-----|
| S/C | | C2PBH99 | 150 |
| S/C | | C2RBH99 | 150 |
| S/C | | C27BH99 | 150 |
| S/C | | C2JBH99 | 150 |
| | | | |
| | | | |

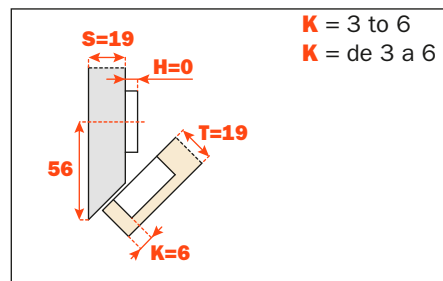



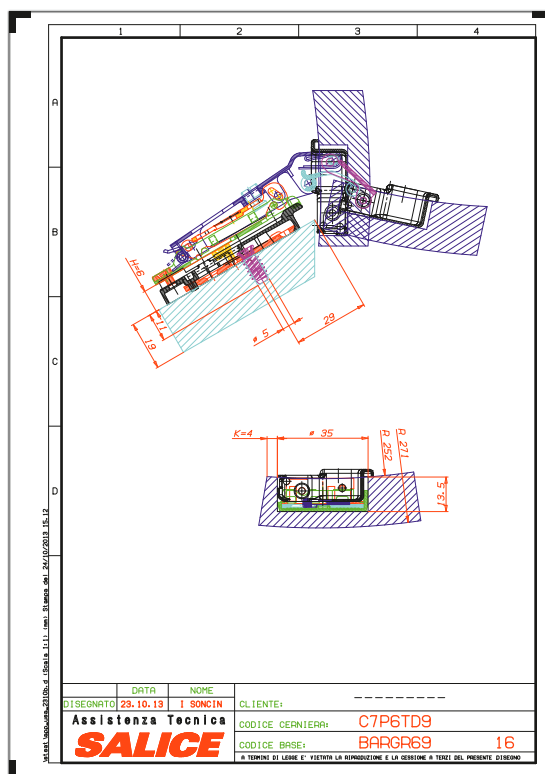
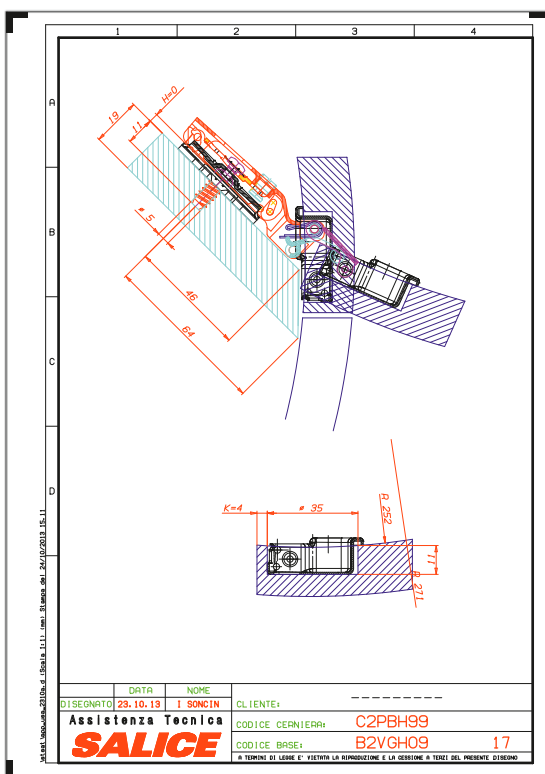



Custom CAD drawings are available for cabinet designs which feature special angles, curves and other unique design elements.
 Les dessins CAD personnalisés sont disponibles pour les projets de meubles avec angles spéciaux, courbes et autres éléments de conception uniques.

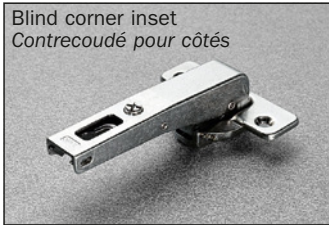

200 Series • Special hinges for kitchen cabinets and furniture - blind corner hinges

Série 200 • Charnières spéciales pour meubles de cuisine et armoires - contrecoudé pour côtés



| | | 94° ø35 | Packaging Emballage |
|------------|---|---|------------------------|
| | |  | |
| S/C |  | C2PBN99AC | 150 |
| S/C |  | C2RBN99AC | 150 |
| S/C |  | C27BN99AC | 150 |
| S/C |  | C2JBN99AC | 150 |

Blind corner ø 35
Mounting plate: H = 2 or 3

Contrecoudé pour côtés ø 35
Embase : H = 2 ou 3

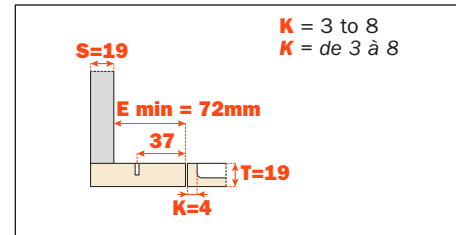



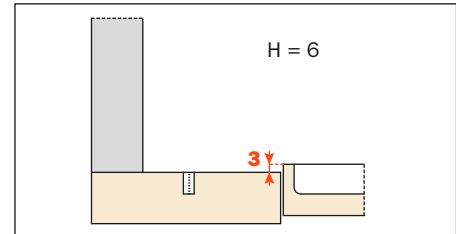
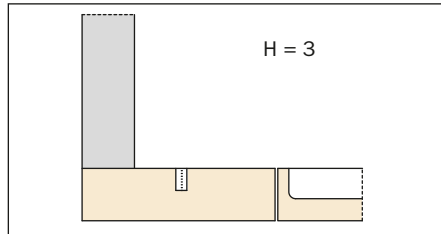
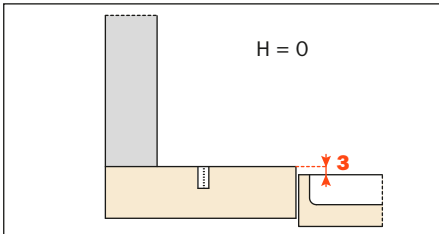

Heights of mounting plates for every assembly. Hauteurs des embases pour chaque montage.



IMPORTANT: If door and panel are the same thickness ($\frac{3}{4}$ " S with $\frac{3}{4}$ " T or $\frac{5}{8}$ " S with $\frac{5}{8}$ " T) the mounting plate choices remain the same.
IMPORTANT: si la porte et le côté ont la même épaisseur ($\frac{3}{4}$ " S avec $\frac{3}{4}$ " T ou $\frac{5}{8}$ " S avec $\frac{5}{8}$ " T), les choix de l'embase restent les mêmes.



| | | | |
|------------|---|---------|-----|
| S/C |  | C2PBN99 | 150 |
| S/C |  | C2RBN99 | 150 |
| S/C |  | C27BN99 | 150 |
| S/C |  | C2JBN99 | 150 |

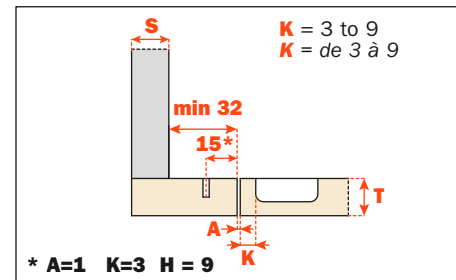

B2S3B99B6/15



Blind corner ø 35
Compatible with all traditional Series 200 mounting plates,
28x32 mm drilling.
NOT COMPATIBLE with Domi snap-on mounting plates.

Contrecoudé ø 35
Adaptables à toutes les embases traditionnelles Série 200, perçage
28x32 mm.
NON ADAPTABLES aux embases Domi à fixation rapide.

| | | 110° ø35 | Packaging Emballage |
|--|--|---|------------------------|
| | |  | |

Blind corner overlay ø 35
Mounting plate: H = 2 or 3

Contrecoudé long ø 35
Embase: H = 2 ou 3



| | | | |
|------------|---|-----------|-----|
| S/C |  | C2P6N99AM | 150 |
| S/C |  | C2R6N99AM | 150 |
| S/C |  | C276N99AM | 150 |
| S/C |  | C2J6N99AM | 150 |

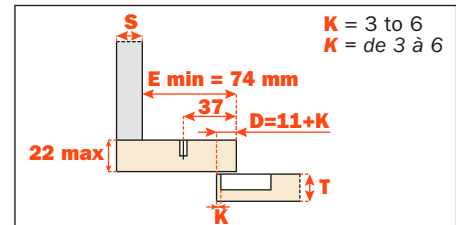

Mounting plate heights for every assembly. Hauteurs des embases pour chaque montage.

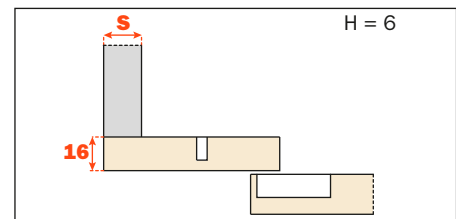
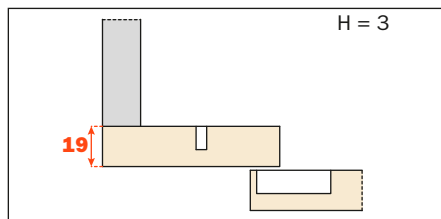
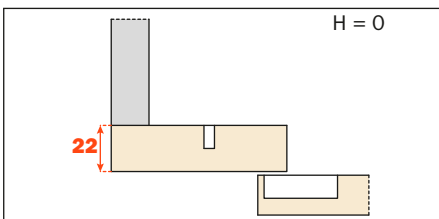







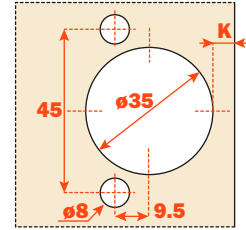

200 Series • For thicker doors - 94° Série 200 • Pour portes épaisses - 94°

S/C = Self-closing
S/C = Avec ressort

F/S = Free swing
F/S = Sans ressort

| | | |
|--|---|-----------------------|
| | 94° ø35 | Packaging Embalaje |
| |  | |





| | | | | | |
|--|---|------------|--|---------|-----|
| Full overlay <i>Plain recouvrement</i> <i>Porte en applique</i> |  | "A" | F/S  | C2PAA99 | 300 |
| | | | F/S  | C2RAA99 | 300 |
| | | | S/C  | C2PBA99 | 300 |
| | | | S/C  | C2RBA99 | 300 |
| | | | S/C  | C27BA99 | 300 |
| | | | S/C  | C2JBA99 | 300 |

For thick doors up to 32 mm (1- 1/4") 11 mm deep metal cup, possible drilling distance on the door (K); from 3 to 9 mm

For full overlay doors up to 1- 1/4" thick, choose one of the following solutions, K=8







Arm "A" + 6 mm plate + adjustment
- or -
Arm "D" + 0 mm plate + adjustment

| | | | | | |
|---|--|------------|--|---------|-----|
| 1/2" Overlay - Face frame <i>Face frame à encadrement</i> |  | "D" | S/C  | C2PBD99 | 300 |
| | | | S/C  | C2RBD99 | 300 |
| | | | | | |
| | | | | | |
| | | | | | |

Pour les portes d'épaisseur jusqu'à 32 mm (1- 1/4"), profondeur du boîtier métallique 11 mm. Possibilité de perçage de la porte (K) de 3 à 9 mm.

Pour les portes en applique jusqu'à 1- 1/4" d'épaisseur, choisir une des options suivantes, K=8





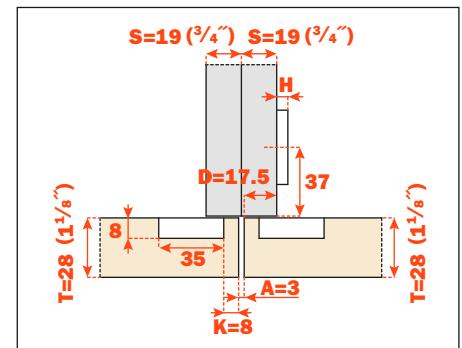

Bras "A" + embase 6 mm + réglage
- ou -
Bras "D" + embase 0 mm + réglage

| | | | | | |
|---|---|------------|--|---------|-----|
| Half overlay <i>Demi recouvrement</i> <i>Portes jumelées</i> |  | "G" | F/S  | C2PAG99 | 300 |
| | | | F/S  | C2RAG99 | 300 |
| | | | S/C  | C2PBG99 | 300 |
| | | | S/C  | C2RBG99 | 300 |
| | | | S/C  | C27BG99 | 300 |
| | | | S/C  | C2JBG99 | 300 |



For inset doors:
Arm "P" + 9 mm plate + adjustment Up to 1- 1/4" thick. K=8

Pour portes avec application intérieure/ encastrée :
Bras "P" + embase 9 mm + réglage jusqu'à 1- 1/4" d'épaisseur K=8

| | | | | | |
|---|---|------------|--|---------|-----|
| Inset <i>Application intérieure</i> <i>Encastrée</i> |  | "P" | F/S  | C2PAP99 | 300 |
| | | | F/S  | C2RAP99 | 300 |
| | | | S/C  | C2PBP99 | 300 |
| | | | S/C  | C2RBP99 | 300 |
| | | | S/C  | C27BP99 | 300 |
| | | | S/C  | C2JBP99 | 300 |

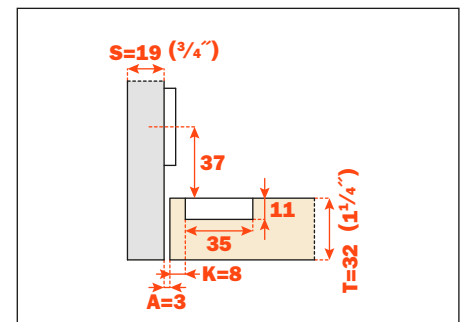

S2A637XF 86° Reduction clip.

The reduction in the opening prevents the collision of doors against walls and other obstacles. (see pag 59)

S2A637XF Arrêt à 86°.



La limitation de l'ouverture évite toutes les interférences des portes contre les murs et autres obstacles (voir page 59).

200 series • For thicker doors - 155° • K Series, zero protrusion, wide angle
Série 200 • - Pour portes épaisses - 155° • Série K, sans recul de la porte, grand angle

S/C = Self-closing
 S/C = Avec ressort

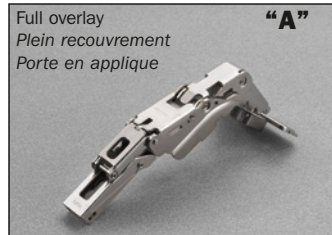
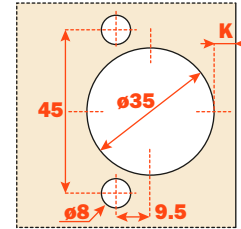
| | | |
|--|---|------------------------|
| | 155° ø35 | Packaging Emballage |
| |  | |





| | | | |
|-----|---|---------|-----|
| S/C |  | C2PKA99 | 100 |
| S/C |  | C2RKA99 | 100 |
| | | | |
| | | | |
| | | | |

For pull out shelf application, total door clearance (zero protrusion) begins at 90° opening.
 Full overlay (19 mm - 3/4") application only. 0 mm to 6 mm plates only.

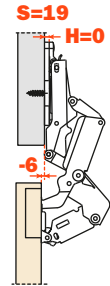
Pour des espaces avec éléments extractibles.
 Avec une ouverture à 90° et une embases H=0, la porte dégage de 6 mm.



| | | | |
|-----|---|---------|-----|
| S/C |  | C2PKD99 | 100 |
| S/C |  | C2RKD99 | 100 |
| | | | |
| | | | |
| | | | |

For thick doors up to 28 mm (1- 1/8") 8 mm deep metal cup, possible drilling distance on the door (K); from 3 to 9 mm

For full overlay doors up to 1- 1/8" thick, choose one of the following solutions, K=8



Arm "A" + 6 mm plate + adjustment
 - or -
 Arm "D" + 0 mm plate + adjustment

Pour les portes d'épaisseur jusqu'à 28 mm (1- 1/8"), profondeur du boîtier métallique 8 mm.
 Possibilité de perçage de la porte (K) de 3 à 9 mm.

Pour les portes en applique jusqu'à 1- 1/8" d'épaisseur, choisir une des options suivantes, K=8

Bras "A" + embase 6 mm + réglage
 - ou -
 Bras "D" + embase 0 mm + réglage



| | | | |
|-----|---|---------|-----|
| S/C |  | C2PKG99 | 100 |
| S/C |  | C2RKG99 | 100 |
| | | | |
| | | | |
| | | | |

S2BF37XY 110° Reduction clip
S2AF37X3 125° Reduction clip
 Reduction clip can be used to allow the increase of drilling distance and overlay. The reduction in the opening allows the turning of thicker doors. (see pag. 59)

S2BF37XY Arrêt à 110°
S2AF37X3 Arrêt à 125°
 L'arrêt peut être utilisé pour augmenter la distance de perçage et le recouvrement. La limitation de l'ouverture permet la rotation de portes plus épaisses (voir page 59).

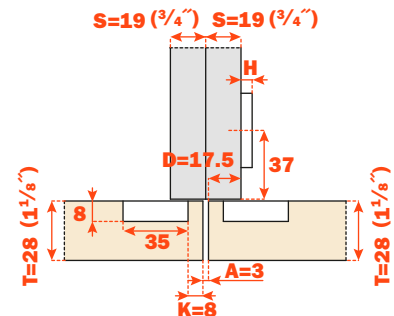



Series 300 • compact hinge for special applications Série 300 • charnière compacte pour applications spéciales

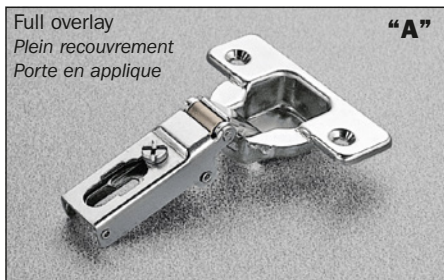

S/C = Self-closing
S/C = Avec ressort

| | | |
|--|---|------------------------|
| | 94° Ø35 | Packaging Emballage |
| |  | |

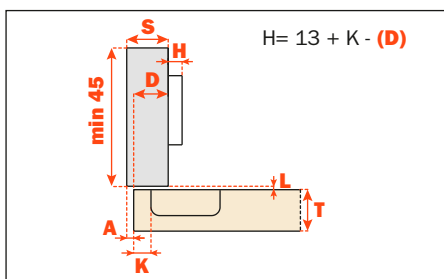
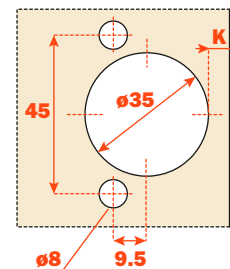

| | | | |
|-----|---|---------|-----|
| S/C |  | C3PBA99 | 300 |
| S/C |  | C3RBA99 | 300 |
| | | | |
| | | | |
| | | | |
| | | | |



| | | | |
|--|---|---|------------------------|
| | <p>0mm Side panel 3/4" Full overlay</p> <p>Côté 3/4" Porte en applique</p>  | <p>6mm 1/2" overlay Partial overlay</p> <p>Côté 1/2" Face frame à encadrement</p>  | Packaging Emballage |
|--|---|---|------------------------|

| | | | | |
|---------------------|--|---------|---------|-----|
| | Series 300 - mounting plates - drilling 20x32 Série 300 - embases - perçage 20x32 | | | |
| Die-cast - Zamak |  | B383E09 | B383E69 | 600 |

S38X8639



Spacers

3 mm spacer for special applications

Supports

Support pour l'embase hauteur 3 mm pour applications spéciales

Packaging - Emballage
300

S38X86D9



Spacers

13 mm spacer for special applications

Supports

Support pour l'embase hauteur 13 mm pour applications spéciales

Packaging - Emballage
300



Series 800 • An affordable clip system
Série 800 • Un système de clips abordable

S/C = Self-closing
S/C = Avec ressort



F/S = Free Swinging
F/S = Sans ressort

| | | |
|--|---|------------------------|
| | 110° Ø35 | Packaging Emballage |
| |  | |



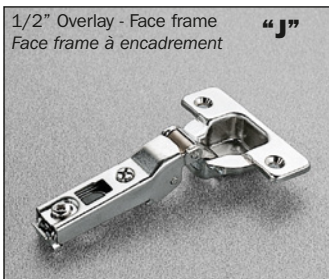
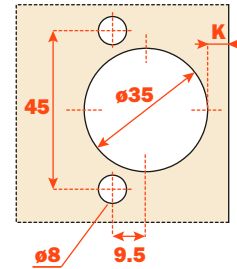

| | | | |
|------------|---|---------|-----|
| S/C |  | C8P6C99 | 300 |
| S/C |  | C8R6C99 | 300 |
| S/C |  | C876C99 | 300 |



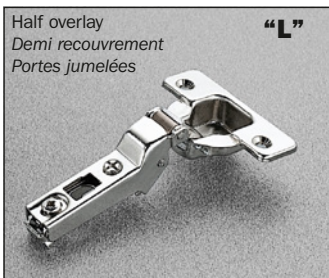

| | | | |
|------------|--|---------|-----|
| S/C |  | C8P6J99 | 300 |
| S/C |  | C8R6J99 | 300 |
| S/C |  | C876J99 | 300 |



| | | | |
|------------|---|---------|-----|
| S/C |  | C8P6L99 | 300 |
| S/C |  | C8R6L99 | 300 |
| S/C |  | C876L99 | 300 |



| | | | |
|------------|---|---------|-----|
| S/C |  | C8P6S99 | 300 |
| S/C |  | C8R6S99 | 300 |
| S/C |  | C876S99 | 300 |

To be assembled (clip) on B2VXH plates exclusively (I.E. B2V3H09/15)

Montage (automatique) exclusivement avec l'embase B2VXH
(EX. B2V3H09/15)

Universal hinges • Hinges with integrated silicone-oil damper for doors with special profiles Charnières Universelles • Charnières avec amortisseur hydraulique intégré, pour portes moulurées

Cup depth 9 mm, opening 110° K = 3 to 18 mm (on square edge doors).

Profondeur du boîtier 9 mm, ouverture à 110°, K de 3 à 18 mm (pour portes carrées).

| | | |
|----------|--|------------------------|
| 110° ø35 | | Packaging Emballage |
| |  | |



| | | |
|---------|---|-----|
| CBP2AE9 | with integrated soft-close • avec amortisseur intégré | 150 |
| CBP2AC9 | sprung hinge • charnière avec ressort | 150 |
| CBPQAC9 | with Push opening • avec ouverture Push | 150 |
| CBP1AC9 | free swing hinge • charnière sans ressort | 150 |

SBAX78A6SN



Hollow cover

Cache

SBXX85X_

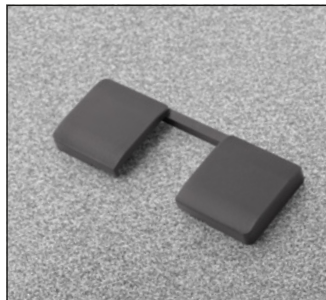

Flange cover cap

Plastic flange cover cap

Cache pour boîtier.
Cache-boîtier en nylon.

Available colors:
Couleurs disponibles:

SBXX85X9 = Nickel-plated
nickelé mat

SBXX85X6 = Titanium
Titane

DBDESNG



Smove, Soft-close device

Smove

SBA237XG

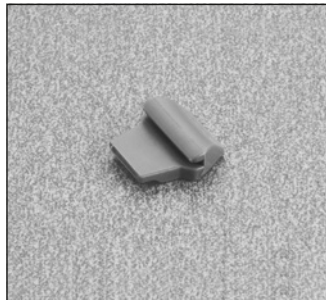

Stop device

It limits the opening angle to 90°

Arrêt

Pour limiter l'ouverture à 90°



Universal hinges • Disassembly and assembly instructions Charnières Universelles • Instructions de démontage et montage

Disassembly of the Smove.

It is possible to convert the hinges with integrated soft-close into sprung hinges by replacing the Smove with the hollow cover.

Démontage du Smove.

Possibilité de convertir les charnières avec amortisseur intégré en charnières avec ressort en remplaçant le Smove par le cache.

Lift the Smove using a flat-blade screwdriver.
Soulever le Smove avec un tournevis plat.

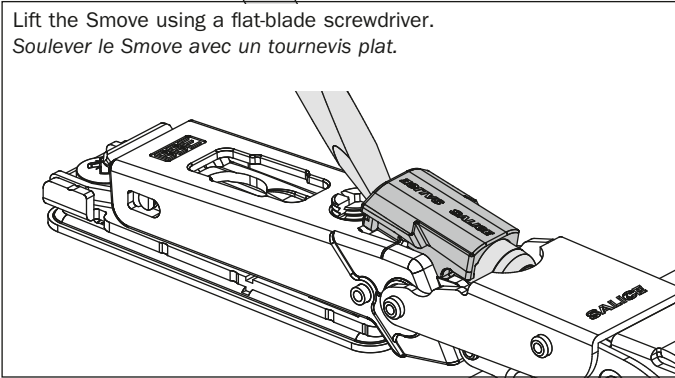

Remove the Smove from the hinge arm.
Enlever le Smove.

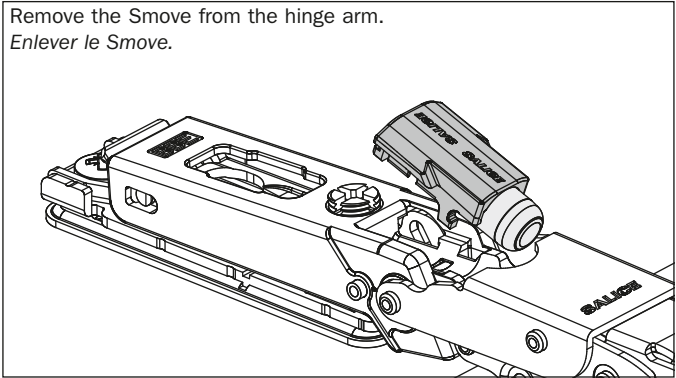

Insert the hollow cover frontally.
Insérer le cache frontalement.

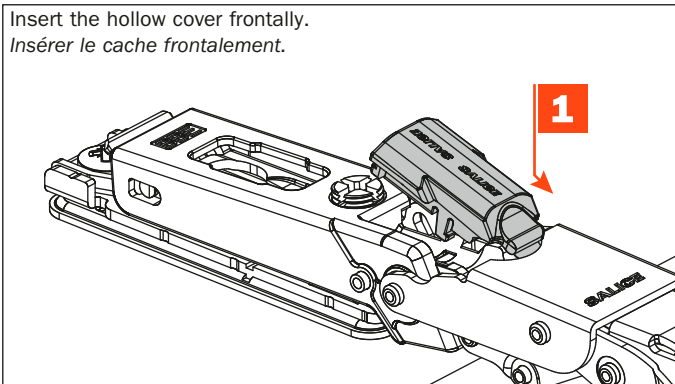

Press lightly on the back to fix in position.
Appuyer légèrement sur l'extrémité arrière.

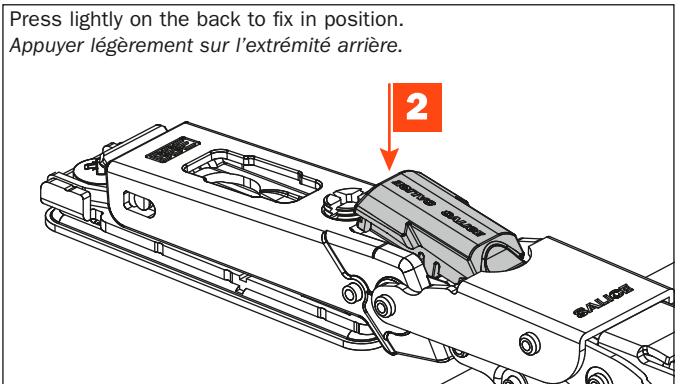

Disassembly of the hollow cover.

It is possible to convert the sprung hinges into hinges with integrated soft-close by replacing the hollow cover with the Smove.

Démontage du cache.

Possibilité de convertir les charnières avec ressort en charnières avec amortisseur intégré en remplaçant le cache par le Smove.

Lift the hollow cover using a flat-blade screwdriver.
Soulever le cache avec un tournevis plat.

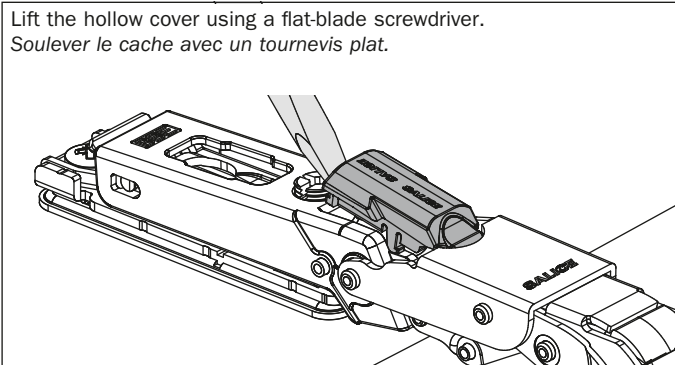

Remove the hollow cover.
Enlever le cache.

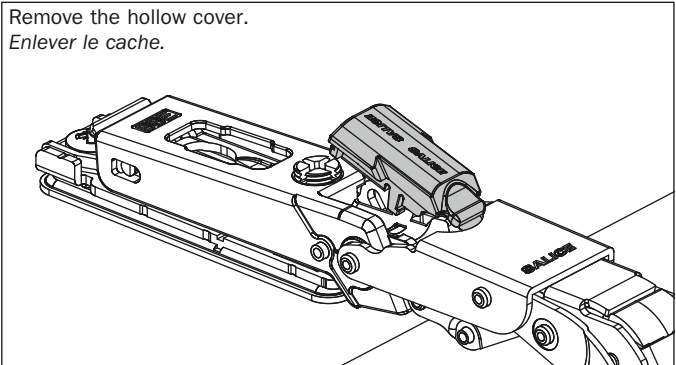

Insert the Smove frontally.
Insérer le Smove frontalement.

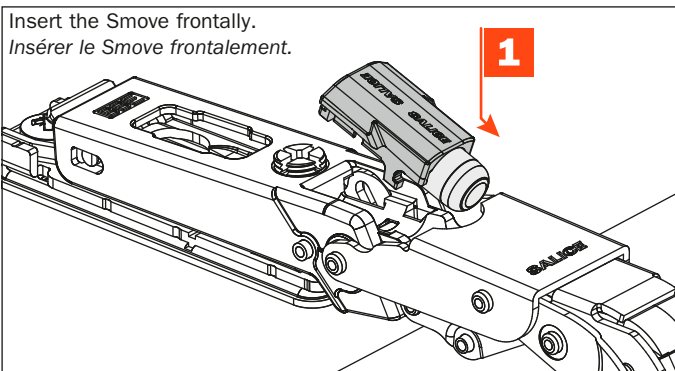

Press lightly on the back to fix in position.
Appuyer légèrement sur l'extrémité arrière.

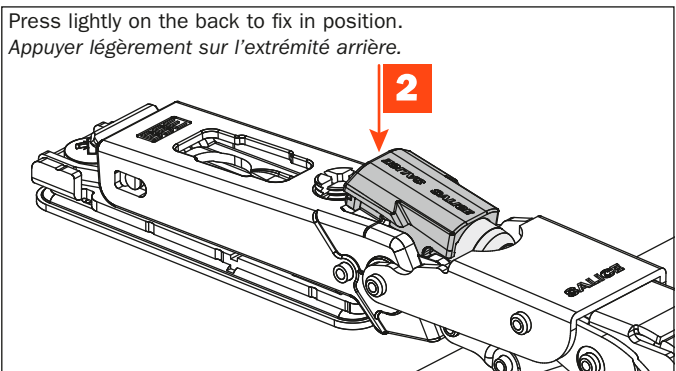

Universal hinges Charnières Universelles

Abbreviations chart - Abréviations:

S = thickness of the cabinet side
épaisseur du côté

D = required door overlay
recouvrement désiré

T = max. door thickness
épaisseur max. de la porte

K = drilling distance
distance de perçage

A = reveal
jeu

L = gap between door and carcass
distance entre la porte et le côté

H = height of the mounting plate
hauteur de l'embase

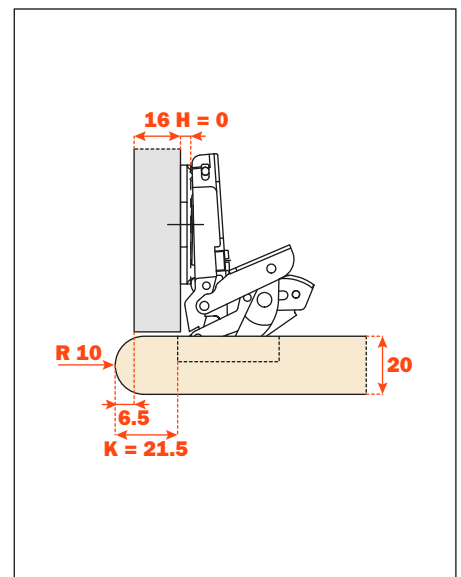
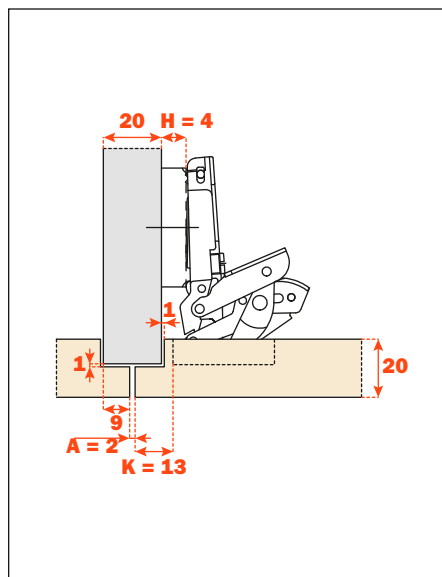
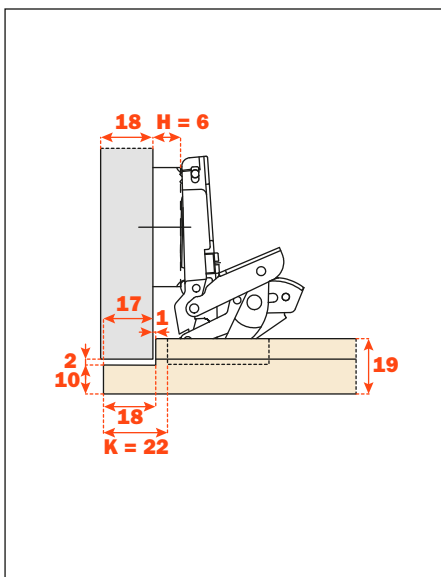
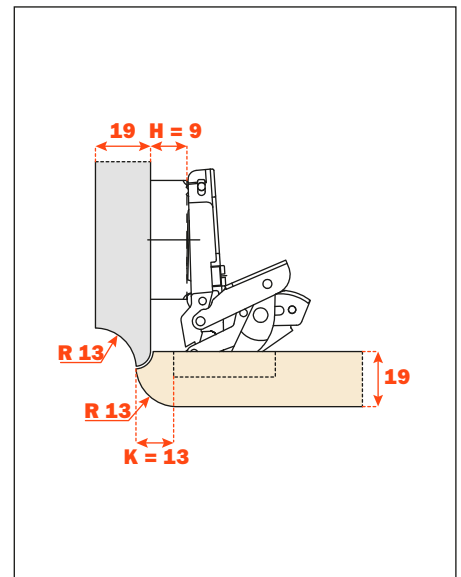
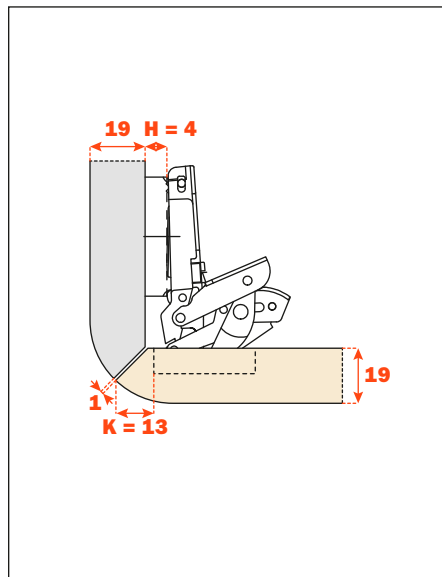
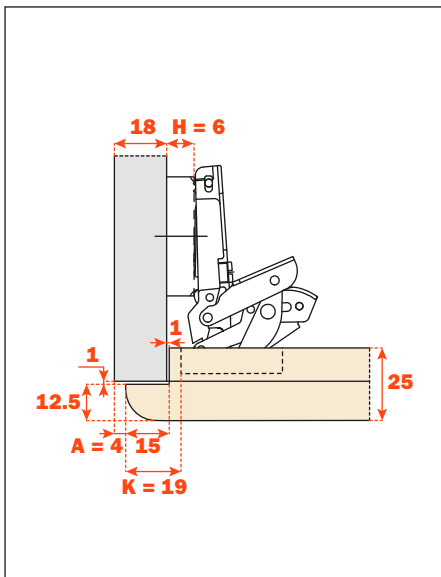
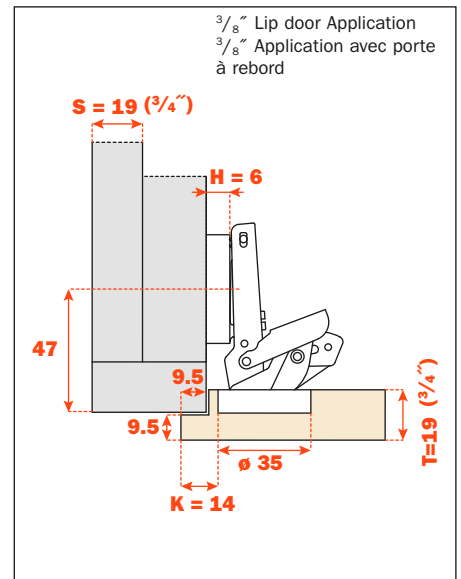

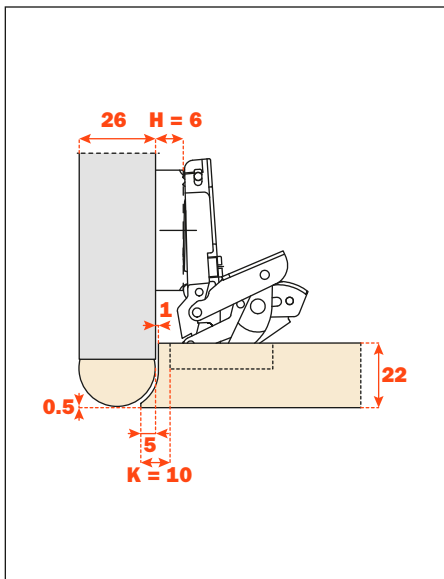
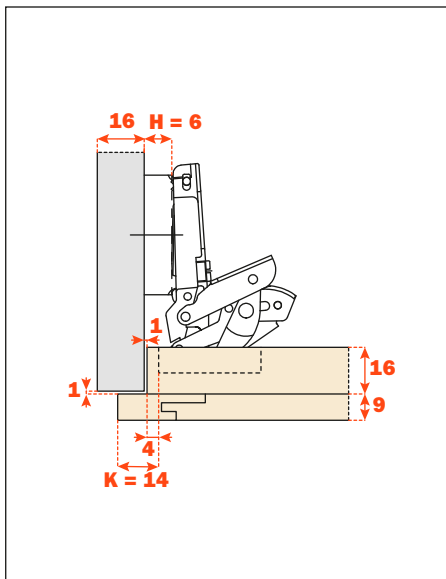
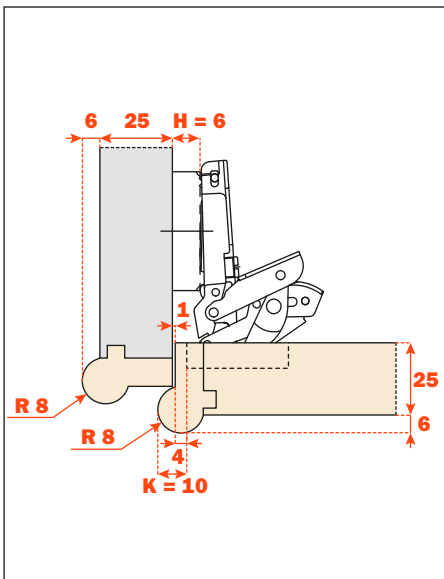
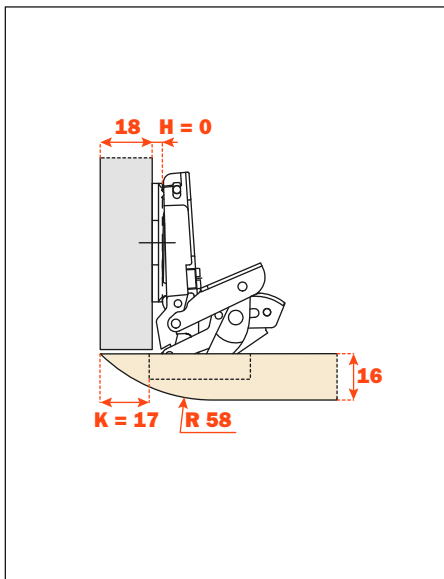
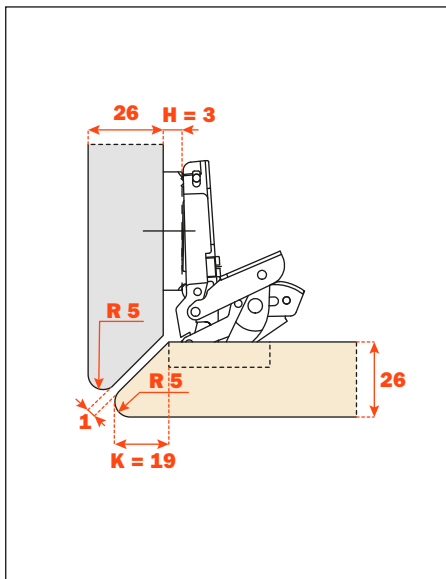
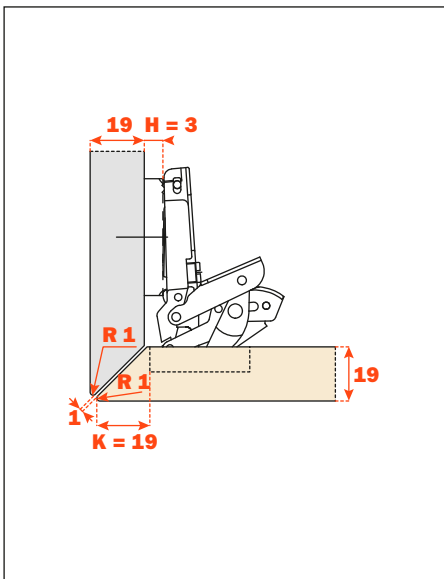

Single pivot hinge • 270° opening
Charnière à un axe • Ouverture à 270°

| | |
|--|--------------|
| | |
| Wood screw Vis à bois CMP3A99 | P |
| | |
| Dowel Tourillon CMR3A99 | R |



Single pivot hinges.
270° opening angle.
Bright nickel plated die-cast cup and arm.
Integrated stay close feature.

Ideal for the most critical applications, where high stability, strength and endurance are required. They are certified for applications in public environments in conformity with FIRA Level 5 and ANSI Grade 1 requirements.

Adjustments.

Side adjustment +3 mm to -3 mm with 3 mm mounting plate, +3 mm to -1 mm with 2 mm mounting plate and +3 mm to -0 mm with a 0 mm mounting plate.
 Height adjustment ± 2 mm.
 Depth adjustment with 200 series traditional mounting plates +2.8 mm.
 Depth adjustment with Domi snap-on mounting plates from -0.5 mm to +2.8 mm.
 Anti-sliding safety stop when using traditional plate.

Mounting plates.

Symmetrical and asymmetrical bright nickel plated steel or die-cast 200 series mounting plates.
 Snap-on assembly on Domi mounting plates.
 Positioning with pre-determined stop on traditional 200 series mounting plates.

IMPORTANT : Use POZIDRIVE No. 2 screwdrivers for all screws.

Charnières à un axe.
Angle d'ouverture à 270°.
Bras et boîtier en zamak nickelé mat.
Fermeture automatique (avec ressort).

Idéales pour les applications les plus difficiles, qui nécessitent une grande stabilité et une résistance dans le temps. Certifiées pour les applications dans les environnements publics selon les normes FIRA Niveau 5 et ANSI Degré 1.

Réglages.

Réglage latéral compensé de -3 mm à +3 mm avec embase H=3, de +3 mm à -1 mm avec embase H=2 mm et de +3 mm à -0 mm avec embase H=0 mm.
 Réglage vertical ± 2 mm.
 Réglage frontal avec embases Série 200 +2.8 mm.
 Réglage frontal avec embases Domi de -0.5 mm à +2.8 mm.
 Dispositif d'arrêt de sécurité.

Embases.

Embases symétriques et asymétriques en acier ou en zamak nickelé mat de la Série 200.
 Fixation rapide sur embases Domi.
 Positionnement avec butée en fin de course sur embases traditionnelles de la Série 200.
N.B. : Utiliser le tournevis POZIDRIVE n° 2 pour toutes les vis.



Packaging - 100 · Emballages - 100

Use these formulas to determine the height of the mounting plate "H" which is necessary to solve each application problem.

Utiliser ces formules pour définir la hauteur de l'embase "H" nécessaire pour résoudre chaque problème d'application.

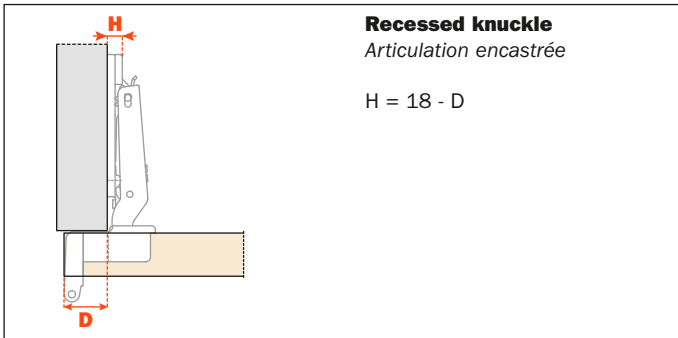

Recessed knuckle
Articulation encastrée

$H = 18 - D$

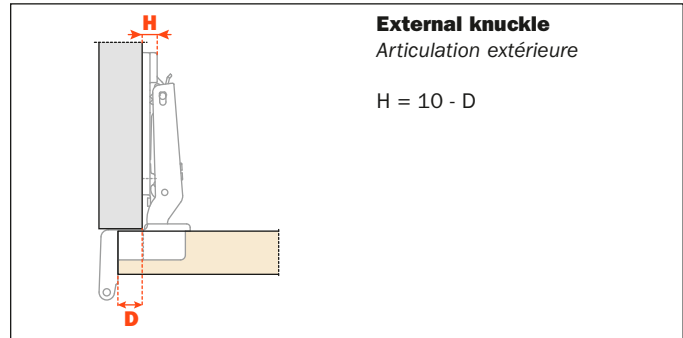

External knuckle
Articulation extérieure

$H = 10 - D$

Use the chart below to verify that full 270° opening is possible.

Full 270° opening is possible only with R value ≥ 0 and mounting plates H=0 mm. Otherwise the actual opening must be checked with a practical test.



Tableau pour la vérification de l'ouverture à 270°.

L'ouverture à 270° est possible seulement avec valeur $R \geq 0$ et embases H=0 mm. Dans le cas contraire, l'ouverture réelle doit être vérifiée par un test.

| | | Door thickness T Épaisseur de la porte T | | |
|---|----|---|------|------|
| | | 18 | 19 | 20 |
| Side thickness S Épaisseur du côté S | 20 | 2.25 | 1.25 | 0.25 |
| | 19 | 3.25 | 2.25 | 1.25 |
| | 18 | 4.25 | 3.25 | 2.25 |
| R value Valeur R | | | | |

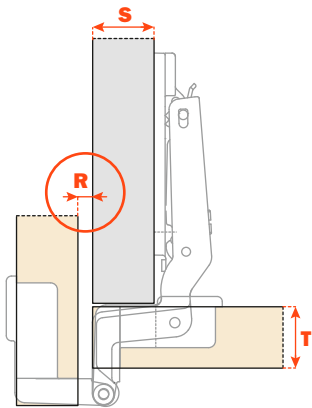
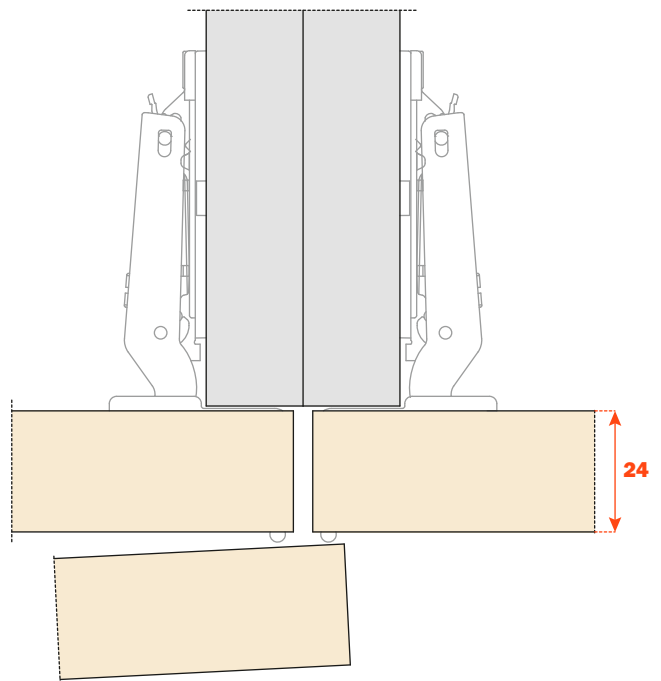

180° opening with door thickness max. 24 mm.

Ouverture à 180° avec portes d'épaisseur max. 24 mm.

Single pivot hinge • 270° opening
Charnière à un axe • Ouverture à 270°

Application with recessed knuckle
Application avec articulation encastrée

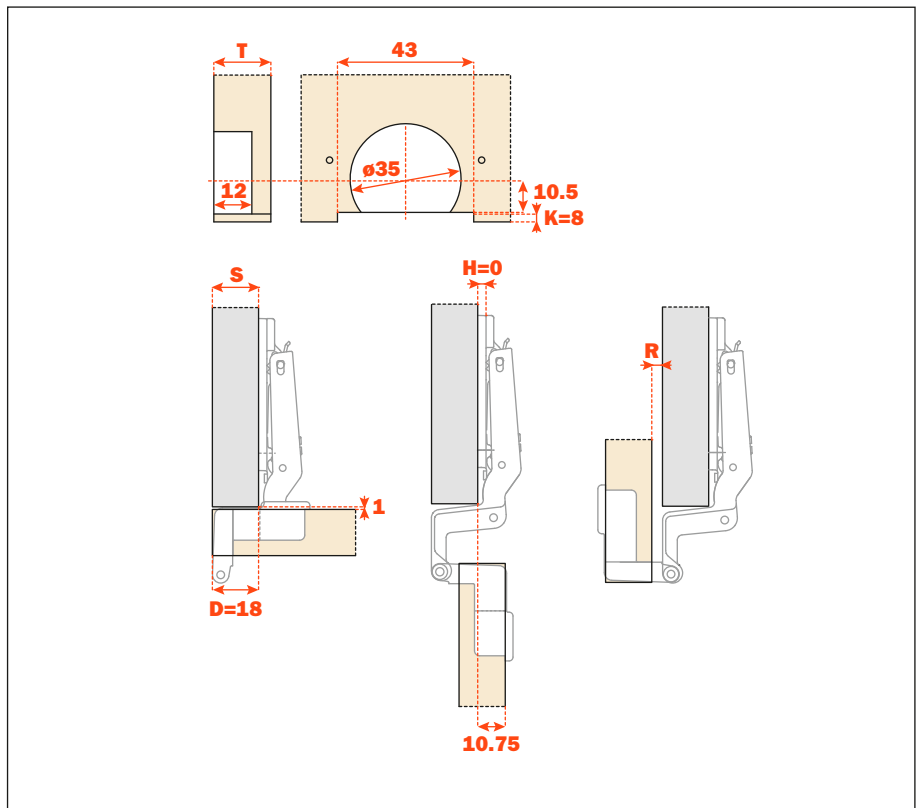

Application with external knuckle
Application avec articulation extérieure

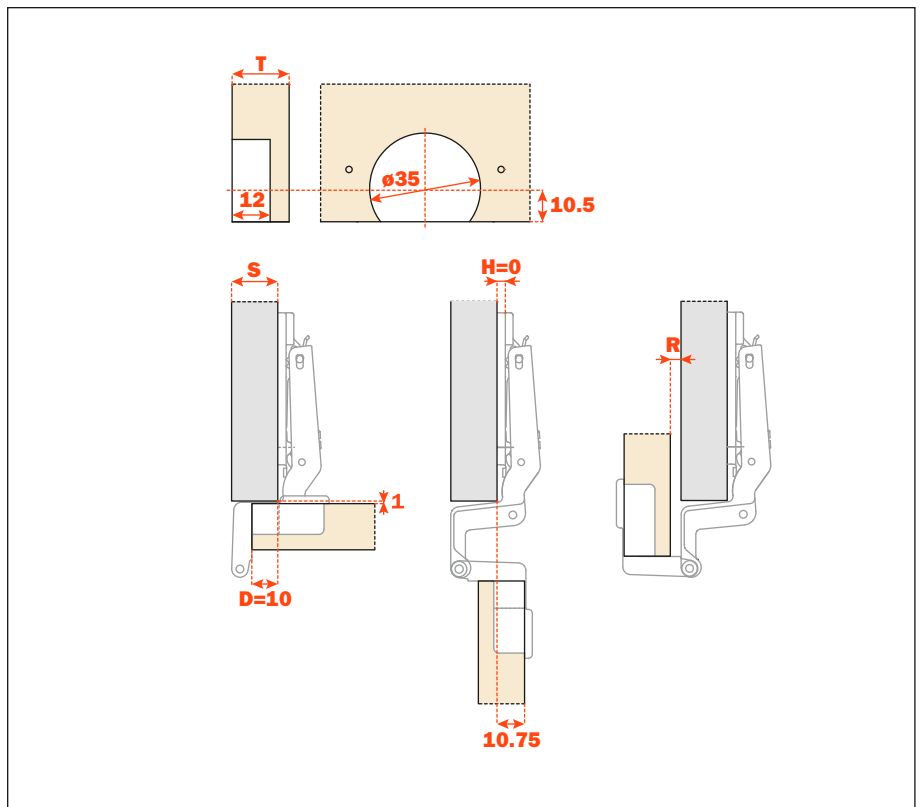

Application with inset door
Application avec porte rentrante

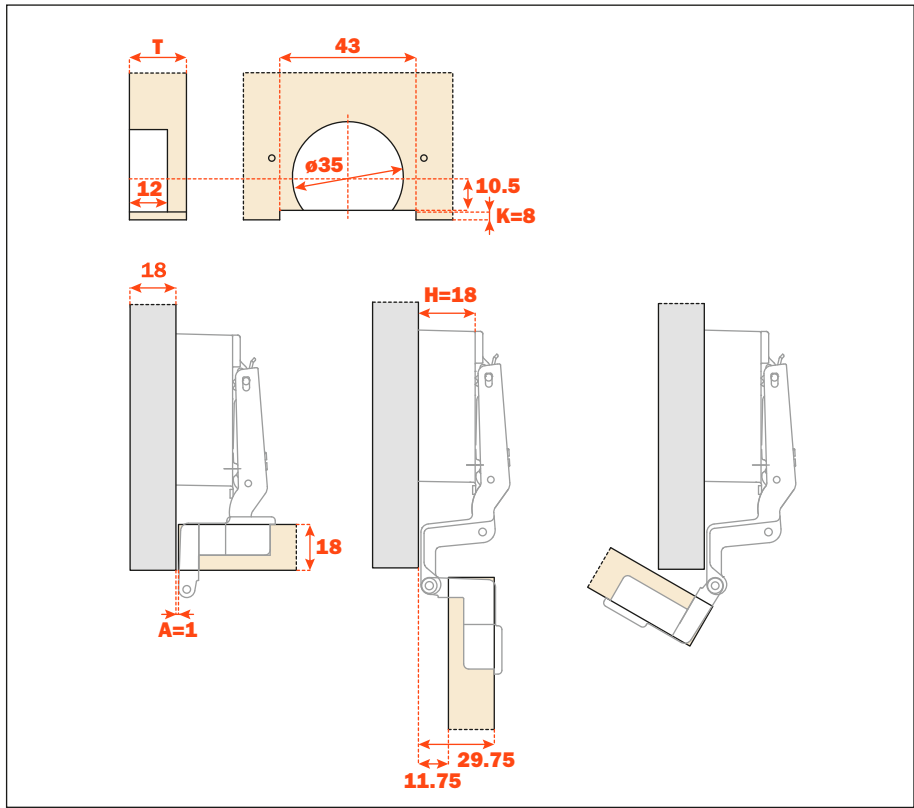

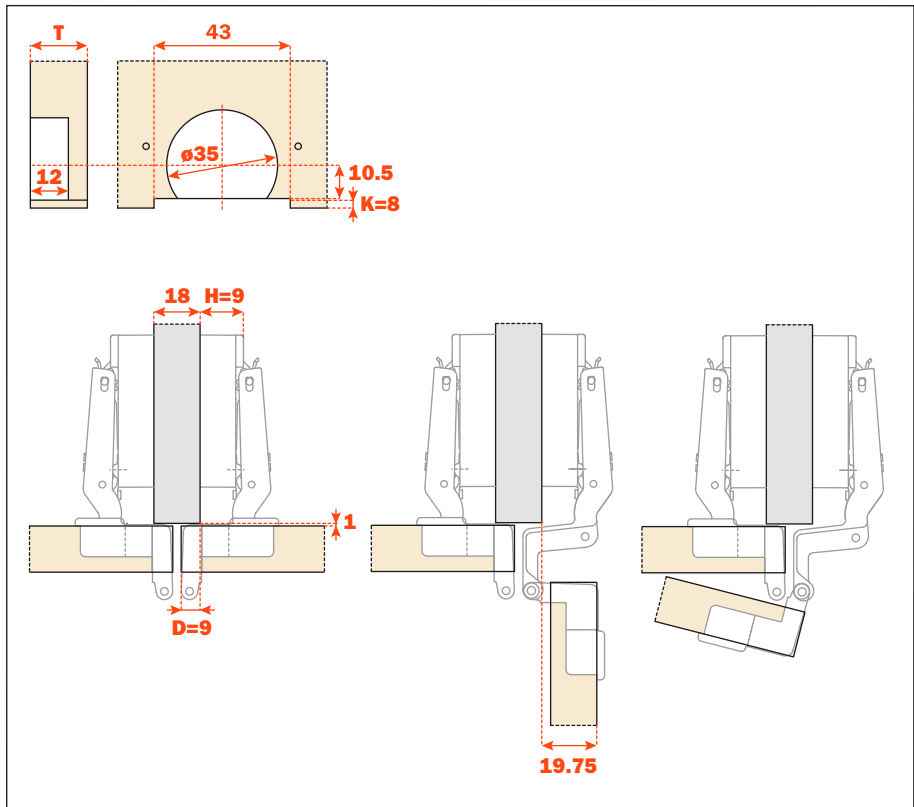

Application with half overlay door
Application pour porte jumelées

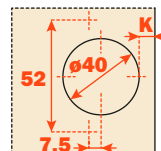

F series • For thick doors up to 1- 1/2" and other special applications
Série F • Pour portes épaisses jusqu' à 1 1/2" et d'autres applications spéciales

| | | |
|--|---|------------------------|
| | 94° ø40 | Packaging Emballage |
| |  | |





| | | | |
|------------|---|---------|-----|
| F/S |  | CFA5A99 | 300 |
| S/C |  | CFA7A99 | 300 |
| | | | |
| | | | |
| | | | |

This series has been designed to solve unusual application problems. For example, heavy thick doors (inset up to 40 mm) or overlays up to 34 mm. Also, the hinge of choice for pocket door applications.

Cup depth 13 mm, cup diameter 40 mm, opening 94 degrees, K = 3 to 15 mm.

Compensating side adjustment
-0.5 mm +5.5 mm.





| | | | |
|------------|---|---------|-----|
| F/S |  | CFA5G99 | 300 |
| S/C |  | CFA7G99 | 300 |
| | | | |
| | | | |
| | | | |

Cette série a été conçue pour résoudre des problèmes d'application peu courants. Exemple: portes lourdes et très épaisses (jusqu'à 40 mm) ou pour recouvrement jusqu'à 34 mm.

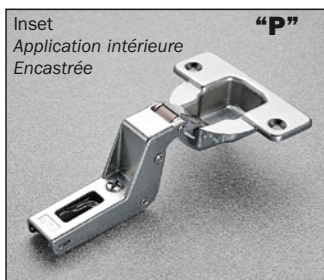
Aussi la charnière à choisir pour portes rétractables. Profondeur du boîtier 13 mm, diamètre du boîtier 40 mm, ouverture à 94°, K = de 3 à 15 mm.



| | | | |
|------------|---|---------|-----|
| F/S |  | CFA5P99 | 300 |
| S/C |  | CFA7P99 | 300 |
| | | | |
| | | | |
| | | | |

Réglage compensé de côté
-0.5 mm + 5.5 mm.

"C" value

With this formula you can obtain the max. thickness of the moulded door that can be opened without touching adjacent carcase sides, doors or walls, whilst bearing in mind the above L-K-T values.

L'encombrement

Par cette formule vous pouvez obtenir l'épaisseur maximum de la porte ouverte sans interférer avec côtés, portes ou parois adjacentes. Il faut aussi toujours tenir compte du tableau des valeurs L - K - T.

$$C=22.5 + K + A$$

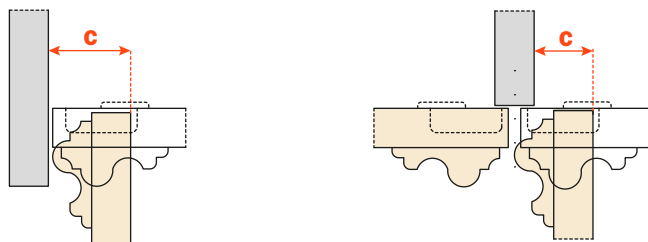

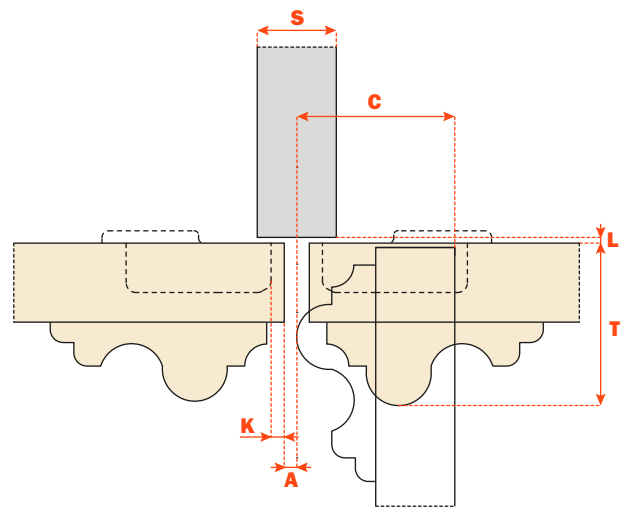
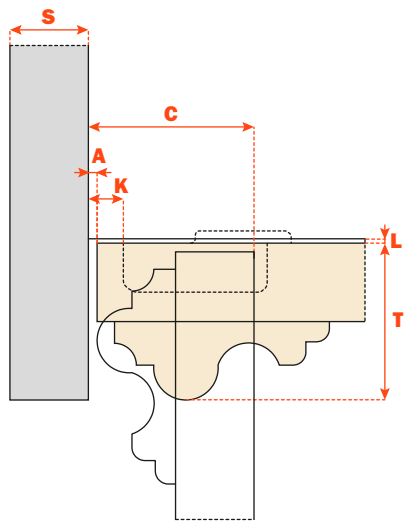

Overlay charts
Graphiques de recouvrement

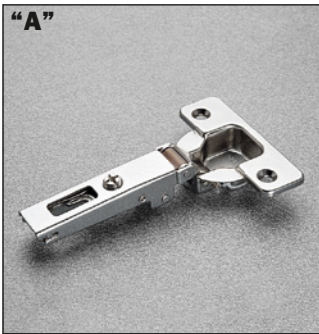

Full Overlay Hinge • Plein recouvrement Porte en applique

Hinge drilling pattern using "K" of 4 mm
Schéma de perçage avec "K" de 4 mm

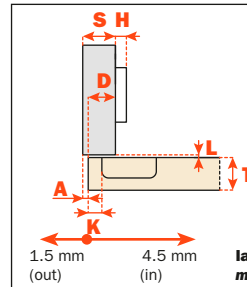
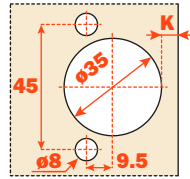

Full overlay constant = 15 mm
Porte en applique constante = 15 mm
 $D = (15 + K) - H$

lateral adjustment series
marge de réglage latéral

The OVERLAY values shown in the table below were calculated by using the following formula:

Required overlay (D) = (Hinge constant of 15 mm plus TAB value (K) minus the plate thickness (H).

Example: $D = (15 + K) - H$ or $19 \text{ mm} = (15 + 4) - 0$

Les valeurs RECOUVREMENT indiquées dans le tableau ci-dessous ont été calculées avec la formule suivante:

Recouvrement désiré (D) = (constante de la charnière de 15 mm plus la distance de perçage (K) moins l'épaisseur de l'embase (H).

Exemple : $D = (15 + K) - H$ ou $19 \text{ mm} = (15 + 4) - 0$

Salice's preferred TAB (K)
Distance de perçage (K) préférée de Salice

Applies only to 94° and 165° hinges
Uniquement pour charnières avec ouverture 94° et 165°

Applies only to 94° and 155° thick door hinges
Uniquement pour charnières avec ouverture 94° et 155° pour portes épaisses

| OVERLAY TABLE - TABLEAU RECOUVREMENT | | | Drilling Distance (TAB) - Distance de perçage (TAB) | | | | | | |
|--|-----------------------------|-------|---|----------|----------|----------|----------|----------|----------|
| | | | K = 3 mm | K = 4 mm | K = 5 mm | K = 6 mm | K = 7 mm | K = 8 mm | K = 9 mm |
| Plate thickness Epaisseur de l'embase | Euro Plates Embases Euro | 0 mm | 18 mm | 19 mm | 20 mm | 21 mm | 22 mm | 23 mm | 24 mm |
| | | 2 mm | 16 mm | 17 mm | 18 mm | 19 mm | 20 mm | 21 mm | 22 mm |
| | | 3 mm | 15 mm | 16 mm | 17 mm | 18 mm | 19 mm | 20 mm | 21 mm |
| | | 4 mm | 14 mm | 15 mm | 16 mm | 17 mm | 18 mm | 19 mm | 20 mm |
| | | 6 mm | 12 mm | 13 mm | 14 mm | 15 mm | 16 mm | 17 mm | 18 mm |
| | | 9 mm | 9 mm | 10 mm | 11 mm | 12 mm | 13 mm | 14 mm | 15 mm |
| | | 12 mm | 6 mm | 7 mm | 8 mm | 9 mm | 10 mm | 11 mm | 12 mm |
| | 18 mm | 0 mm | 1 mm | 2 mm | 3 mm | 4 mm | 5 mm | 6 mm | |
| | Face frame Face frame | 1 mm | 17 mm | 18 mm | 19 mm | 20 mm | 21 mm | 22 mm | 23 mm |
| | | 4 mm | 14 mm | 15 mm | 16 mm | 17 mm | 18 mm | 19 mm | 20 mm |
| 6 mm | | 12 mm | 13 mm | 14 mm | 15 mm | 16 mm | 17 mm | 18 mm | |



1/2" Overlay - Face frame • Recouvrement 1/2" - Face frame

Hinge drilling pattern using "K" of 4 mm
Schéma de perçage avec "K" de 4 mm

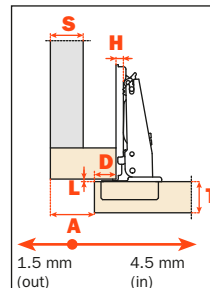
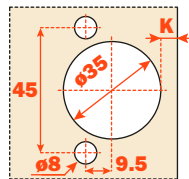

1/2" overlay hinge constant = 10 mm

Recouvrement 1/2" constante = 10 mm

$D = (10 + K) - H$

lateral adjustment series
marge de réglage latéral

The OVERLAY values found in the table below were calculated by using the following formula:

Required overlay (D) = (Hinge constant of 10 mm plus TAB value (K) minus the plate thickness (H).

Example: $D = (10 + K) - H$ or $13 \text{ mm} = (10 + 4) - 1$

NA = Not Applicable

Les valeurs RECOUVREMENT indiquées dans le tableau ci-dessous ont été calculées avec la formule suivante:

Recouvrement désiré (D) = (constante de la charnière de 10 mm plus la distance de perçage (K) moins l'épaisseur de l'embase (H).

Exemple: $D = (10 + K) - H$ ou $13 \text{ mm} = (10 + 4) - 1$

NA = n'est pas applicable

Salice's preferred TAB (K)
Distance de perçage (K) préférée de Salice

Applies only to 94° and 165° hinges
Uniquement pour charnières avec ouverture 94° et 165°

Applies only to 94° and 155° thick door hinges
Uniquement pour charnières avec ouverture 94° et 155° pour portes épaisses

| OVERLAY TABLE - TABLEAU RECOUVREMENT | | | Drilling Distance (TAB) - Distance de perçage (TAB) | | | | | | |
|--|-----------------------------|-------|---|----------|----------|----------|----------|----------|----------|
| | | | K = 3 mm | K = 4 mm | K = 5 mm | K = 6 mm | K = 7 mm | K = 8 mm | K = 9 mm |
| Plate thickness Epaisseur de l'embase | Euro Plates Embases Euro | 0 mm | 13 mm | 14 mm | 15 mm | 16 mm | 17 mm | 18 mm | 19 mm |
| | | 2 mm | 11 mm | 12 mm | 13 mm | 14 mm | 15 mm | 16 mm | 17 mm |
| | | 3 mm | 10 mm | 11 mm | 12 mm | 13 mm | 14 mm | 15 mm | 16 mm |
| | | 4 mm | 9 mm | 10 mm | 11 mm | 12 mm | 13 mm | 14 mm | 15 mm |
| | | 6 mm | 7 mm | 8 mm | 9 mm | 10 mm | 11 mm | 12 mm | 13 mm |
| | | 9 mm | 4 mm | 5 mm | 6 mm | 7 mm | 8 mm | 9 mm | 10 mm |
| | | 12 mm | 1 mm | 2 mm | 3 mm | 4 mm | 5 mm | 6 mm | 7 mm |
| | 18 mm | NA | NA | -3 mm | -2 mm | -1 mm | 0 mm | 1 mm | |
| | Face frame Face frame | 1 mm | 12 mm | 13 mm | 14 mm | 15 mm | 16 mm | 17 mm | 18 mm |
| | | 4 mm | 9 mm | 10 mm | 11 mm | 12 mm | 13 mm | 14 mm | 15 mm |
| 6 mm | | 7 mm | 8 mm | 9 mm | 10 mm | 11 mm | 12 mm | 13 mm | |



Half overlay • Demi recouvrement Portes jumelées

Hinge drilling pattern using "K" of 4 mm
Schéma de perçage avec "K" de 4 mm

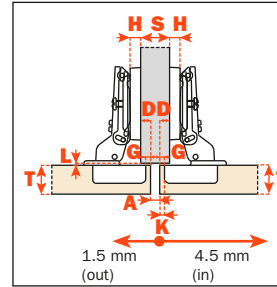
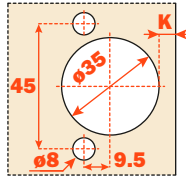

Half overlay hinge constant = 6 mm

Portes jumelées constante = 6 mm

$$D = (6 + K) - H$$

lateral adjustment series
marge de réglage latéral

The OVERLAY values found in the table below were calculated by using the following formula:

Required overlay (D) = (Hinge constant of 6 mm plus TAB value (K) minus the plate thickness (H).

Example: $D = (6 + K) - H$ or 10 mm = (6 + 4) - 0

NA = Not Applicable

Les valeurs RECOUVREMENT indiquées dans le tableau ci-dessous ont été calculées avec la formule suivante:

Recouvrement désiré (D) = (constante de la charnière de 6 mm plus la distance de perçage (K) moins l'épaisseur de l'embase (H).

Exemple: $D = (6 + K) - H$ ou 10 mm = (6 + 4) - 0

NA = n'est pas applicable

Salice's preferred TAB (K)
Distance de perçage (K) préférée de Salice

Applies only to 94° and 165° hinges
Uniquement pour charnières avec ouverture 94° et 165°

Applies only to 94° and 155° thick door hinges
Uniquement pour charnières avec ouverture 94° et 155° pour portes épaisses

| OVERLAY TABLE - TABLEAU RECOUVREMENT | | | Drilling Distance (TAB) - Distance de perçage (TAB) | | | | | | |
|--|-----------------------------|-------|---|----------|----------|----------|----------|----------|----------|
| | | | K = 3 mm | K = 4 mm | K = 5 mm | K = 6 mm | K = 7 mm | K = 8 mm | K = 9 mm |
| Plate thickness Epaisseur de l'embase | Euro Plates Embases Euro | 0 mm | 9 mm | 10 mm | 11 mm | 12 mm | 13 mm | 14 mm | 15 mm |
| | | 2 mm | 7 mm | 8 mm | 9 mm | 10 mm | 11 mm | 12 mm | 13 mm |
| | | 3 mm | 6 mm | 7 mm | 8 mm | 9 mm | 10 mm | 11 mm | 12 mm |
| | | 4 mm | 5 mm | 6 mm | 7 mm | 8 mm | 9 mm | 10 mm | 11 mm |
| | | 6 mm | 3 mm | 4 mm | 5 mm | 6 mm | 7 mm | 8 mm | 9 mm |
| | | 9 mm | 0 mm | 1 mm | 2 mm | 3 mm | 4 mm | 5 mm | 6 mm |
| | | 12 mm | -3 mm | -2 mm | -1 mm | 0 mm | 1 mm | 2 mm | 3 mm |
| | | 18 mm | NA | NA | NA | NA | NA | NA | -3 mm |
| | Face frame Face frame | 1 mm | 8 mm | 9 mm | 10 mm | 11 mm | 12 mm | 13 mm | 14 mm |
| | | 4 mm | 5 mm | 6 mm | 7 mm | 8 mm | 9 mm | 10 mm | 11 mm |
| 6 mm | | 3 mm | 4 mm | 5 mm | 6 mm | 7 mm | 8 mm | 9 mm | |



Inset • Application intérieure Encastrée

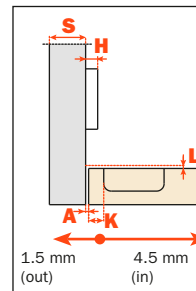
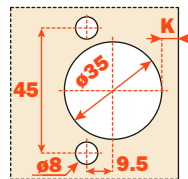

Inset hinge constant = -2 mm

Porte rentrante constante = -2 mm

$$H = (-2 + K) + A$$

lateral adjustment series
marge de réglage latéral

The OVERLAY values found in the table below were calculated by using the following formula:
Required plate height (H) = (Hinge constant of -2 mm plus TAB value (K) plus the "A" value (Gap).

Example: If a 1 mm gap is desired and drilling at 4 mm, use the formula $H = (-2 + K) + A$. $H = (-2 + 4) + 1$ or $H = 3$ mm.

NA = Not Applicable

Les valeurs RECOUVREMENT indiquées dans le tableau ci-dessous ont été calculées avec la formule suivante:
Hauteur de l'embase désirée (H) = (constante de la charnière de -2 mm plus la distance de perçage (K) plus la valeur "A" (jeu)
Exemple: si la valeur jeu "A" est 1 mm et le perçage est 4 mm, utiliser la formule : $H = (-2 + K) + A$. $H = (-2 + 4) + 1$ ou hauteur = 3 mm
NA = n'est pas applicable

Salice's preferred TAB (K)
Distance de perçage (K) préférée de Salice

Applies only to 94° and 165° hinges
Uniquement pour charnières avec ouverture 94° et 165°

Applies only to 94° and 155° thick door hinges
Uniquement pour charnières avec ouverture 94° et 165° pour portes épaisses

| OVERLAY TABLE - TABLEAU RECOUVREMENT | | | Drilling Distance (TAB) - Distance de perçage (TAB) | | | | | | | |
|--|-----------------------------|--------------------------|---|----------|----------|----------|----------|----------|----------|--|
| | | | K = 3 mm | K = 4 mm | K = 5 mm | K = 6 mm | K = 7 mm | K = 8 mm | K = 9 mm | |
| Plate thickness Epaisseur de l'embase | Euro Plates Embases Euro | 0 mm | +1 mm | NA | NA | NA | NA | NA | NA | |
| | | 2 mm | -1 mm | 0 mm | +1 mm | NA | NA | NA | NA | |
| | | 3 mm | -2 mm | -1 mm | 0 mm | +1 mm | NA | NA | NA | |
| | | 4 mm | -3 mm | -2 mm | -1 mm | 0 mm | NA | NA | NA | |
| | | 6 mm | NA | NA | -3 mm | -2 mm | -1 mm | 0 mm | +1 mm | |
| | | 9 mm | NA | NA | NA | NA | NA | -3 mm | -2 mm | |
| | | Face frame Face frame | NA | | | | | | | |



Mounting plates
Embases

Mounting plates - The Slide-on mounting plate system Embases à fixation ordinaire - A visser

The chart is based upon using a full overlay, "A" crank style, straight arm hinge with the combination of the baseplate thickness noted.
Les tableaux sont basés sur une application avec porte en applique, charnière bras « A », en combinaison avec l'épaisseur d'embase indiqué.

| Based on using full overlay hinges with a 15mm constant. Basé sur une application avec porte en applique avec constante 15 mm | Baseplate Thickness 0mm Side panel 19mm Full overlay | Baseplate Thickness 2mm Side panel 16 mm Full overlay | Baseplate Thickness 3mm Side panel 16 mm Full overlay | Baseplate Thickness 4mm Side panel 16 mm Full overlay | Baseplate Thickness 6mm 1/2" overlay Partial overlay | Baseplate Thickness 9mm Side panel 19 mm Half overlay | Baseplate Thickness 12mm Side panel 16 mm Half overlay | Baseplate Thickness 18mm Inset Epaisseur embase 18mm Porte rentrante | Packaging Emballage |
|--|---|--|---|--|---|---|--|--|------------------------|
| | Epaisseur embase 0mm Panneau latéral 19 mm Porte en applique | Epaisseur embase 2mm panneau latéral 16 mm Porte en applique plus jeu | Epaisseur embase 3mm panneau latéral 16 mm Porte en applique | Epaisseur embase 4mm panneau latéral 16 mm Porte en applique plus jeu | Epaisseur embase 6 mm 1/2" recouvrement Face frame à encadrement | Epaisseur embase 9mm panneau latéral 19 mm Porte jumelée | Epaisseur embase 12mm panneau latéral 16 mm Porte jumelée | | |
| | | | | | | | | | |

| 37x32 Screw-in 37x32 A visser | | | | | | | | | |
|--|------------|------------|------------|------------|------------|------------|-------------------------------|-------------------------------|-------------|
| Steel - Acier | | | | | | | | | |
| | B2V3H09/15 | B2V3H29/15 | B2V3H39/15 | B2V3H49/15 | B2V3H69/15 | B2V3H99/15 | B2V3BC9/15* Die-cast zamak | B2V3BV9/15* Die-cast zamak | 600 300* |

| 37x32 Screw-in Euro screw pre mounted 37x32 A visser vis euro | | | | | | | | | |
|--|------------|------------|------------|------------|------------|------------|-----------------------------|-------------------------------|-------------|
| Steel - Acier | | | | | | | | | |
| | B2VGH09/17 | B2VGH29/17 | B2VGH39/17 | B2VGH49/17 | B2VGH69/17 | B2VGH99/17 | B2VGC9/15 Die-cast Zamak | B2VGBV9/15* Die-cast Zamak | 600 300* |

| 37x32 Screw-in Height adjustment by cam 37x32 A visser - réglage vertical par vis excentrique | | | | | | | | | |
|--|------------|--|------------|--|-------------|-------------|--|--|-------------|
| Die-cast - Zamak | | | | | | | | | |
| | B2R3E09/15 | | B2R3E39/15 | | B2R3E69/15* | B2R3E99/15* | | | 600 300* |

| 37x32 Screw-in Euro screw pre mounted - Height adjustment by cam 37x32 A visser vis euro - Réglage vertical par vis excentrique | | | | | | | | | |
|--|------------|--|------------|--|-------------|-------------|--|--|-------------|
| Die-cast - Zamak | | | | | | | | | |
| | B2RGE09/17 | | B2RGE39/17 | | B2RGE69/17* | B2RGE99/17* | | | 600 300* |

| 37x32 Screw-in Ø5 Premounted ø5 mm expandable dowel 37x32 A visser Ø5 Goujons à expansion ø5 mm | | | | | | | | | |
|--|------------|------------|------------|------------|------------|--|--|--|-----|
| Steel - Acier | | | | | | | | | |
| | B2V4H09/17 | B2V4H29/17 | B2V4H39/17 | B2V4H49/17 | B2V4H69/17 | | | | 600 |

Mounting plates - The slide-on mounting plates system for special angle assembly - 3 way adjustment

Embases à fixation ordinaire - A visser - Pour des applications spéciales

An almost infinite variety of angled door applications is possible using variable-angle mounting plates in conjunction with one of Salice's range of angled-arm hinges.

En accouplant les embases Salice pou montage spéciaux avec les différents bras des charnières, il est possible d'obtenir d'innombrables solutions de montage d'angle des portes.

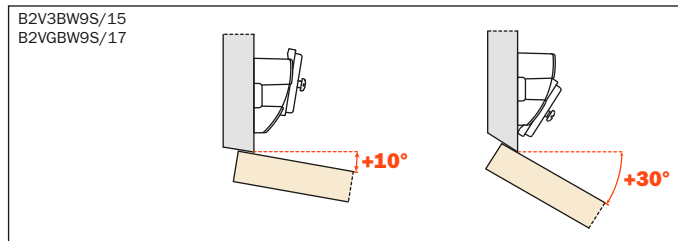
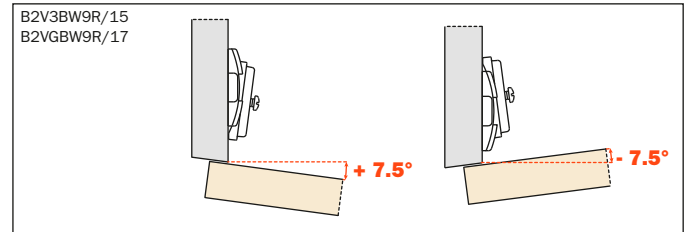
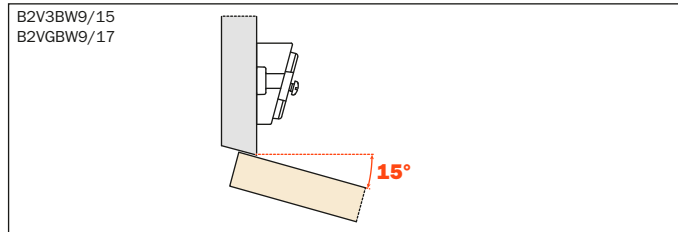

| | | Packaging Emballage | | | Packaging Emballage | | | Packaging Emballage2 |
|---|---|------------------------|---|--|------------------------|---|---|-------------------------|
|  | 37x32 Screw-in 37x32 A visser | |  | Euro screw pre-mounted. Vis Euro. | |  | Screw-in. A visser. | |
| Die-cast - Zamak | | | Die-cast - Zamak | | | Die-cast - Zamak | | |
|  | B2V3BW9/15 | 600 |  | B2VGBW9/17 | 600 |  | B2V3BW9R/15 | 600 |
|  | Screw-in. Euro screw pre-mounted. A visser vis Euro. | |  | Screw-in. A visser. | |  | Screw-in. Euro screw pre-mounted. A visser vis Euro. | |
| Die-cast - Zamak | | | Die-cast - Zamak | | | Die-cast - Zamak | | |
|  | B2VGBW9R/17 | 600 |  | B2V3BW9S/15 | 300 |  | B2VGBW9S/17 | 300 |



| | | | | |
|---|--------------------------------------|-----|--|--|
|  | Screw-in. A visser. | |  | |
| Die-cast - Zamak | | | | |
|  | BAR3RW9M | 150 | | |



Variable-angle adapters

Die-cast adapters for all mounting plates.

| | | |
|---|---|-----------|
|  | Die-cast adapter +5°. Fixing: wood screw $\varnothing 6 \times \frac{3}{4}$ " Adaptateur en zamak +5°. Fixation vis à bois. $\varnothing 6 \times \frac{3}{4}$ " | |
|  |  | SAV354X9R |

Adaptateurs inclinés

Adaptateurs en zamak pour toutes les embases.

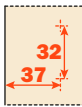
| | | |
|---|---|-----------|
|  | Die-cast adapter +10°. Fixing: wood screw $\varnothing 6 \times 1$ " Adaptateur en zamak +10°. Fixation vis à bois. $\varnothing 6 \times 1$ " | |
|  |  | SAV354X9S |

* Can be used with straight arm plates (BAP) or wing style plates (BAV, BAR)

** When stacked, use wood screw $\varnothing 6 \times 1 - \frac{1}{4}$ "











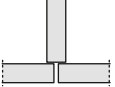
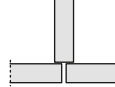





*** Stacking the adapters will allow the achievement of a 15° angle

* Peut être utilisé avec les embases longitudinales (BAP) ou cruciformes (BAV, BAR)

** Pour la fixation utiliser une vis à bois $\varnothing 6 \times 1 - \frac{1}{4}$ "

*** En fixant les adaptateurs, on obtient un angle de 15°

Mounting plates • snap on - 2-way adjustment - 1 cam
Embases • à fixation rapide - 2 réglages - 1 vis excentrique

| | | | | | | |
|---|---|---|---|---|--|-----|
| <p>Based on using full overlay hinges</p> <p><i>Utilisation avec plein recouvrement, porte en applique</i></p> | <p>9 mm Side panel 19 mm Half overlay</p> <p><i>Côté 19 mm Demi recouvrement</i></p>  | <p>12 mm Side panel 16 mm Half overlay</p> <p><i>Côté 16 mm Demi recouvrement</i></p>  | <p>18 mm Inset</p> <p><i>Application intérieure</i></p>  | | Packaging Emballage | |
|  | <p>37x32 Screw-in 37x32 A visser</p> | | | | | |
| Die-cast - Zamak  | Die cast Zamak BAV3E99F | Die cast Zamak BAV3EC9F | Die cast Zamak BAV3EV9F | | 300 | |
|  | <p>37x32 Screw-in. Euro screw pre-mounted. 37x32 A visser. Eurovis pré-monté.</p> | | | | | |
| Die-cast - Zamak  | Die cast Zamak BAVGE99F/16 | Die cast Zamak BAVGEC9F/16 | Die cast Zamak BAVGEV9F/16 | | 300 | |
| <p>New steel mounting plates</p> <p><i>Nouvelles embases en acier</i></p> | <p>0 mm Side panel 19 mm Full overlay</p> <p><i>Côté 19 mm Plein recouvrement</i></p>  | <p>2 mm Side panel 16 mm Full overlay</p> <p><i>Côté 16 mm Plein recouvrement</i></p>  | <p>3 mm Side panel 16 mm Full overlay</p> <p><i>Côté 16 mm Plein recouvrement</i></p>  | <p>4 mm Side panel 16 mm Full overlay</p> <p><i>Côté 16 mm Plein recouvrement</i></p>  | <p>6 mm $\frac{1}{2}$" overlay Partial overlay</p> <p><i>Recouvrement $\frac{1}{2}$" Recouvrement partiel</i></p>  | |
|  | <p>37x32 Screw-in 37x32 A visser</p> | | | | | |
| Steel - Acier  | BAV3M09F | BAV3M29F | BAV3M39F | BAV3M49F | BAV3M69F | 300 |
|  | <p>37x32 Screw-in. Euro screw pre-mounted. 37x32 A visser. Eurovis pré-monté.</p> | | | | | |
| Steel - Acier  | BAVGM09F/16 | BAVGM29F/16 | BAVGM39F/16 | BAVGM49F/16 | BAVGM69F/16 | 300 |
|  | <p>37x32 Screw-in. Expansion dowels ø 5 mm 37x32 A visser. Tourillons à expansion ø 5 mm.</p> | | | | | |
| Steel - Acier  | BAV4M09F/16 | BAV4M29F/16 | BAV4M39F/16 | BAV4M49F/16 | | 300 |

Snap on - 2-way adjustment - 2 cams
A fixation rapide - 2 réglages - 2 vis excentriques









The Domi automatic mounting plate system - 2-way adjustment
Domi plate with AAR feature.

The **Salice Domi** mounting plate has a unique **Automatic Adjustment Response** feature: a slight turn of the depth adjustment cam or vertical adjustment cam quickly positions the hinge - eliminating the need for manual positioning by loosening screws.

Embases Domi à fixation rapide - 2 réglages

Embase Domi avec fonction RRA.

L'Embase Domi de Salice a une fonction unique de **Réponse de Régulation Automatique**: une rotation rapide de la vis excentrique pour le réglage frontal ou vertical, positionne automatiquement la charnière - éliminant ainsi le besoin de positionnement manuel.

| | | | | | |
|---|---|---|--|---|--------------------------------|
| <p>Based on using full overlay hinges.</p> <p>Utilisation avec plein recouvrement, porte en applique.</p> | <p>0 mm Side panel 19 mm Full overlay</p> <p>Côté 19 mm Plein recouvrement</p>  | <p>3 mm Side panel 16 mm Full overlay</p> <p>Côté 16 mm Plein recouvrement</p>  | <p>4mm Side panel 16 mm Full overlay</p> <p>Panneau latéral 16 mm Porte en applique plus jeu</p>  | <p>6 mm $\frac{1}{2}$" overlay Partial overlay</p> <p>Recouvrement $\frac{1}{2}$" Recouvrement partiel</p>  | <p>Packaging Emballage</p> |
|  | <p>37x32 #7 x 5/8" wood screw. 37x32 vis à bois #7 x 5/8".</p> | | | | |
| <p>Die-cast - Zamak</p>  | <p>BAR3L09F</p> | <p>BAR3L39F</p> | <p>BAR3L49F</p> | <p>BAR3L69F</p> | <p>300</p> |
|  | <p>37x32 Screw-in. Euro-screw pre-mounted. 37x32 A visser. Eurovis prémonté.</p> | | | | |
| <p>Die-cast - Zamak</p>  | <p>BARGL09F/16</p> | <p>BARGL39F/16</p> | <p>BARGL49F/16</p> | <p>BARGL69F/16</p> | <p>300</p> |

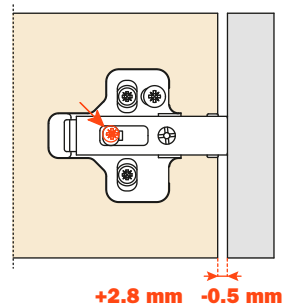
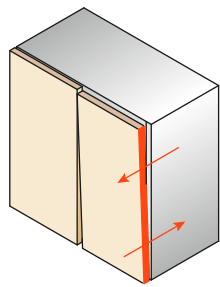
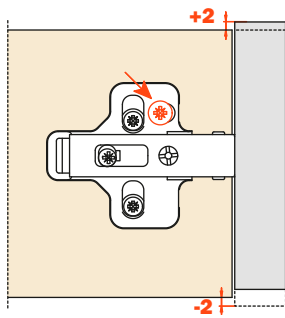
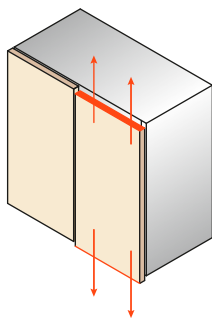

Height adjustment by cam
Réglage vertical par vis excentrique

+2 mm
-2 mm

Depth adjustment by cam
Réglage frontal par vis excentrique

+2.8 mm
-0.5 mm

Mounting plates • snap on - 2-way adjustment - 2 cams

Embases • à fixation rapide - 2 réglages - 2 vis excentriques

The Domi automatic mounting plate system - 2-way adjustment

Dom plate with AAR feature.

The **Salice Domi** mounting plate has a unique **Automatic Adjustment Response** feature: a slight turn of the depth adjustment cam or vertical adjustment cam quickly positions the hinge - eliminating the need for manual positioning by loosening screws.

Embases Domi à fixation rapide - 2 réglages

Embase Domi avec fonction RRA.

L'Embase **Domi** de **Salice** a une fonction unique de **Réponse de Régulation Automatique**: une rotation rapide de la vis excentrique pour le réglage frontal ou vertical, positionne automatiquement la charnière - éliminant ainsi le besoin de positionnement manuel

| Based on using full overlay hinges. Utilisation avec plein recouvrement, porte en applique. | 0 mm Side panel 19 mm Full overlay Côté 19 mm Plein recouvrement | 2 mm Side panel 16 mm Full overlay Côté 16 mm Recouvrement | 3 mm Side panel 16 mm Full overlay Côté 16 mm Plein recouvrement | 4 mm Side panel 16 mm Full overlay Côté 16 mm Plein recouvrement | 6 mm 1/2" overlay Partial overlay Recouvrement 1/2" Recouvrement partiel | 9 mm Side panel 19 mm Half overlay Côté 19 mm Demi recouvrement | 12 mm Side panel 16 mm Half overlay Côté 16 mm Demi recouvrement | Packaging Emballage |
|--|---|---|---|---|--|--|---|------------------------|
| | | | | | | | | |

| 21+32 Screw-in 21+32 A visser | | | | | | | | |
|--|---------|---------|---------|---------|---------|---------|---------|-----|
| Die-cast - Zamak | BAP3R09 | BAP3R29 | BAP3R39 | BAP3R49 | BAP3R69 | BAP3R99 | BAP3RC9 | 300 |

| 21+32 Screw-in. Euro-screw pre-mounted. 21+32 A visser. Eurovis pré-monté. | | | | | | | | |
|---|------------|------------|------------|------------|------------|--|--|-----|
| Die-cast - Zamak | BAPGR09/16 | BAPGR29/16 | BAPGR39/16 | BAPGR49/16 | BAPGR69/16 | | | 300 |

| 21+32 Knock-in. Dowels ø 10 mm. 21+32 Tourillons à pression ø 10 mm. | | | | | | | | |
|---|---------|---------|---------|---------|---------|--|--|-----|
| Die-cast - Zamak | BAP7R09 | BAP7R29 | BAP7R39 | BAP7R49 | BAP7R69 | | | 300 |

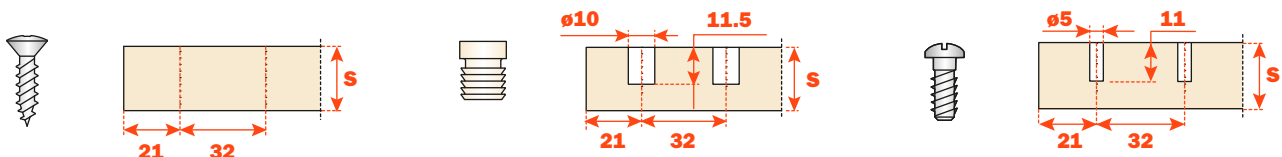

Snap on - 2-way adjustment - 2 cams

A fixation rapide - 2 réglages - 2 vis excentriques

The Domi automatic mounting plate system - 2-way adjustment • Domi plate with AAR feature.



The **Salice Domi** mounting plate has a unique **A**utomatic **A**djustment **R**esponse feature: a slight turn of the depth adjustment cam or vertical adjustment cam quickly positions the hinge - eliminating the need for manual positioning by loosening screws.



Embases Domi à fixation rapide - 2 réglages



Embase Domi avec fonction RRA.



L'Embase Domi de Salice a une fonction unique de **R**éponse de **R**égulation **A**utomatique: une rotation rapide de la vis excentrique pour le réglage frontal ou vertical, positionne automatiquement la charnière - éliminant ainsi le besoin de positionnement manuel.

| | | | | | | | | | |
|--|---|---|---|---|--|---|--|---|------------------------|
| Based on using full overlay hinges. Utilisation avec plein recouvrement, porte en applique. | 0 mm Side panel 19 mm Full overlay | 2 mm Side panel 16 mm Full overlay | 3 mm Side panel 16 mm Full overlay | 4 mm Side panel 16 mm Full overlay | 6 mm $\frac{1}{2}$ " overlay Partial overlay Recouvrement $\frac{1}{2}$ " Recouvrement partiel | 9 mm Side panel 19 mm Half overlay | 12 mm Side panel 16 mm Half overlay | 18 mm Inset Application intérieure | Packaging Emballage |
| | Côté 19 mm Plein recouvrement | Côté 16 mm Recouvrement | Côté 16 mm Plein recouvrement | Côté 16 mm Plein recouvrement | | Côté 19 mm Demi recouvrement | Côté 16 mm Demi recouvrement | | |

| | | | | | | | | | |
|---|--|---------|---------|---------|---------|---------|---------|---------|-----|
|  | 37x32 Screw-in 3rd screw fixing option 37x32 A visser. Possibilité de fixation par 3^{ème} vis | | | | | | | | |
| Die-cast - Zamak  | BAR3R09 | BAR3R29 | BAR3R39 | BAR3R49 | BAR3R69 | BAR3R99 | BAR3RC9 | BAR3RV9 | 300 |

| | | | | | | | | | |
|---|--|------------|------------|------------|------------|------------|-----------|------------|-----|
|  | 37x32 Screw-in. Euro-screw pre-mounted. 3rd screw fixing option 37x32 A visser. Eurovis pré-monté. Possibilité de fixation par 3^{ème} vis | | | | | | | | |
| Die-cast - Zamak  | BARGR09/16 | BARGR29/16 | BARGR39/16 | BARGR49/16 | BARGR69/16 | BARGR99/16 | BARGRC/16 | BARGRV9/16 | 300 |

| | | | | | | | | | |
|---|--|------------|------------|------------|------------|------------|--|--|-----|
|  | Short euro screw plates for twin application Eurovis courte pour application jumelées | | | | | | | | |
|  | BARGR09/20 | BARGR29/20 | BARGR39/20 | BARGR49/20 | BARGR69/20 | BARGR99/20 | | | 300 |

| | | | | | | | | | |
|---|---|------------|------------|------------|------------|--|--|--|-----|
|  | 37x32 Expansion Dowels ø5 mm. 3rd screw fixing option 37x32 Tourillons à expansion ø5 mm. Possibilité de fixation par 3^{ème} vis | | | | | | | | |
| Die-cast - Zamak  | BAR4R09/16 | BAR4R29/16 | BAR4R39/16 | BAR4R49/16 | BAR4R69/16 | | | | 300 |

Mounting plates • snap on - 2-way adjustment - 2 cams









Embases • à fixation rapide - 2 réglages - 2 vis excentriques

The Domi automatic mounting plate system - 2-way adjustment • Domi plate with AAR feature.

The **Salice Domi** mounting plate has a unique **Automatic Adjustment Response** feature: a slight turn of the depth adjustment cam or vertical adjustment cam quickly positions the hinge - eliminating the need for manual positioning by loosening screws.

Embases Domi à fixation rapide - 2 réglages Embase Domi avec fonction RRA.

L'Embase Domi de Salice a une fonction unique de **Réponse de Régulation Automatique**: une rotation rapide de la vis excentrique pour le réglage frontal ou vertical, positionne automatiquement la charnière - éliminant ainsi le besoin de positionnement manuel.

| | | | | | |
|---|---|---|--|---|--------------------------------|
| <p>Based on using full overlay hinges.</p> <p><i>Utilisation avec plein recouvrement, porte en applique.</i></p> | <p>21 mm Inset face frame application</p> <p>Application intérieure face frame</p>  | <p>24 mm Inset face frame application</p> <p>Application intérieure face frame</p>  | <p>27 mm Inset face frame application</p> <p>Application intérieure face frame</p>  | <p>30 mm Inset face frame application</p> <p>Application intérieure face frame</p>  | <p>Packaging Emballage</p> |
|  | <p>37x32 Screw-in 3rd screw fixing option • Additional plate heights 37x32 A visser. Possibilité de fixation par 3^{ème} vis • Hauteurs supplémentaires des embases</p> | | | | |
| <p>Die-cast - Zamak</p>  | <p>BAR3RZ9</p> | <p>BAR3RY9</p> | <p>BAR3RU9</p> | <p>BAR3RM9</p> | <p>150</p> |
|  | <p>37x32 Screw-in. Euro-screw pre-mounted. 3rd screw fixing option • Additional plate heights 37x32 A visser. Eurovis prémonté. Possibilité de fixation par 3^{ème} vis • Hauteurs supplémentaires des embases</p> | | | | |
| <p>Die-cast - Zamak</p>  | <p>BARGRZ9/16</p> | <p>BARGRY9/16</p> | <p>BARGRU9/16</p> | <p>BARGRM9/16</p> | <p>150</p> |

Snap on - 2-way adjustment - 1 cam and 2 cams
A fixation rapide - 2 réglages - 1 vis excentrique et 2 vis excentriques

| | | | | | |
|--|--|--|--|--|------------------------|
| Face frame application. Based on using full overlay hinges. Application face frame. Utilisation avec plein recouvrement, porte en applique. | 1 mm 3/4" overlay Recouvrement 3/4" | 4 mm 1/2" overlay Recouvrement 1/2" | | | Packaging Emballage |
| | | | | | |

| | | | | | |
|--|---------|---------|--|--|-----|
| 10x48 Screw-in. 10x48 A visser. | | | | | |
| Steel - Acier | BAU3L19 | BAU3L49 | | | 300 |

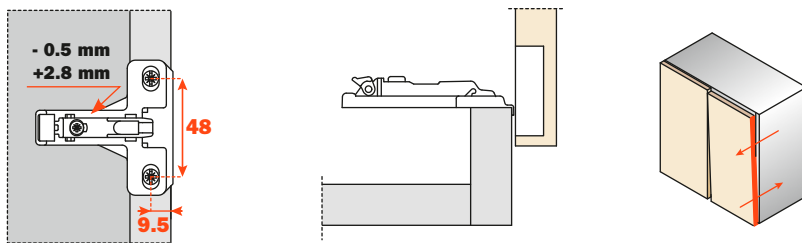

| | | | | | |
|--|--|--|--|--|--|
| | | 1 mm 3/4" overlay Recouvrement 3/4" | 4 mm 1/2" overlay Recouvrement 1/2" | 6 mm 1/2" overlay Recouvrement 1/2" | |
| | | | | | |

| | | | | | |
|--|----------|-----------|-----------|-----------|-----|
| 10x48 Screw-in. 3rd screw fixing option. 10x48 A visser. Possibilité de fixation par 3ème vis. | | | | | |
| Die-cast - Zamak | 9.5 | BAU3R19 | BAU3R49 | BAU3R69 | 300 |
| | 12.5 | BAU3R19XR | BAU3R49XR | BAU3R69XR | 300 |

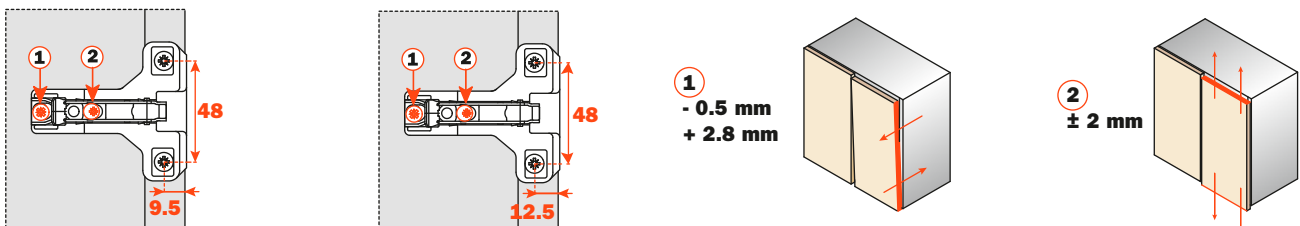

Mounting plates • 2-way adjustment - 2 cams

Embases • 2 réglages - 2 vis excentriques

Double cam - Inset face-frame applications • Vis excentrique double - Application intérieure face frame



Die-cast
Zamak

| | | |
|---|---------|------------------------|
| 7x32 Screw-in 7x32 A visser | | Packaging Emballage |
|  | BAL3R59 | 300 |

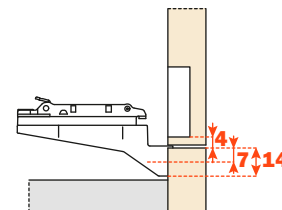
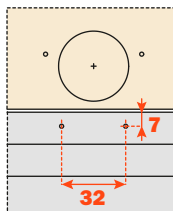

To be used with:

- 1) Half overlay hinges ("G" crank)
 - 2) 1/2" overlay hinges ("D" crank) + adjustment.
- Fix with #6 x 5/8" truss head recommended.

A utiliser avec:

- 1 - Demi recouvrement/Portes jumelées (bras "G")
 - 2 - Face frame à encadrement (bras "D") + réglage
- Nous recommandons la fixation avec vis à tête de ferme #6 x 5/8"

Double cam - Rear flange face-frame applications • Vis excentrique double - Pour les applications face frame à l'intérieur du cadre



Die-cast
Zamak

| | | |
|---|---------|------------------------|
| 10x45 Screw-in 10x45 A visser | | Packaging Emballage |
|  | BA03R59 | 150 |

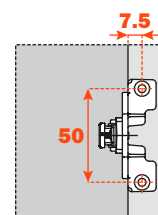
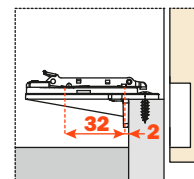
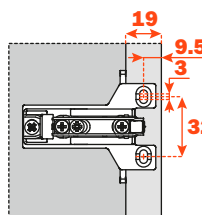

Overlay calculation:

Overlay = constant + Drilling distance - 5 mm

This wrap-around mounting plate allows attaching to both the edge of the frame as well as attaching to the back of the frame.

It is ideal for many specialized applications that include cabinet refacing when an up-to-6mm veneer is added to the face of the frame.

In this application, this plate design allows the fixing screws to remain in the center of the solid wood frame thus avoiding the joint between the frame and the surfacing material. Some manufacturers do not use solid wood framing material but other materials such as plywood or MDF. Since these materials do not provide suitable screw holding power on the edge of the material, this plate can be secured both to the back surface of the frame and the edge. This results in an acceptable, secure attachment.

Calculer le recouvrement :

Recouvrement = constante + distance de perçage - 5 mm

Cette embase enveloppante permet de la fixer aussi bien sur le bord du cadre qu'à l'arrière du cadre. Elle est idéal pour de nombreuses applications spécialisées y compris les revêtements du meuble lorsqu'un placage de jusqu'à 6 mm est ajouté à la face du cadre. Dans cette application, cette conception d'embase permet aux vis de fixation de s'enfoncer au centre du cadre en bois massif, évitant ainsi le joint entre le cadre et le matériau de recouvrement. Certains fabricants n'utilisent pas de matériaux en bois massif, mais d'autres matériaux tels que le contreplaqué ou le MDF. Étant donné que ces matériaux n'offrent pas une force de maintien de vis adéquate au bord du matériau, cette embase peut être fixée à la fois à la surface arrière du cadre et au bord. Il en résulte une fixation acceptable et sûre.

Double cam - Large overlay face-frame applications • Vis excentrique double - Pour les applications face frame à l'intérieur du cadre



Die-cast
Zamak

| | | |
|---|---------|------------------------|
| 10x45 Screw-in 10x45 A visser | | Packaging Emballage |
|  | BAM3R09 | 300 |

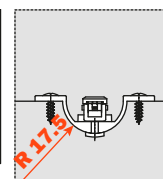
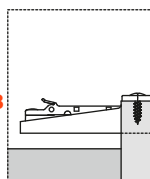
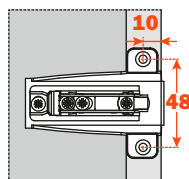

Overlay calculation:

Overlay = constant + Drilling distance + 11 mm

Calculer le recouvrement :

Recouvrement = constante + distance de perçage + 11 mm

| Hinge Charnière | Overlay Recouvrement | Drilling distance (K) Distance de perçage (K) |
|--|---|---|
| Full Overlay ("A" crank) • 110° - 120° opening Plein recouvrement (bras "A") • ouverture 110° - 120° | 1 - 1/4" overlay recouvrement 1 - 1/4" | K = 6 mm |
| Full Overlay ("A" crank) • 94° - 165° opening Plein recouvrement (bras "A") • ouverture 94° - 165° | 1 - 3/8" overlay recouvrement 1 - 3/8" | K = 8 mm + 1 mm of adjustment K = 8 mm + réglage de 1 mm |
| Full Overlay ("A" crank) • 165° + reduction clip • S2AF37X3 = 125° opening Plein recouvrement (bras "A") • 165° + arrêt S2AF37X3 = ouverture 125° | 1 - 1/2" overlay recouvrement 1 - 1/2" | K = 12 mm |
| Full Overlay ("A" crank) • 165° + reduction clip • S2AF37X3 = 125° opening Plein recouvrement (bras "A") • 165° + arrêt S2AF37X3 = ouverture 125° | 1 - 9/16" overlay recouvrement 1 - 9/16" | K = 14 mm |

Snap on - 2-way adjustment - 2 cams
A fixation rapide - 2 réglages - 2 vis excentriques

Hinge and mounting plate selection guide for Face Frame Inset doors.
Charnières et embases pour les applications face frame à l'intérieur du cadre

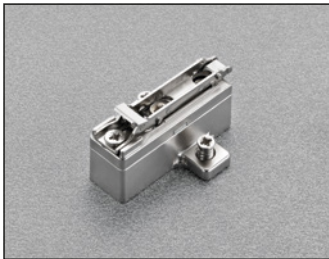

BAR_ mounting plate

BAR_ Embase

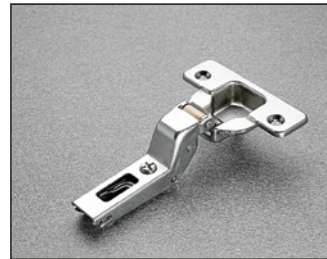

P_ crank inset hinge

P_ bras de la charnière pour application intérieure

Face frame cabinets

The **BAR** thick mounting plate system has been developed to offer the appropriate mounting plate thickness for inset doors with face frame cabinets. This eliminates the need to “build up” to match the face frame interspace (**IS**) dimension.

Muebles face frame

Le système des embases épaisses **BAR** a été développé pour offrir l'épaisseur approprié de l'embase pour les portes encastrées avec des meubles face frame. Cela élimine le besoin de “augmenter” pour niveler la dimension correspondant à la distance (**IS**) entre le côté et le bord du cadre.

Mounting plate part number

Référence de l'embase

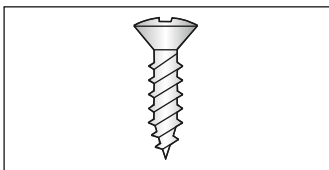

- H = 6 mm** - BAR3R69
- H = 9 mm** - BAR3R99
- H = 12 mm** - BAR3RC9
- H = 18 mm** - BAR3RV9
- H = 21 mm** - BAR3RZ9
- H = 24 mm** - BAR3RY9
- H = 27 mm** - BAR3RU9
- H = 30 mm** - BAR3RM9

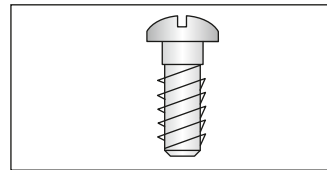

- H = 6 mm** - BARGR69/16
- H = 9 mm** - BARGR99/16
- H = 12 mm** - BARGRC9/16
- H = 18 mm** - BARGRV9/16
- H = 21 mm** - BARGRZ9/16
- H = 24 mm** - BARGRY9/16
- H = 27 mm** - BARGRU9/16
- H = 30 mm** - BARGRM9/16

3rd fixing screw hole from 0 mm to 12 mm.
 No 3rd fixing screw hole from 18 mm to 30 mm.

18 mm - 30 mm plates have larger screw holes requiring larger screws such as #7 X 5/8" wood screws.

3ème trou de vis de fixation de 0 mm à 12 mm.
 Pas de 3ème trou de vis de fixation de 18 mm à 30 mm.

Les embases de 18 mm à 30 mm ont des trous de vis plus grands nécessitant des vis plus grandes telles que des vis à bois #7 X 5/8".

3rd fixing screw hole from 0 mm to 12 mm.
 No 3rd fixing screw hole from 18 mm to 30 mm.

3ème trou de vis de fixation de 0 mm à 12 mm.
 Pas de 3ème trou de vis de fixation de 18 mm à 30 mm.

Drawings of Face Frame Inset applications
Dessins des applications intérieures face frame

Select an inset style (P crank) hinge and the matching mounting plate thickness for your cabinet design.
 Sélectionner une charnière bras P (application intérieure/encastree) et l'épaisseur de l'embase correspondant pour la conception de votre meuble.

| | |
|-------------------------|--------------------------|
| IS = Flush | IS = Aligné |
| P = Inset hinge | P = Encastrée |
| H = 3 mm plate | H = Embase 3 mm |
| K = 4 mm | K = 4 mm |
| A = 2.5 mm | A = 2.5 mm |
| Adjust = +1.5 mm | Réglage = +1.5 mm |

| | |
|------------------------|------------------------|
| IS = 1/16" | IS = 1/16" |
| P = Inset hinge | P = Encastrée |
| H = 6 mm plate | H = Embase 6 mm |
| K = 4 mm | K = 4 mm |
| A = 2.5 mm | A = 2.5 mm |
| Adjust = 0 mm | Réglage = 0 mm |

| | |
|-------------------------|--------------------------|
| IS = 1/8" | IS = 1/8" |
| P = Inset hinge | P = Encastrée |
| H = 6 mm plate | H = Embase 6 mm |
| K = 4 mm | K = 4 mm |
| A = 2.5 mm | A = 2.5 mm |
| Adjust = +1.5 mm | Réglage = +1.5 mm |

| | |
|-------------------------|--------------------------|
| IS = 1/4" | IS = 1/4" |
| P = Inset hinge | P = Encastrée |
| H = 9 mm plate | H = Embase 9 mm |
| K = 4 mm | K = 4 mm |
| A = 2.5 mm | A = 2.5 mm |
| Adjust = +1.5 mm | Réglage = +1.5 mm |

| | |
|------------------------|-------------------------|
| IS = 3/8" | IS = 3/8" |
| P = Inset hinge | P = Encastrée |
| H = 12 mm plate | H = Embase 12 mm |
| K = 4 mm | K = 4 mm |
| A = 2.5 mm | A = 2.5 mm |
| Adjust = +2 mm | Réglage = +2 mm |

| | |
|-------------------------|--------------------------|
| IS = 1/2" | IS = 1/2" |
| P = Inset hinge | P = Encastrée |
| H = 18 mm plate | H = Embase 18 mm |
| K = 4 mm | K = 4 mm |
| A = 2.5 mm | A = 2.5 mm |
| Adjust = -0.5 mm | Réglage = -0.5 mm |

Legend

IS = recess (from side to frame edge)
B = mounting plate
H = mounting plate thickness
K = edge bore distance
A = gap
P = crank inset hinge

Abréviations

IS = distance entre le côté et le bord du cadre
B = embase
H = épaisseur de l'embase
K = distance de perçage du bord extérieur
A = jeu
P = bras de la charnière pour application intérieure

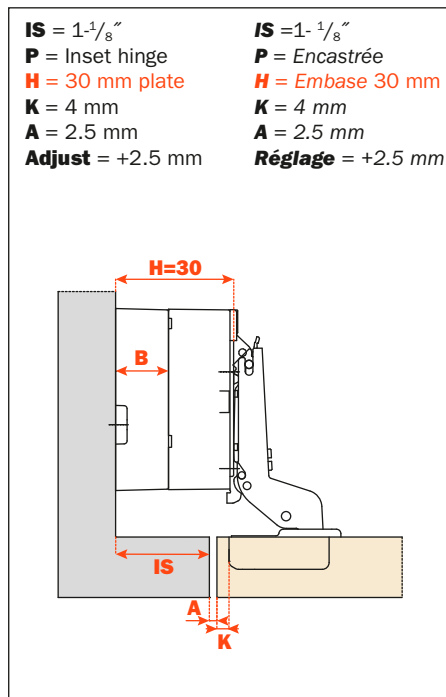
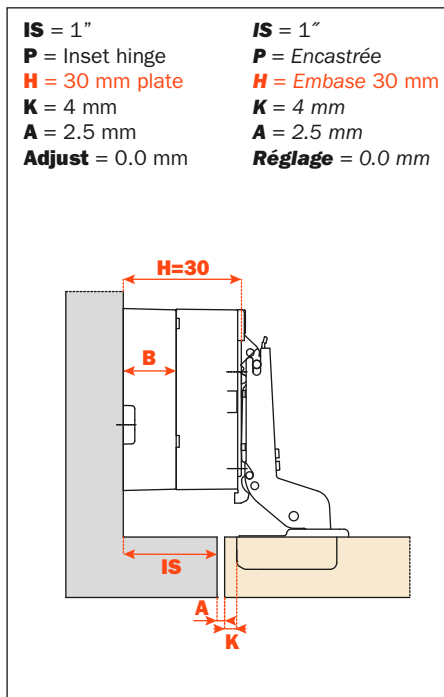
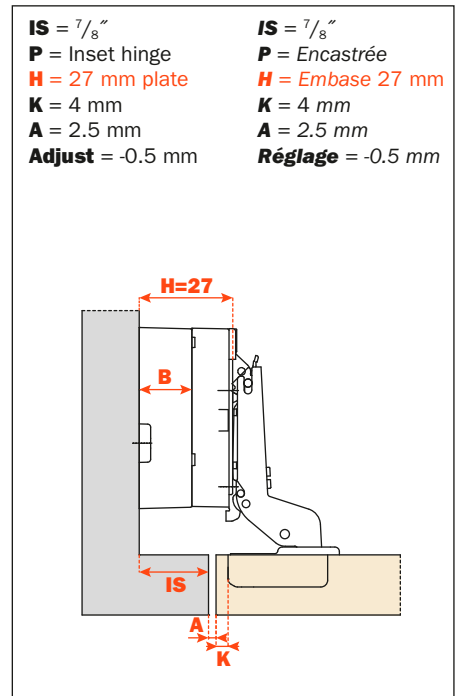
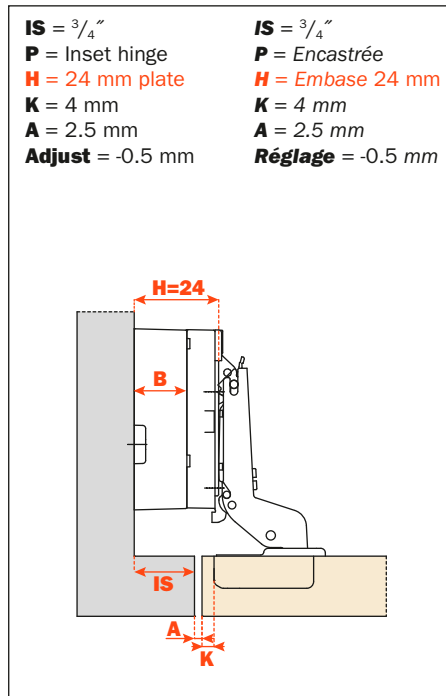
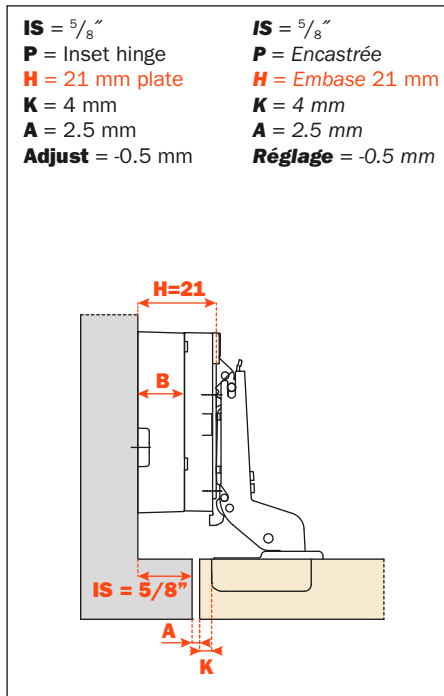

eocentra

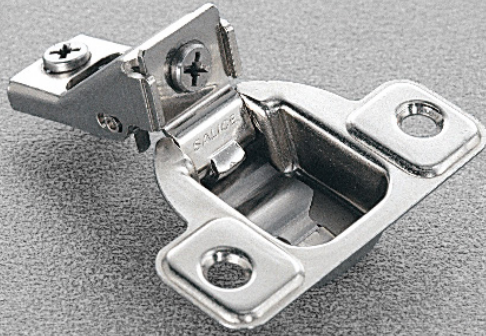

eocen *three*

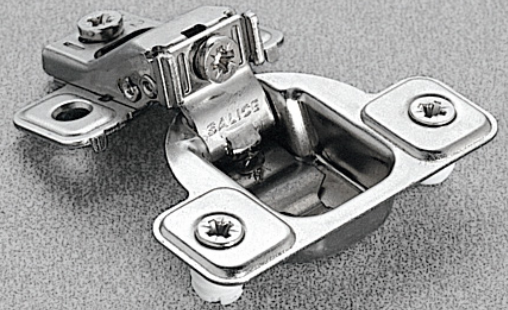

S series • Série S

S series Série S



"Face-Frame" • 2 cam adjustable "Face-Frame" • 2 vis excentriques réglables

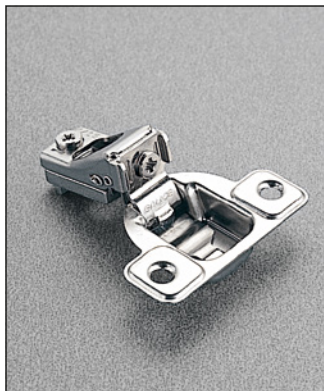

| | 106° ø35 | 106° ø35 | 106° ø35 | 106° ø35 | Packaging Emballage |
|--|----------|----------|----------|----------|------------------------|
| | | | | | |
| s/c | CSP3Y99 | CSP3Z99 | CSP3999 | CSP3899 | 300 |
| s/c | CSR3Y99 | CSR3Z99 | CSR3999 | CSR3899 | 300 |
| | | | | | |
| Suggested frame fixing screw # 10 x 3/4" RHP. Vis de fixation recommandée pour cadre # 10 x 3/4" RHP. | | | | | |



| | | | | | |
|--|---------|---------|---------|---------|-----|
| s/c | CSP3799 | CSP3699 | CSP3599 | CSP3499 | 300 |
| s/c | CSR3799 | CSR3699 | CSR3599 | CSR3499 | 300 |
| | | | | | |
| Zero-door protrusion - Suggested frame fixing screw # 10 x 3/4" RHP. Sans recul de la porte - Vis de fixation recommandée pour cadre # 10 x 3/4" RHP. | | | | | |



| | | | | | |
|--|----------|----------|----------|----------|-----|
| s/c | CSP3299N | CSP3199N | CSP3A99N | CSP3B99N | 300 |
| s/c | CSR3299N | CSR3199N | CSR3A99N | CSR3B99N | 300 |
| | | | | | |
| Zero-door protrusion - Suggested frame fixing screw # 10 x 1" RHP. Sans recul de la porte - Vis de fixation recommandée pour cadre # 10 x 1" RHP. | | | | | |

| | | | | | |
|--|----------|----------|----------|--|-----|
| s/c | CSP3C99N | CSP3D99N | CSP3E99N | | 300 |
| s/c | CSR3C99N | CSR3D99N | CSR3E99N | | 300 |
| | | | | | |
| Zero-door protrusion - Suggested frame fixing screw # 10 x 3/4" RHP. Sans recul de la porte - Vis de fixation recommandée pour cadre # 10 x 3/4" RHP. | | | | | |

Adjustments

Réglages

Zero-door protrusion from $\frac{1}{2}$ " to $1 - \frac{9}{16}$ " overlay.
 Sans recul de la porte, recouvrement de $\frac{1}{2}$ " à $1 - \frac{9}{16}$ ".

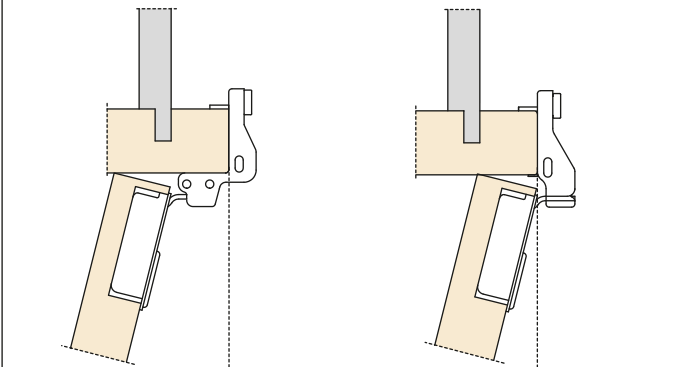

D = required door overlay
T = max. door thickness
K = drilling distance
A = reveal
L = gap between door and frame

- Stamped steel
- Cup depth 11 mm ($\frac{7}{16}$ ")
- Opening 106° degrees
- K fixed at 2.5 mm ($\frac{3}{32}$ ")
- L = 4.6 mm ($\frac{3}{16}$ ")
- **For overlays from $\frac{1}{4}$ " through $\frac{3}{4}$ " the "A" value = 8.3 mm for $\frac{3}{4}$ " square edge doors at 90° opening.**
- **For overlays from 1" through $1 - \frac{7}{16}$ " the "A" value = 5.2 mm for $\frac{3}{4}$ " square edge doors at 90° opening.**

Frame cabinet.
 Meuble avec cadre.

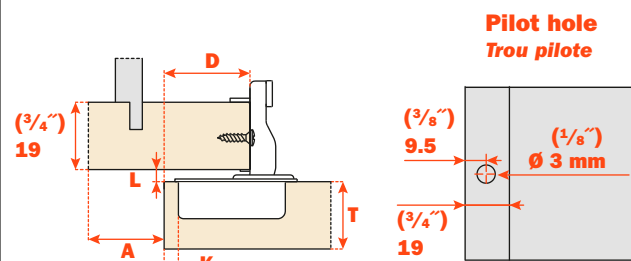

D = recouvrement désiré
T = épaisseur max. de la porte
K = distance de perçage
A = jeu
L = distance entre la porte et le cadre

- Acier moulé
- Profondeur du boîtier 11 mm ($\frac{7}{16}$ ")
- Ouverture à 106°
- K fixé à 2,5 mm ($\frac{3}{32}$ ")
- L = 4.6 mm ($\frac{3}{16}$ ")
- **Pour les recouvrements de $\frac{1}{4}$ " à $\frac{3}{4}$ " , la valeur « A » = 8.3 mm pour les portes à bord carré de $\frac{3}{4}$ " à 90° d'ouverture.**
- **Pour les recouvrements de 1" à $1 - \frac{7}{16}$ " , la valeur "A" = 5.2 mm pour les portes à bord carré de $\frac{3}{4}$ " à 90° d'ouverture.**

Height adjustment ± 2 mm ($\pm \frac{3}{32}$ ")

Réglage vertical ± 2 mm ($\pm \frac{3}{32}$ ")

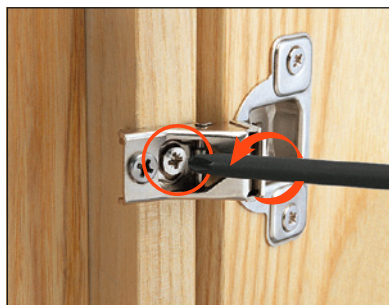
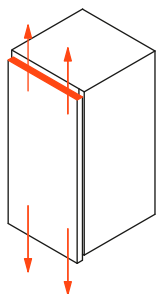

Depth adjustment by eccentric cam
 $+2.5$ mm ($+\frac{7}{64}$ "), -0.5 mm ($-\frac{1}{64}$ ")

Réglage frontal par vis excentrique
 $+2.5$ mm ($+\frac{7}{64}$ "), -0.5 mm ($-\frac{1}{64}$ ")

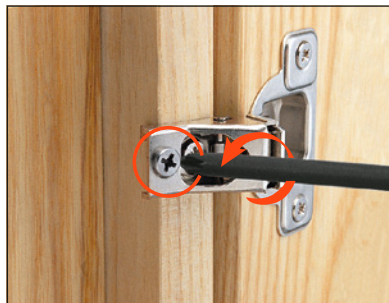
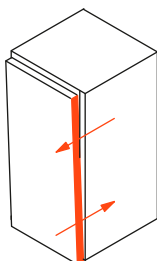

Side adjustment by eccentric cam for hinges:

- CS_3Y99; CS_3Z99; CS_3999; CS_3899; CS_3799; CS_3699;
 CS_3599; CS_3499,
 $+2.8$ mm, -1.5 mm ($+\frac{7}{64}$ " , $-\frac{1}{16}$ ")

- CS_3299N; CS_3199N; CS_3A99N; CS_3B99N; CS_3C99N;
 CS_3D99N; CS_3E99N;
 $+3$ mm, -2 mm ($+\frac{1}{8}$ " , $-\frac{5}{64}$ ")

Réglage latéral par vis excentrique pour charnières:

- CS_3Y99; CS_3Z99; CS_3999; CS_3899; CS_3799; CS_3699;
 CS_3599; CS_3499,
 $+2.8$ mm, -1.5 mm ($+\frac{7}{64}$ " , $-\frac{1}{16}$ ")

- CS_3299N; CS_3199N; CS_3A99N; CS_3B99N; CS_3C99N;
 CS_3D99N; CS_3E99N;
 $+3$ mm, -2 mm ($+\frac{1}{8}$ " , $-\frac{5}{64}$ ")

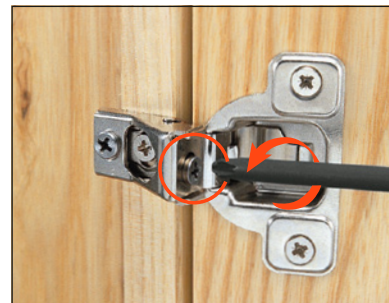
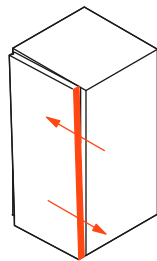

S series **ecen three** **3 cam adjustable**
Serie S **3 vis excentriques réglables**

| | | | | | |
|--|----------|----------|----------|----------|------------------------|
| | 106° ø35 | 106° ø35 | 106° ø35 | 106° ø35 | Packaging Emballage |
| | | | | | |

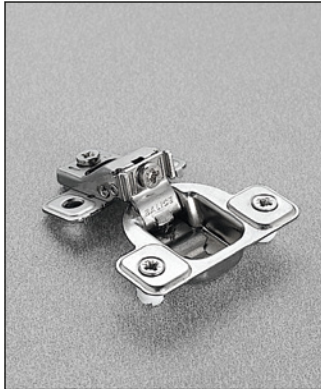

| | | | | | |
|---|-----------|-----------|-----------|-----------|-----|
| s/c | CSP3799XR | CSP3699XR | CSP3599XR | CSP3499XR | 300 |
| s/c | CSR3799XR | CSR3699XR | CSR3599XR | CSR3499XR | 300 |
| | | | | | |
| Zero-door protrusion - Suggested frame fixing, screw # 6 x 5/8" FHP. Sans recul de la porte - Vis de fixation recommandée pour cadre # 6 x 5/8" FHP. | | | | | |



| | | | | | |
|---|-----------|-----------|-----------|-----------|-----|
| s/c | CSP3299NR | CSP3A99NR | CSP3B99NR | CSP3C99NR | 300 |
| s/c | CSR3299NR | CSR3A99NR | CSR3B99NR | CSR3C99NR | 300 |
| | | | | | |
| Zero-door protrusion - Suggested frame fixing, screw # 6 x 5/8" FHP. Sans recul de la porte - Vis de fixation recommandée pour cadre # 6 x 5/8" FHP. | | | | | |

Ideal for refacing and other applications where frame thickness varies. Hinge is indexed from the front of the face frame only. There is no back tab.

Idéal pour les rénovations et autres applications où l'épaisseur du cadre varie. La charnière est insérée uniquement dans la partie avant du cadre. Pas de butée arrière.

| | | | | | |
|---|-----------|-----------|--|--|-----|
| s/c | CSP3D99NR | CSP3E99NR | | | 300 |
| s/c | CSR3D99NR | CSR3E99NR | | | 300 |
| | | | | | |
| Zero-Door Protrusion - Suggested frame fixing, screw # 6 x 5/8" FHP. Sans recul de la porte - Vis de fixation recommandée pour cadre # 6 x 5/8" FHP. | | | | | |

Adjustment Réglages

Zero-door protrusion from $\frac{1}{2}$ " to $1 - \frac{9}{16}$ " overlay
 Sans recul de la porte, recouvrement de $\frac{1}{2}$ " à $1 - \frac{9}{16}$ "

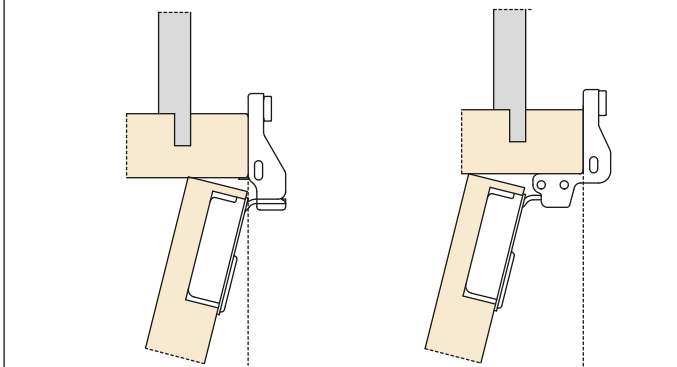

- D** = required door overlay
- T** = max. door thickness
- K** = drilling distance
- A** = reveal
- L** = gap between door and frame

- Stamped steel
- Cup depth 11 mm ($\frac{7}{16}$ ")
- Opening 106°
- K fixed at 2.5 mm ($\frac{3}{32}$ ")
- L = 4.6 mm ($\frac{3}{16}$ ")

- **For overlays from $\frac{1}{2}$ " through $\frac{3}{4}$ " the "A" value = 8.3 mm for $\frac{3}{4}$ " square edge doors at 90° opening.**
- **For overlays from 1" through $1 - \frac{7}{16}$ " the "A" value = 5.2 mm for $\frac{3}{4}$ " square edge doors at 90° opening.**

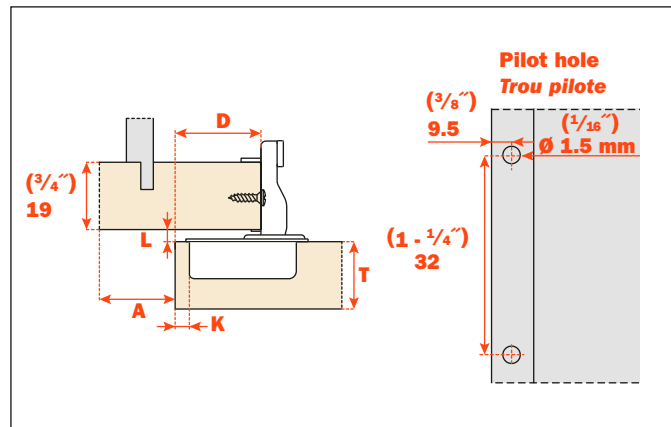

- D** = recouvrement désiré
- T** = épaisseur max. de la porte
- K** = distance de perçage
- A** = jeu
- L** = distance entre la porte et le cadre

- Acier moulé
- Profondeur du boîtier 11 mm ($\frac{7}{16}$ ")
- Ouverture à 106°
- K fixé à 2,5 mm ($\frac{3}{32}$ ")
- L = 4.6 mm ($\frac{3}{16}$ ")

- **Pour les recouvrements de $\frac{1}{2}$ " à $\frac{3}{4}$ " , la valeur "A" = 8.3 mm pour les portes à bord carré de $\frac{3}{4}$ " à 90° d'ouverture.**
- **Pour les recouvrements de 1" à $1 - \frac{7}{16}$ " , la valeur "A" = 5.2 mm pour les portes à bord carré de $\frac{3}{4}$ " à 90° d'ouverture.**

Height adjustment by eccentric cam ± 2 mm ($\pm \frac{3}{32}$ ")
 Réglage vertical par vis excentrique ± 2 mm ($\pm \frac{3}{32}$ ")

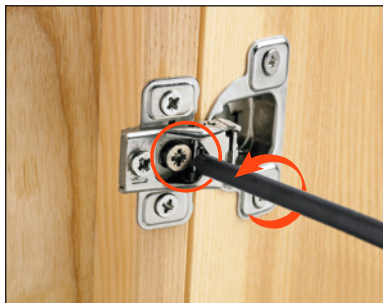
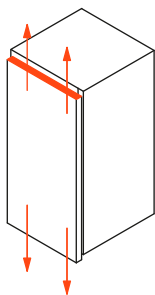

Depth adjustment by eccentric cam
-0.5 mm ($-\frac{1}{64}$ ") +2.5 mm ($+\frac{7}{64}$ ")
 Réglage frontal par vis excentrique
-0.5 mm ($-\frac{1}{64}$ ") +2.5 mm ($+\frac{7}{64}$ ")

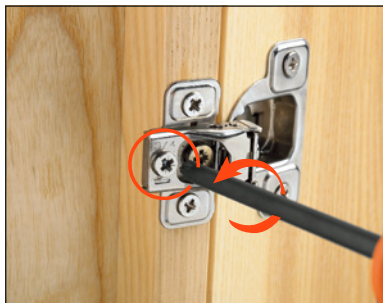
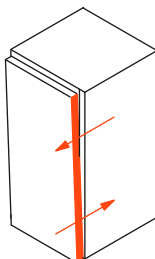

Side adjustment by eccentric cam for hinges:

- CS_3799XR; CS_3699XR; CS_3599XR; CS_3499XR,
+2.8 mm, -1.5 mm ($+\frac{7}{64}$ " , $\frac{1}{16}$ ")
- CS_3299NR; CS_3A99NR; CS_3B99NR; CS_3C99NR; CS_3D99NR;
 CS_3E99NR;
+3 mm, -2 mm ($+\frac{1}{8}$ " , $-\frac{5}{64}$ ")

Réglage latéral par vis excentrique pour charnières:

- CS_3799XR; CS_3699XR; CS_3599XR; CS_3499XR,
+2.8 mm, -1.5 mm ($+\frac{7}{64}$ " , $-\frac{1}{16}$ ")
- CS_3299NR; CS_3A99NR; CS_3B99NR; CS_3C99NR; CS_3D99NR;
 CS_3E99NR;
+3 mm, -2 mm ($+\frac{1}{8}$ " , $-\frac{5}{64}$ ")

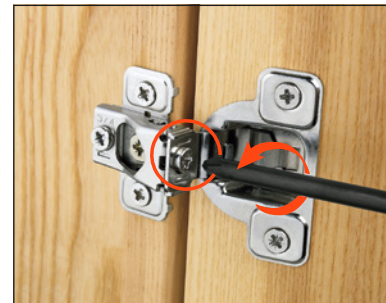
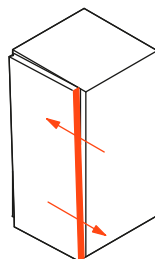

Accessories Accessoires

S2BX83H9



Steel symmetrical screw cover cap with or without printed logo.
For all 100, 200 and F hinges.
5.000 pcs/box.
Minimum order for personalized cover cap is 10.000 pcs.
Excluded: 165° and 155° opening hinges.

Cache-vis symétrique en acier avec ou sans logo imprimé.
Pour les charnières Série 100, 200 et F.
5.000 pièces/carton.
Commande minimum pour un cache-vis avec personnalisation: 10.000 pièces.
Exclus : charnières à ouverture 165° et 155°.

S2MX83H9



Steel symmetrical screw cover cap with embossed logo.
For all 100, 200 and F hinges.
5.000 pcs/box.
Minimum order for personalized cover cap is 100.000 pcs.
Excluded: 165° and 155° opening hinges.

Cache-vis symétrique en acier avec logo gravé.
Pour les charnières Série 100, 200 et F.
5.000 pièces/carton.
Commande minimum pour un cache-vis avec personnalisation: 100.000 pièces.
Exclus : charnières à ouverture 165° et 155°.

S2XX83A1



Nylon symmetrical screw cover cap with or without printed logo.
For all 100, 200 and F hinges.
Available in white, gray and black. 5.000 pcs/box.
Minimum order for personalized cover cap is 10.000 pcs. Excluded: 165° and 155° opening hinges.

Cache-vis symétrique en nylon avec ou sans logo imprimé.
Pour les charnières Série 100, 200 et F.
Disponible en blanc, gris et noir.
5.000 pièces/carton.
Commande minimum pour un cache-vis avec personnalisation: 10.000 pièces.
Exclus : charnières à ouverture 165° et 155°.

SSXX83



Nylon asymmetrical screw cover cap with or without printed logo.
For all S series hinges. Available in beige and gray. 5.000 pcs/box.
Minimum order for personalized cover cap is 10.000 pcs.
For further information please consult our technical support department.

Cache-vis asymétrique en nylon avec ou sans logo imprimé.
Pour les charnières Série S.
Disponible en beige et gris.
5.000 pièces/carton.
Commande minimum pour un cache-vis avec personnalisation: 10.000 pièces.
Pour toutes les explications, veuillez consulter notre service d'assistance technique.

Steel Flange Cache-boîtier en acier



S2XX85H9
Steel flange cover cap, it can be personalized on request.

S2XX85H9
Cache-boîtier en acier.
Personnalisation (logo) sur demande.

S2CX85H9
Steel flange cover cap with embossed logo.

S2CX85H9
Cache-boîtier en acier avec logo gravé.

S2AF37X3



Reduction clip for 165° hinges:
limits opening to 120°.
Reduction clip for 155° hinges:
limits opening to 140°.
Black.

*Arrêt pour les charnières à
165°, pour limiter l'ouverture
à 120°.
Arrêt pour les charnières à
155°, pour limiter l'ouverture
à 140°.
Noir*



SBA237XG

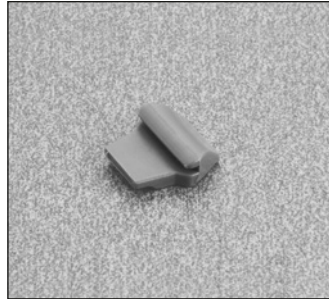

Reduction clip for Universal
hinges: limits opening to 90°

Arrêt à 90° pour toutes les
charnières Universelles.



S2BF37XY

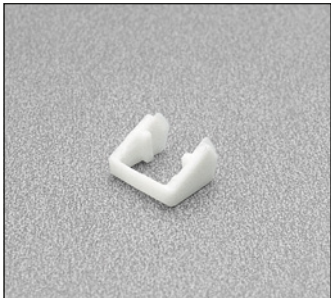

Reduction clip for 165° hinges:
limits opening to 115°.
Reduction clip for 155° hinges:
limits opening to 135°.
White.

*Arrêt pour les charnières à 165°,
pour limiter l'ouverture à 115°.
Arrêt pour les charnières à 155°,
pour limiter l'ouverture à 135°.
Blanc*

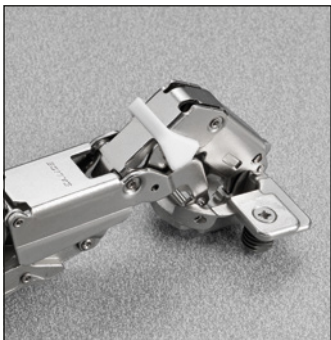

S2A637XF



Reduction clip for all hinges with
94° opening and 35 mm cup only.
Limits opening to 86°.

500 pcs/box.

*Arrêt à 86° pour toutes les
charnières à 94° avec boîtier
ø 35 mm.
500 pièces/carton.*



**Accessories
Accessoires**

SSP3377G



Reduction clip for partial overlay
S series hinges from 1/4" - 3/4".
Limits opening to 86°.

*Arrêt à 86° pour les charnières
Série S, recouvrement
partiel, de 1/4" - 3/4".
Limite l'ouverture à 86°.*



SSP337AG



Reduction clip for full overlay
S series hinges from 1" to 1-1/2".
Limits opening to 86°.

*Arrêt à 86° pour les charnières
Série S, recouvrement
partiel, de 1" to 1-1/2".
Limite l'ouverture à 86°.*



S2BM37XG

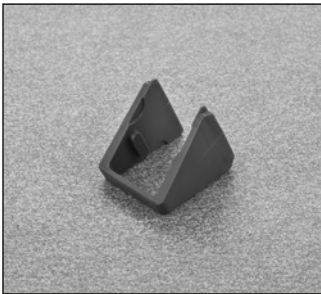

For 155° hinges,
it limits opening to 92°.

*Pour limiter l'ouverture à 92°
pour les charnières à 155°.*



S2AM37XG



For 155° hinges,
it limits opening to 120°.

*Pour limiter l'ouverture à 120°
pour les charnières à 155°.*

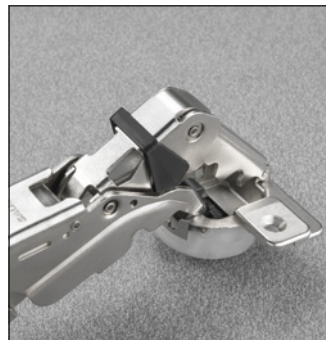



Push - self opening hinge system
Push - système de charnières à ouverture automatique

Push

Push - Self opening door system allows for easy and complete opening of cabinet and furniture doors by lightly pressing on the door itself. Manufacturers will be able to implement the use of Push into the design of contemporary units free of decorative hardware.

Push - Le système pour l'ouverture automatique de toutes sortes de meubles sans poignée, en appuyant légèrement sur la porte. Les fabricants pourront mettre en oeuvre l'utilisation de Push dans la conception d'unités contemporaines sans quincaillerie décorative



The Push system is composed of three components cooperating to swing the door open automatically:

- 1) Multiple self opening hinges**
- 2) One latch**
- 3) One catch**

Le système Push est composé de trois composants pour ouvrir la porte automatiquement:

- 1) Charnières avec poussée en ouverture**
- 2) Un loqueteau**
- 3) Un gâche**

To select the correct number of hinges please refer to the chart on page 4 of this catalog.

Pour sélectionner le nombre correct de charnières, veuillez-vous reporter au tableau de la page 4 de ce catalogue.

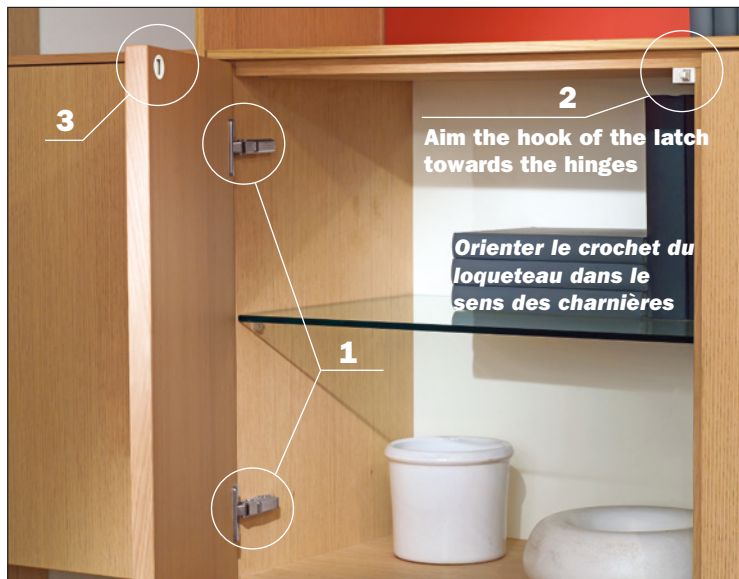

“PUSH has been designed to function without the need of finger pulls (i.e. back bevel doors, routed finger pulls, etc.) and decorative hardware such as pulls, knobs, etc. Forcing the door open could damage the push mechanism.”

“PUSH a été projeté pour l'ouverture de toutes sortes de meubles sans poignées, boutons ou autres accessoires décoratifs (dans les portes moulées ou avec biseaux de tous les côtés). Forcer la porte pourrait endommager le mécanisme Push”.



DP3SNB - beige - beige

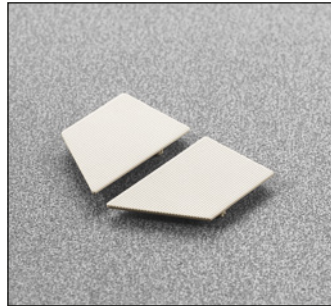
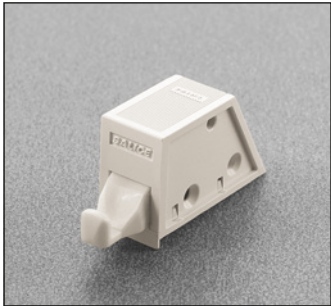

**PUSH - for woodscrew fixing.
With assembly stop tabs.**

**PUSH - fixation avec vis à bois
Avec butée.**

**Packing - 300
Emballage - 300**

DP3SNG - gray - gris

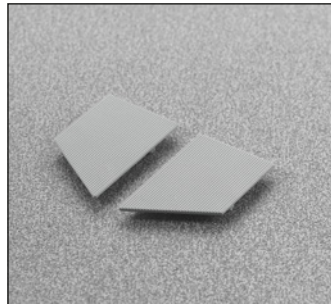
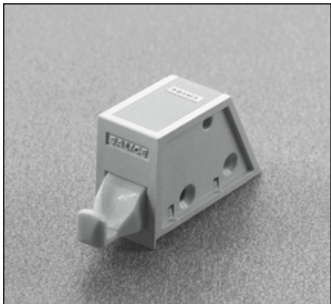

**PUSH - for woodscrew fixing.
With assembly stop tabs.**

**PUSH - fixation avec vis à bois
Avec butée.**

**Packing - 300
Emballage - 300**

DP3SN3 - black - noir

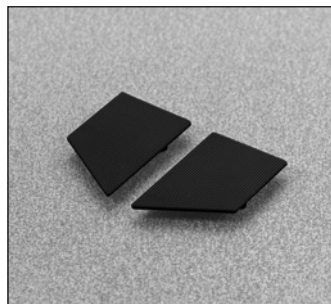
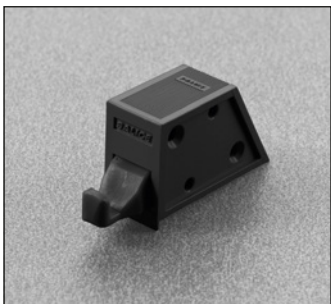

**PUSH - for woodscrew fixing.
With assembly stop tabs.**

**PUSH - fixation avec vis à bois
Avec butée.**

**Packing - 300
Emballage - 300**

DP29SNB - beige - beige



DP29SNG - gray - gris

DP29SN3 - black - noir

**Retaining catch for wood door.
For overlay applications.**

Knock-in.
Requires 26 mm hole.

**Gâche pour porte en bois.
Pour porte en applique.**

A pression.
Perçage 26 mm.

**Packing - 300
Emballage - 300**

DP29SNBR - beige - beige



DP29SNGR - gray - gris

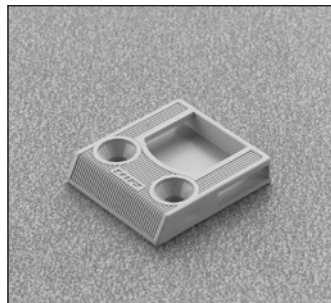

DP29SN3R - black - noir

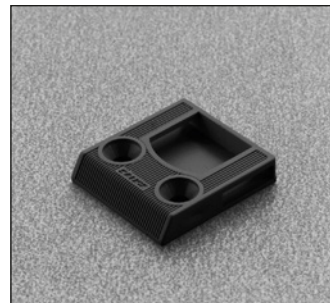

**Retaining catch for wood door.
For inset applications.**

Without assembly stop tabs.
Screw-on.

**Gâche pour porte en bois.
Pour porte rentrante**

Sans butée.
A visser.

**Packing - 300
Emballage - 300**

Push

DP4SNB - beige - beige

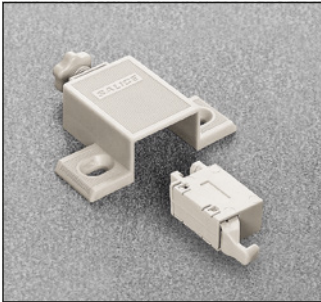

DP4SNG - gray - gris

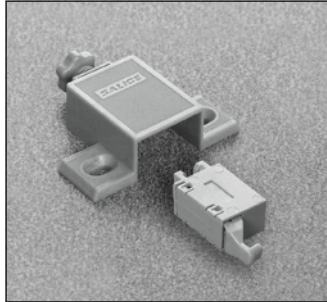

DP4SN3 - black - noir

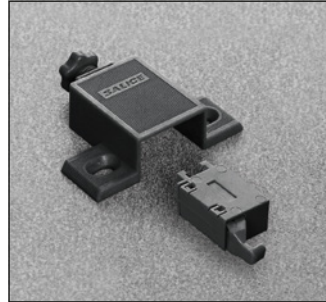

PUSH with adjustment

Single adapter with lateral and depth adjustment including release device (latch). Without assembly stop tabs.

PUSH avec réglage

Adaptateur simple avec réglage frontal et latéral et loqueteau. Sans butée.

Packing - 300

Emballage - 300

DP5SNB - beige - beige

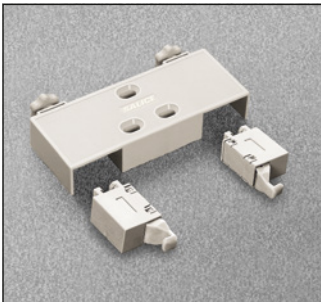

DP5SNG - gray - gris

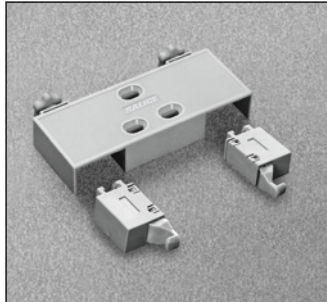

DP5SN3 - black - noir



PUSH with adjustment

Double adapter with lateral and depth adjustment including release device (latch). Without assembly stop tabs.

PUSH avec réglage

Adaptateur double avec réglage frontal et latéral et loqueteaux. Sans butée.

Packing - 150

Emballage - 150



Technical information on the adjustable Push

The adjustable Push consists of a release device (latch) and a screw-fixed adapter which has been developed to improve the locating action of the system. It now has a depth adjustment series of -1 mm to + 2.5 mm which is controlled by a small adjuster screw located at the back of the adapter. In addition, the adapter has a lateral adjustment of ± 2 mm series. This is achieved by loosening the two fixing screws and adjusting the position of the adapter using the elongated holes. Finally, the screws must be retightened.

Caractéristiques techniques Push mécanique avec réglage.

Le PUSH avec réglage, composé d'un loqueteau et d'un adaptateur à visser, a été développé pour résoudre les problèmes d'accrochage entre le loqueteau et gâches (monté sur la porte). Il est possible d'effectuer un réglage frontal de -1 à 2.5 mm en agissant sur la molette de l'adaptateur. En dévissant les deux vis de fixation, il est possible de régler latéralement le Push de ± 2 mm. Les trous ovales permettent le glissement de l'adaptateur dans les deux sens. Une fois l'opération terminée, les vis doivent être resserrées.

PUSH Insertion tool for retaining catch.

Salice America offers a 26 mm drill bit - TDB5726R.

PUSH Outil pour gâche

Salice America offre un foret de 26 mm - TDB5726R.

DP50SNO



Oseries insertion tool for aligning the retaining catch DP29SNX.

Outil orange pour régler la position de gâches DP29SNX.

Drilling for wood doors
Perçage pour portes en bois



Full-overlay door
Porte en applique

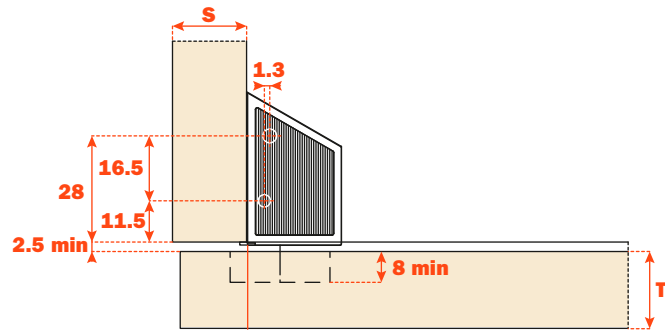
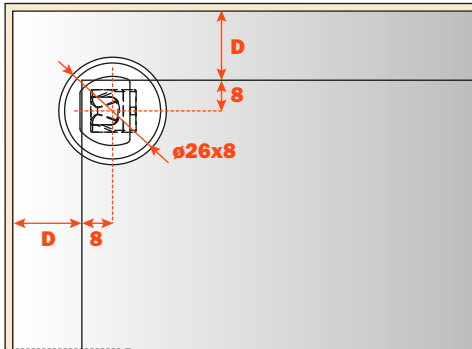

D = Door overlay on side and top of the cabinet
Drilling distance to the center of retaining catch = D + 8

D = Recouvrement de la porte sur le côté et le chapeau haut du meuble
Distance de perçage de gâches = D + 8

Inset door
Porte rentrante

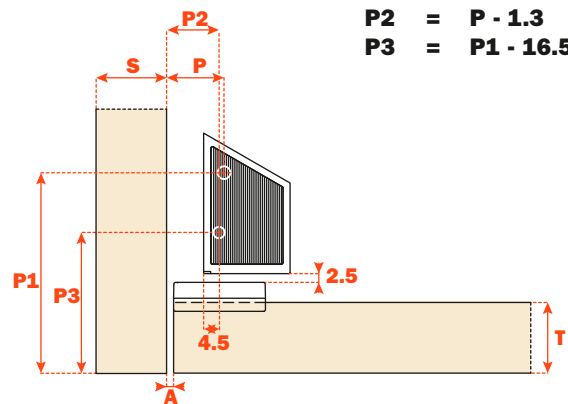
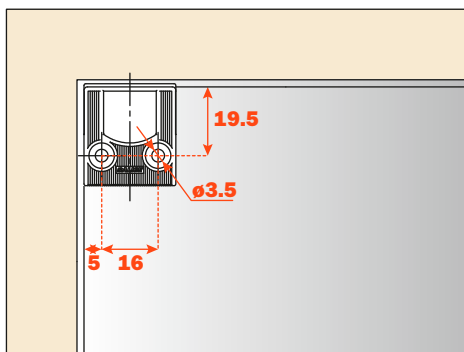

$$\begin{aligned}
 P &= 14.8 + A \\
 P1 &= 36.8 + T \\
 P2 &= P - 1.3 \\
 P3 &= P1 - 16.5
 \end{aligned}$$

Salice America offers 4.8 mm spacer (left and right) for special inset doors applications; refer to our master catalog for descriptions, item numbers and packaging.

Salice America offre une cache de 4,8 mm (gauche et droite) pour les applications spéciales avec porte rentrante; voir notre catalogue général pour les descriptions, les codes et les emballages.

Push • With adjustment

Push • Avec réglage

Push with depth and lateral adjustment

Push avec réglage frontal et latéral

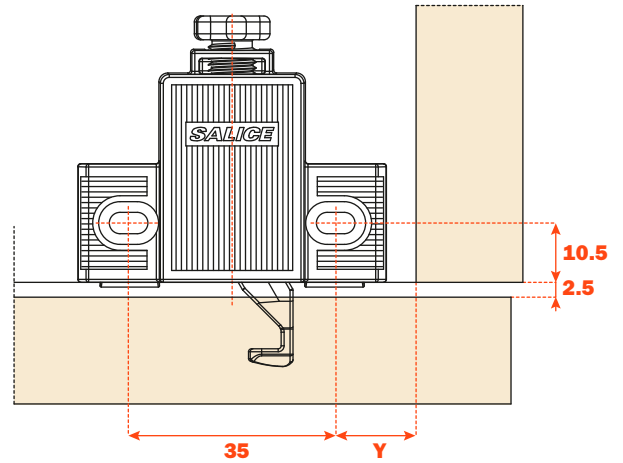
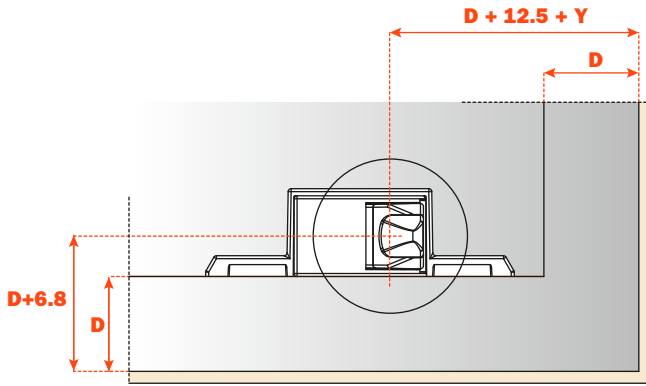

D = Door overlay on side and top of the cabinet
Y = min. 8.5 mm

D = Recouvrement de la porte sur le côté et le chapeau haut du meuble
Y = min. 8.5 mm

Double Push with depth and lateral adjustment

Push double avec réglage frontal et latéral

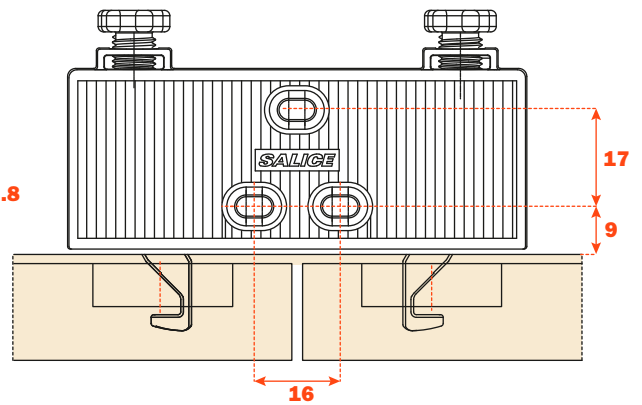
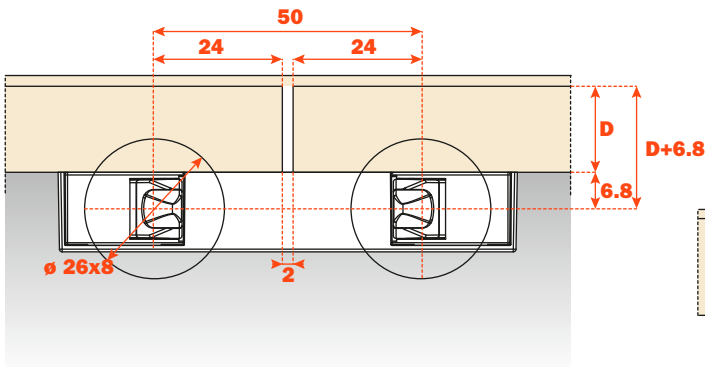

Magnetic release device
Loqueteau magnétique



DPMSNB



Release device.
ø 10 mm, 40 mm length.

Loqueteau.
ø 10 mm, longueur 40 mm.

Packing - 250

Emballage - 250

DPASNB



Magnetic device to be used to increase the magnetic holding strength. It must always be used together with the DPM. The suggested position of the DPM is the point of pressure on the door. The DPA can be positioned at any point along the opening edge of the door. ø 10 mm, 40 mm length.

Crochet magnétique à utiliser pour augmenter la force de retenue. Il doit être toujours utilisé en combinaison avec le DPM. La position conseillée du DPM est en correspondance avec le point de pression sur la porte. Celle du DPA est indifférente. 10 mm, longueur 40 mm.

Packing - 250

Emballage - 250

DP28SN9



Retaining catch to be inserted.
ø 11.5 mm.

Gâches à enfoncer.
ø 11.5 mm.

Packing - 250

Emballage - 250

DP38XX91



Retaining catch with adhesive.
20x14 mm.

Gâches avec adhésif.
20x14 mm

Packing - 250

Emballage - 250

DP39XXG

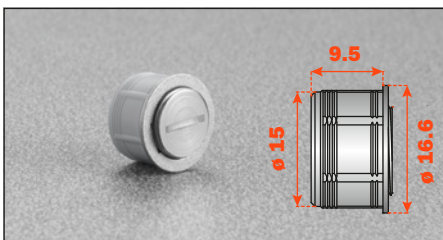

Adjustable magnetic retaining catch.
ø16.6 mm

Platine magnétique réglable.
ø16.6 mm

Packing - 250

Emballage - 250

SP44XX_

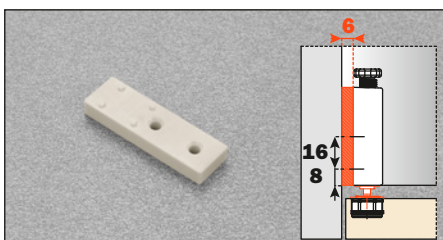

Spacer for inset door to be used together with DP82XX_R.

Cache pour porte rentrante en combinaison avec DP82XX_R.

SP44XXB = Beige
SP44XX3 = Black
SP44XXG = Grey

SP44XXB = Beige
SP44XX3 = Noir
SP44XXG = Gris

Packing - 500

Emballage - 500

Push • Adapters Push • Adaptateurs

DP82XXBR



Adjustable longitudinal plastic adapter for release device. To be fixed with woodscrews. 8+16 mm drilling.

Screw cover to be ordered separately.
DP82xxBR = beige DP82xxQR = brown*
DP82xxGR = gray* DP82xx3R = black

*Brown and gray are non stock and are special order.

Note: The cover cap shown in the picture has to be ordered separately

Packing - 500

Adaptateur longitudinal réglable, en plastique, pour loqueteau. Fixation avec vis à bois.

Perçage 8+16 mm.

Cache à commander à part.

DP82xxBR = beige DP82xxQR = marron*
DP82xxGR = gris* DP82xx3R = noir

*Marron et gris ne sont pas en stock et sont commandes spéciales.

Note: la cache sur l'adaptateur dans la photo doit être commandé séparément

Emballage - 500

DP83XXBR

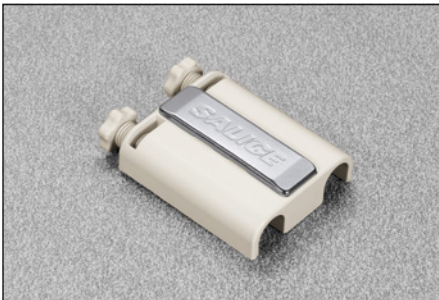

Adjustable double plastic adapter for release device.

To be fixed with woodscrews.

8+32 mm drilling.

Screw cover to be ordered separately.
DP83xxBR = beige DP83xxQR = brown*
DP83xxGR = gray* DP83xx3R = black

*Brown and gray are non stock and are special order.

Note: The cover cap shown in the picture has to be ordered separately

Packing - 500

Adaptateur double réglable, en plastique, pour loqueteau. Fixation avec vis à bois.

Perçage 8+32 mm.

Cache à commander à part.

DP83xxBR = beige DP83xxQR = marron*
DP83xxGR = gris* DP83xx3R = noir

*Marron et gris ne sont pas en stock et sont commandes spéciales.

Note: la cache sur l'adaptateur dans la photo doit être commandé séparément

Emballage - 500

DP84SNBR



Adjustable plastic adapter for release device. To be fixed with woodscrews.

8x32 mm drilling.

DP84xxBR = beige DP84xxQR = brown*
DP84xxGR = gray* DP84xx3R = black

*Brown and gray are non stock and are special order.

Packing - 500

Adaptateur réglable, en plastique, pour loqueteau. Fixation avec vis à bois.

Perçage 8x32 mm.

DP84xxBR = beige DP84xxQR = marron*
DP84xxGR = gris* DP84xx3R = noir

*Marron et gris ne sont pas en stock et sont commandes spéciales.

Emballage - 500

Release device application

Application du loqueteau



Release device application with adapter (DP82xxBR) without assembly stop devices.

Insert the release device frontally into the adapter.
Place the adapter to the top, the side or the base panel of the cabinet, using the drilling value of 8+16 mm for final positioning.

*Release device application with spacer for inset door (DP82SN_R + SP44XX_).

For inset door it is essential to use the spacer SP44XX_.

Application du loqueteau avec adaptateur (DP82xxBR) sans butées.

Insérer frontalement le loqueteau dans l'adaptateur. Fixer l'adaptateur sur le chapeau haut, le côté ou la base du meuble, en considérant, pour le positionnement correct, la valeur d'entraxe 8+16 mm.

Application du loqueteau avec cache pour porte rentrante (DP82SN_R + SP44XX_).

Pour porte rentrante il est nécessaire d'ajouter le cache SP44XX_.

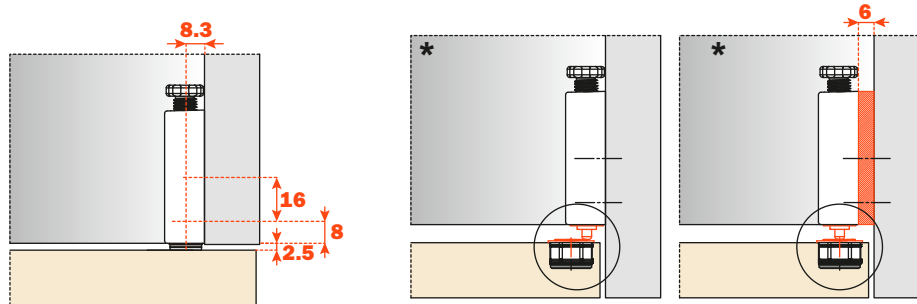

Release device application with adapter (DP83xxBR) without assembly stop devices.

Insert the release device into the adapter.
Attach the adapter to the top, the side or the base panel of the cabinet, using the drilling value of 8+32 mm for accurate positioning.

Application du loqueteau avec adaptateur (DP83xxBR) sans butées.

Insérer frontalement le loqueteau dans l'adaptateur. Fixer l'adaptateur sur le chapeau haut, le côté ou la base du meuble, en considérant, pour le positionnement correct, la valeur d'entraxe 8+32 mm.

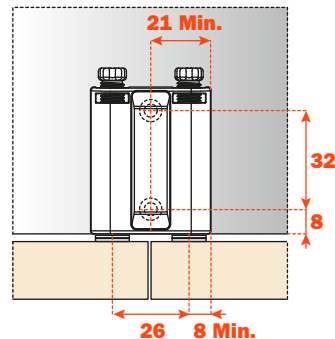

Release device application with adapter (DP84SN_R) with assembly stop devices.

Insert the release device into the adapter.
Attach the adapter to the top, the side or base panel of the cabinet, using the assembly stop devices for accurate positioning.

Application du loqueteau avec adaptateur (DP84SN_R) avec butées.

Insérer le loqueteau dans l'adaptateur. Fixer l'adaptateur sur le chapeau haut, le côté ou la base du meuble, en utilisant les butées pour le positionnement correct.

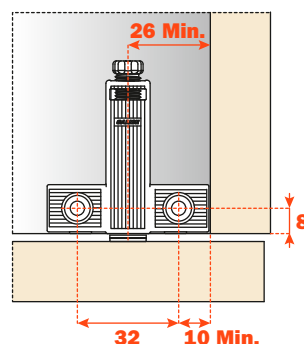

Push • Release device application**Push • Application du loqueteau****Application of the release device to be recessed.**

Drill a hole \varnothing 10 mm and min. 40 mm deep in the top, side or base panel of the cabinet.

Insert the release device into the hole.

Application du loqueteau à encastrer

Percer un trou de 10 mm de diamètre et min. 40 mm de profondeur dans le chapeau, le côté ou la base du meuble. Insérer le loqueteau dans le trou.

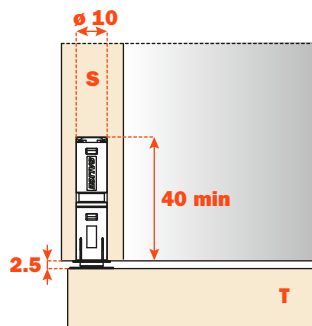



1 - Retaining catch with adhesive.

Apply the retaining catch to the magnetic release device.
Refer to Figure 1 below. Remove the protective covering from the adhesive and center the catch on the release device.
Close the door and apply firm pressure so that the retaining catch will then be correctly positioned on the door.
Reopen the door and again apply pressure to the catch to secure the bond.

Attention:

For a correct application and to insure optimum performance, we suggest that you carefully follow the guidelines listed below.

- 1 - Clean and degrease the door surface where the retaining catch is to be installed.
- 2 - Remove the protective covering from the adhesive
- 3 - Place the retaining catch in position, while in an environment where the temperature is 50° F or above. Apply firm pressure for 10-15 seconds after which the catch is suitable for use. Maximum bond is attained in 24 hrs.

1

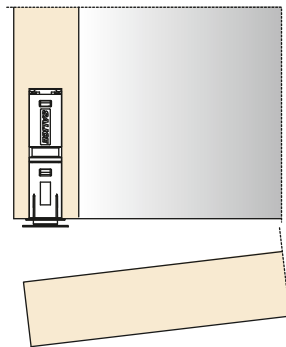

1 - Platine avec adhésif

Appliquer platine au loqueteau magnétique. Reportez-vous à la figure 1 ci-dessous.
Ôter la bande de protection de l'adhésif.
Fermer la porte.
Platine adhésif est ainsi positionné sur la porte.
Rouvrir la porte et appuyer fortement sur platine pour une application correcte.

ATTENTION :

Pour une application correcte et afin d'assurer une meilleure tenue dans le temps, il est conseillé de suivre les instructions suivantes :

- 1 - nettoyer et dégraisser la surface de la porte sur laquelle platine adhésif doit être appliqué;
- 2 - ôter la bande de protection de l'adhésif ;
- 3 - appliquer platine dans un lieu avec température ambiante >10° et appuyer pendant 10 à 15 secondes environ. Quelques secondes après l'application, platine est prêt à l'emploi. Après 24h, on atteint la tenue maximum.

2 - Retaining catch to be inserted.

Apply and center the retaining catch on the magnetic release device.
Refer to Figure 2 below.
Close the door, which in turn, will create an indentation in the door marking the location where the catch is to be inserted.
Using a small hammer, carefully tap in the catch using the indentation as the locating point for positioning. It is then ready for immediate use.

2

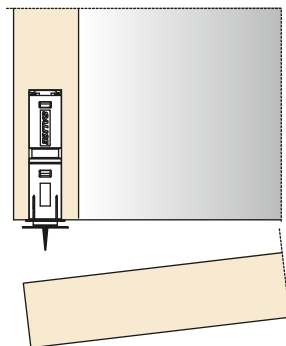

2 - Platine à enfoncer



Appliquer platine au loqueteau magnétique.
Reportez-vous à la figure 2 ci-dessous.
Fermer la porte.
La pointe de platine indiquera l'endroit où l'on doit l'insérer.
Rouvrir la porte et insérer par pression platine.
À l'aide d'un petit marteau, tapotez délicatement dans le loquet en utilisant l'indentation comme point de positionnement .
Il est alors prêt pour une utilisation immédiate.

Push • 200 series hinges • 94° for thick doors

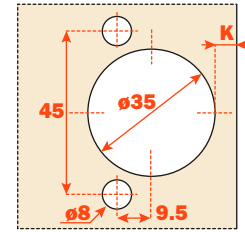

Push • Charnières Série 200 - Pour portes épaisses - Ouverture 94°

| | | |
|--|---|----------------------|
| | 94° ø35 | Packing Emballage |
| |  | |





| | | | |
|-------------|---|---------|-----|
| PUSH |  | C2PVA99 | 300 |
| PUSH |  | C2RVA99 | 300 |



| | | | |
|-------------|---|---------|-----|
| PUSH |  | C2PVG99 | 300 |
| PUSH |  | C2RVG99 | 300 |





| | | | |
|-------------|---|---------|-----|
| PUSH |  | C2PVP99 | 300 |
| PUSH |  | C2RVP99 | 300 |

200 series hinges - 110°
Charnières Série 200 - 110°



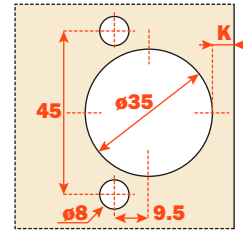

| | | |
|--|---|----------------------|
| | 110° ø35 | Packing Emballage |
| |  | |





| | | | |
|-------------|---|---------|-----|
| PUSH |  | C2PPA99 | 300 |
| PUSH |  | C2RPA99 | 300 |



| | | | |
|-------------|---|---------|-----|
| PUSH |  | C2PPG99 | 300 |
| PUSH |  | C2RPG99 | 300 |





| | | | |
|-------------|---|---------|-----|
| PUSH |  | C2PPP99 | 300 |
| PUSH |  | C2RPP99 | 300 |

Push • 200 series hinges - 155°

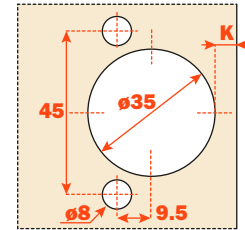

Push • Charnières Série 200 - 155°

| | | |
|--|---|------------------------|
| | 155° ø35 | Packaging Emballage |
| |  | |





| | | | |
|-------------|---|---------|-----|
| PUSH |  | C2PRA99 | 100 |
| PUSH |  | C2RRA99 | 100 |



| | | | |
|-------------|---|---------|-----|
| PUSH |  | C2PRG99 | 100 |
| PUSH |  | C2RRG99 | 100 |





| | | | |
|-------------|---|---------|-----|
| PUSH |  | C2PRP99 | 100 |
| PUSH |  | C2RRP99 | 100 |

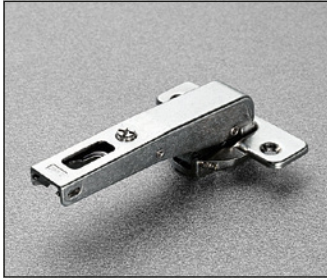
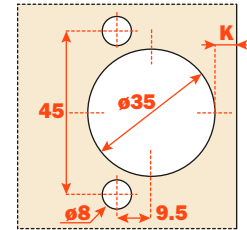

200 series hinges - Complementary hinges
Charnières Série 200 - Charnières complémentaires

| | | |
|--|---|------------------------|
| | 94° ø35 | Packaging Emballage |
| |  | |



| | | |
|---|-----------|-----|
| PUSH  | C2PVN99AC | 150 |
| PUSH  | C2RVN99AC | 150 |



| | | |
|---|---------|-----|
| PUSH  | C2PVN99 | 150 |
| PUSH  | C2RVN99 | 150 |

Compatible with all traditional Series 200 mounting plates, 28x32 mm drilling.
NOT COMPATIBLE with Domi snap-on mounting plates.



Adaptables à toutes les embases traditionnelles Série 200, perçage 28x32 mm.
NON ADAPTABLES aux embases Domi à fixation rapide.

B2S3B99B6/15

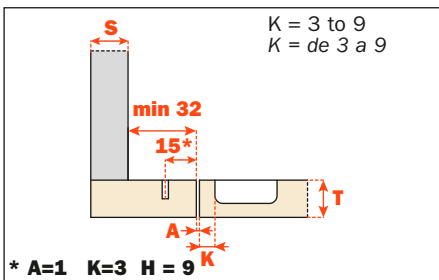

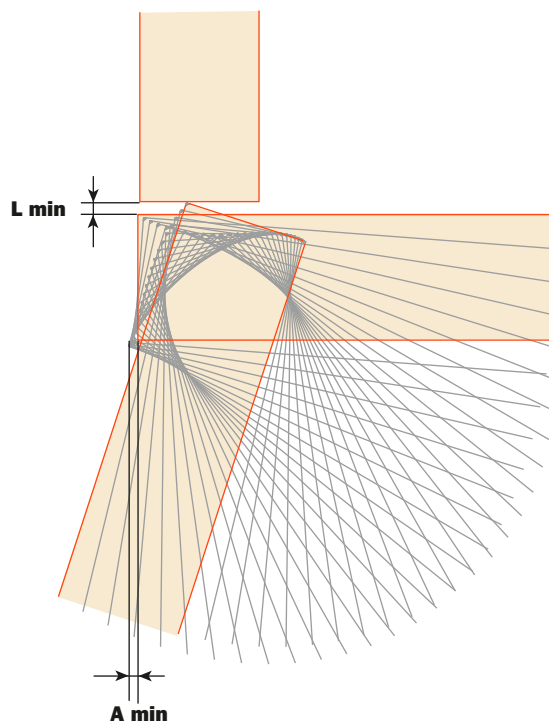

Minimum reveal charts

Tableaux avec jeu nécessaire pour l'ouverture de la porte

Space needed to open the door
Jeu nécessaire pour l'ouverture de la porte

Projection of the door
 Projection of the door from the cabinet side at the maximum opening. The figures are based on a straight arm hinge, H=0 mm thickness of mounting plate and K value = 3 mm.

Recul de la porte
 Recul de la porte par rapport au côté en position d'ouverture maximum (valeur obtenue avec une charnière bras droit, hauteur de l'embase H=0 et valeur K=3)

200 series • 94° - for thicker doors
Space needed to open the door

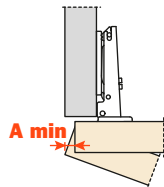

Série 200 • 94° - pour portes épaisses
Jeu nécessaire pour l'ouverture de la porte

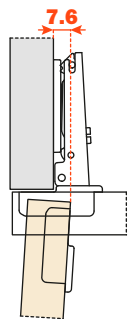

| | T= | 19 | 20 | 21 | 22 | 23 | 24 | 25 | 26 | 27 | 28 | 29 | 30 | 31 | 32 | 33 | 34 | 35 |
|-----|-----------|-----|-----|-----|-----|-----|-----|-----|-----|-----|-----|-----|-----|-----|-----|-----|-----|-----|
| K=3 | A= | 0.1 | 0.2 | 0.3 | 0.4 | 0.5 | 0.7 | 0.8 | 1.0 | 1.6 | 2.6 | 3.5 | 4.5 | 5.4 | 6.4 | 7.4 | 8.3 | 9.3 |
| K=4 | A= | 0.1 | 0.2 | 0.3 | 0.4 | 0.5 | 0.7 | 0.8 | 1.0 | 1.2 | 1.9 | 2.8 | 3.8 | 4.7 | 5.7 | 6.6 | 7.6 | 8.6 |
| K=5 | A= | 0.1 | 0.2 | 0.3 | 0.4 | 0.5 | 0.7 | 0.8 | 1.0 | 1.2 | 1.4 | 2.2 | 3.1 | 4.1 | 5.0 | 5.9 | 6.9 | 7.8 |
| K=6 | A= | 0.1 | 0.2 | 0.3 | 0.4 | 0.5 | 0.6 | 0.8 | 1.0 | 1.2 | 1.4 | 1.7 | 2.6 | 3.5 | 4.4 | 5.3 | 6.2 | 7.2 |
| K=7 | A= | 0.1 | 0.2 | 0.3 | 0.4 | 0.5 | 0.6 | 0.8 | 1.0 | 1.1 | 1.3 | 1.6 | 2.1 | 3.0 | 3.8 | 4.7 | 5.6 | 6.5 |
| K=8 | A= | 0.1 | 0.2 | 0.3 | 0.4 | 0.5 | 0.6 | 0.8 | 0.9 | 1.1 | 1.3 | 1.6 | 1.8 | 2.5 | 3.3 | 4.2 | 5.1 | 6.0 |
| K=9 | A= | 0.1 | 0.2 | 0.3 | 0.4 | 0.5 | 0.6 | 0.8 | 0.9 | 1.1 | 1.3 | 1.5 | 1.8 | 2.1 | 2.9 | 3.7 | 4.6 | 5.4 |

| K= | 3 | 4 | 5 | 6 | 7 | 8 | 9 |
|-----------|-----|-----|-----|-----|-----|-----|-----|
| L= | 0.0 | 0.0 | 0.0 | 0.0 | 0.0 | 0.3 | 1.3 |

The above values are calculated on the assumption that the doors have square edges. They are reduced if the doors have radiused edges.

Un rayon adéquat de la porte réduit les valeurs de "A" et de "L".

Projection of the door
 Projection of the door from the cabinet side at the maximum opening. The figures are based on a straight arm hinge, H=0 mm thickness of mounting plate and K value = 3 mm.

Recul de la porte
 Recul de la porte par rapport au côté en position d'ouverture maximum (valeur obtenue avec une charnière bras droit, hauteur de l'embase H=0 et valeur K=3)

Series 200, 300 and 800 110°
Space needed to open the door

Série 200, 300 et 800 110°
Jeu nécessaire pour l'ouverture de la porte

| | T= | 16 | 17 | 18 | 19 | 20 | 21 | 22 | 23 | 24 | 25 | 26 |
|-----|-----------|-----|-----|-----|-----|-----|-----|-----|-----|-----|-----|-----|
| K=3 | A= | 0.5 | 0.7 | 0.9 | 1.2 | 1.5 | 1.8 | 2.4 | 3.7 | 5.1 | 6.5 | 7.8 |
| K=4 | A= | 0.5 | 0.7 | 0.9 | 1.2 | 1.5 | 1.8 | 2.1 | 2.7 | 4.1 | 5.5 | 6.8 |
| K=5 | A= | 0.5 | 0.7 | 0.9 | 1.2 | 1.5 | 1.8 | 2.1 | 2.6 | 3.1 | 4.1 | 5.4 |
| K=6 | A= | 0.5 | 0.7 | 0.9 | 1.2 | 1.5 | 1.8 | 2.1 | 2.5 | 3.0 | 3.5 | 4.4 |

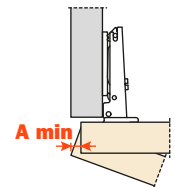

| | T= | 16 | 17 | 18 | 19 | 20 | 21 | 22 | 23 | 24 | 25 | 26 |
|-----|-----------|-----|-----|-----|-----|-----|-----|-----|-----|-----|-----|-----|
| K=3 | L= | 0.0 | 0.0 | 0.0 | 0.0 | 0.2 | 0.5 | 0.8 | 1.1 | 1.4 | 1.7 | 1.9 |
| K=4 | L= | 0.0 | 0.0 | 0.3 | 0.6 | 0.9 | 1.2 | 1.4 | 1.7 | 2.0 | 2.3 | 2.6 |
| K=5 | L= | 1.1 | 1.3 | 1.6 | 1.8 | 2.1 | 2.3 | 2.6 | 2.9 | 3.1 | 3.4 | 3.6 |
| K=6 | L= | 2.0 | 2.3 | 2.5 | 2.8 | 3.1 | 3.3 | 3.6 | 3.8 | 4.1 | 4.3 | 4.6 |

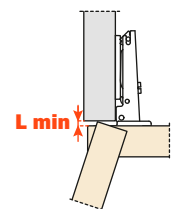

The above values are calculated on the assumption that the doors have square edges. They are reduced if the doors have radiused edges.

Un rayon adéquat de la porte réduit les valeurs de "A" et de "L".

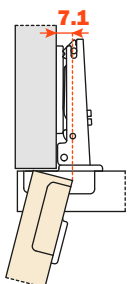

Projection of the door

Projection of the door from the cabinet side at the maximum opening. The figures are based on a straight arm hinge, H=0 mm thickness of mounting plate and K value = 3 mm.

Recul de la porte

Recul de la porte par rapport au côté en position d'ouverture maximum (valeur obtenue avec une charnière bras droit, hauteur de l'embase H=0 et valeur K=3)

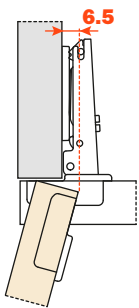

200 series • 120° Space needed to open the door

| | T= | 16 | 17 | 18 | 19 | 20 | 21 | 22 | 23 | 24 | 25 | 26 |
|-----|-----------|-----|-----|-----|-----|-----|-----|-----|-----|-----|-----|------|
| K=3 | A= | 1.0 | 1.3 | 1.6 | 1.9 | 2.2 | 3.5 | 5.0 | 6.5 | 8.1 | 9.6 | 11.2 |
| K=4 | A= | 1.0 | 1.3 | 1.5 | 1.9 | 2.2 | 2.5 | 4.0 | 5.5 | 7.1 | 8.6 | 10.2 |
| K=5 | A= | 1.0 | 1.2 | 1.5 | 1.8 | 2.1 | 2.5 | 3.0 | 4.5 | 6.1 | 7.6 | 9.2 |
| K=6 | A= | 1.0 | 1.2 | 1.5 | 1.8 | 2.1 | 2.4 | 2.8 | 3.5 | 5.1 | 6.6 | 8.1 |

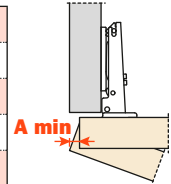

| | T= | 16 | 17 | 18 | 19 | 20 | 21 | 22 | 23 | 24 | 25 | 26 |
|-----|-----------|-----|-----|-----|-----|-----|-----|-----|-----|-----|-----|-----|
| K=3 | L= | 0.0 | 0.0 | 0.0 | 0.0 | 0.1 | 0.5 | 0.9 | 1.3 | 1.7 | 2.1 | 2.5 |
| K=4 | L= | 0.0 | 0.0 | 0.2 | 0.6 | 1.0 | 1.4 | 1.8 | 2.2 | 2.6 | 3.1 | 3.5 |
| K=5 | L= | 0.3 | 0.7 | 1.1 | 1.5 | 1.9 | 2.3 | 2.8 | 3.2 | 3.6 | 4.0 | 4.4 |
| K=6 | L= | 1.2 | 1.6 | 2.0 | 2.4 | 2.8 | 3.3 | 3.7 | 4.1 | 4.5 | 4.9 | 5.3 |

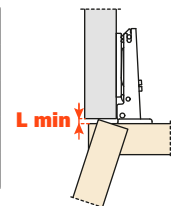

The above values are calculated on the assumption that the doors have square edges. They are reduced if the doors have radiused edges.

Un rayon adéquat de la porte réduit les valeurs de "A" et de "L".

Projection of the door

Projection of the door from the cabinet side at the maximum opening. The figures are based on a straight arm hinge, H=0 mm thickness of mounting plate and K value = 3 mm.

Recul de la porte

Recul de la porte par rapport au côté en position d'ouverture maximum (valeur obtenue avec une charnière bras droit, hauteur de l'embase H=0 et valeur K=3)

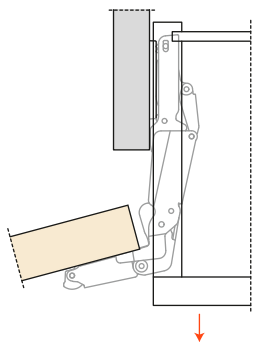

200 series • 165° Space needed to open the door

| | T= | 16 | 18 | 20 | 22 | 24 | 26 | 28 |
|-----|-----------|-----|-----|-----|-----|-----|-----|-----|
| K=3 | A= | 0.0 | 0.0 | 0.0 | 0.7 | 2.7 | 4.6 | 7.9 |
| K=4 | A= | 0.0 | 0.0 | 0.0 | 0.1 | 1.8 | 3.8 | 6.9 |
| K=5 | A= | 0.0 | 0.0 | 0.0 | 0.1 | 1.2 | 3.0 | 5.9 |
| K=6 | A= | 0.0 | 0.0 | 0.0 | 0.1 | 0.9 | 2.5 | 4.9 |
| K=7 | A= | 0.0 | 0.0 | 0.0 | 0.1 | 0.7 | 2.0 | 3.9 |
| K=8 | A= | 0.0 | 0.0 | 0.0 | 0.1 | 0.6 | 1.7 | 3.2 |

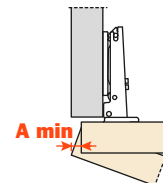

The above values are calculated on the assumption that the doors have square edges. They are reduced if the doors have radiused edges.

Un rayon adéquat de la porte réduit les valeurs de "A" et de "L".

Space needed to open the door Jeu nécessaire pour l'ouverture de la porte

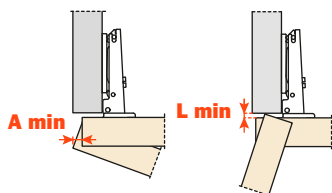

F series • 94° (40 mm ø cup) for THICK DOORS.
Space needed to open the door

Série F • 94° (boîtier ø 40 mm) pour PORTE EPAISSES.
Jeu nécessaire pour l'ouverture de la porte

| | T= | 20 | 21 | 22 | 23 | 24 | 25 | 26 | 27 | 28 | 29 | 30 | 31 | 32 | 33 | 34 | 35 | 36 | 37 | 38 | 39 | 40 | L= |
|------|----|-----|-----|-----|-----|-----|-----|-----|-----|-----|-----|-----|-----|-----|-----|-----|-----|-----|-----|-----|-----|-----|-----|
| K=3 | A= | 0.4 | 0.5 | 0.7 | 0.8 | 1.0 | 1.2 | 1.4 | 1.6 | 1.9 | 2.2 | 2.5 | 2.8 | 3.1 | 3.5 | 4.1 | 5.0 | 6.0 | 6.9 | 7.8 | 8.8 | 9.7 | 0.0 |
| K=4 | A= | 0.4 | 0.5 | 0.7 | 0.8 | 1.0 | 1.2 | 1.4 | 1.6 | 1.9 | 2.1 | 2.4 | 2.7 | 3.0 | 3.4 | 3.8 | 4.4 | 5.3 | 6.3 | 7.2 | 8.1 | 9.0 | 0.0 |
| K=5 | A= | 0.4 | 0.5 | 0.6 | 0.8 | 1.0 | 1.2 | 1.4 | 1.6 | 1.8 | 2.1 | 2.4 | 2.7 | 3.0 | 3.3 | 3.7 | 4.1 | 4.8 | 5.7 | 6.6 | 7.5 | 8.4 | 0.0 |
| K=6 | A= | 0.4 | 0.5 | 0.6 | 0.8 | 0.9 | 1.1 | 1.3 | 1.6 | 1.8 | 2.1 | 2.3 | 2.6 | 2.9 | 3.3 | 3.6 | 4.0 | 4.4 | 5.2 | 6.0 | 6.9 | 7.8 | 0.0 |
| K=7 | A= | 0.4 | 0.5 | 0.6 | 0.8 | 0.9 | 1.1 | 1.3 | 1.5 | 1.8 | 2.0 | 2.3 | 2.6 | 2.9 | 3.2 | 3.6 | 3.9 | 4.3 | 4.8 | 5.5 | 6.4 | 7.3 | 0.0 |
| K=8 | A= | 0.4 | 0.5 | 0.6 | 0.8 | 0.9 | 1.1 | 1.3 | 1.5 | 1.7 | 2.0 | 2.2 | 2.5 | 2.8 | 3.1 | 3.5 | 3.8 | 4.2 | 4.7 | 5.1 | 5.9 | 6.8 | 0.0 |
| K=9 | A= | 0.4 | 0.5 | 0.6 | 0.7 | 0.9 | 1.1 | 1.3 | 1.5 | 1.7 | 2.0 | 2.2 | 2.5 | 2.8 | 3.1 | 3.4 | 3.8 | 4.2 | 4.6 | 5.0 | 5.5 | 6.3 | 0.0 |
| K=10 | A= | 0.3 | 0.5 | 0.6 | 0.7 | 0.9 | 1.1 | 1.3 | 1.5 | 1.7 | 1.9 | 2.2 | 2.4 | 2.7 | 3.0 | 3.4 | 3.7 | 4.1 | 4.5 | 4.9 | 5.4 | 6.0 | 0.0 |
| K=11 | A= | 0.3 | 0.4 | 0.6 | 0.7 | 0.9 | 1.0 | 1.2 | 1.4 | 1.7 | 1.9 | 2.1 | 2.4 | 2.7 | 3.0 | 3.3 | 3.6 | 4.0 | 4.4 | 4.8 | 5.2 | 5.7 | 0.0 |
| K=12 | A= | 0.3 | 0.4 | 0.6 | 0.7 | 0.9 | 1.0 | 1.2 | 1.4 | 1.6 | 1.9 | 2.1 | 2.4 | 2.6 | 2.9 | 3.3 | 3.6 | 3.9 | 4.3 | 4.7 | 5.1 | 5.6 | 0.4 |
| K=13 | A= | 0.3 | 0.4 | 0.5 | 0.7 | 0.9 | 1.0 | 1.2 | 1.4 | 1.6 | 1.8 | 2.1 | 2.3 | 2.6 | 2.9 | 3.2 | 3.5 | 3.8 | 4.2 | 4.5 | 4.9 | 5.4 | 1.2 |
| K=14 | A= | 0.3 | 0.4 | 0.5 | 0.7 | 0.8 | 1.0 | 1.2 | 1.4 | 1.6 | 1.8 | 2.0 | 2.3 | 2.6 | 2.8 | 3.2 | 3.5 | 3.8 | 4.2 | 4.5 | 4.9 | 5.4 | 2.2 |
| K=15 | A= | 0.3 | 0.4 | 0.5 | 0.7 | 0.8 | 1.0 | 1.2 | 1.4 | 1.6 | 1.8 | 2.0 | 2.3 | 2.6 | 2.8 | 3.2 | 3.5 | 3.8 | 4.2 | 4.5 | 4.9 | 5.4 | 3.2 |

The above values are calculated on the assumption that the doors have square edges. They are reduced if the doors have radiused edges.

Un rayon adéquat de la porte réduit les valeurs de "A" et de "L".

Projection of the door

Projection of the door from the cabinet side at the maximum opening. The figures are based on a straight arm hinge, H=0 mm thickness of mounting plate and K value = 3 mm.

Recul de la porte

Recul de la porte par rapport au côté en position d'ouverture maximum (valeur obtenue avec une charnière bras droit, hauteur de l'embase H=0 et valeur K=3)

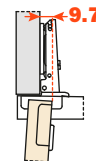

Projection of the door

Projection of the door from the cabinet side at the maximum opening. The figures are based on a straight arm hinge, H=0 mm thickness of mounting plate and K value = 3 mm.

Recul de la porte

Recul de la porte par rapport au côté en position d'ouverture maximum (valeur obtenue avec une charnière bras droit, hauteur de l'embase H=0 et valeur K=3)

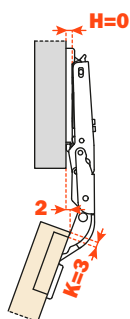

Universal hinges series • 110° Space needed to open the door

| | T= | 16 | 18 | 20 | 22 | 24 | 26 |
|------|----|-----|-----|-----|-----|------|------|
| K=3 | A= | 0.0 | 0.0 | 0.0 | 0.0 | 0.3 | 1.4 |
| K=4 | A= | 0.0 | 0.0 | 0.0 | 0.0 | 0.4 | 16.9 |
| K=5 | A= | 0.0 | 0.0 | 0.0 | 0.0 | 0.5 | 15.9 |
| K=6 | A= | 0.0 | 0.0 | 0.0 | 0.0 | 0.7 | 14.9 |
| K=7 | A= | 0.0 | 0.0 | 0.0 | 0.0 | 11.3 | 13.9 |
| K=8 | A= | 0.0 | 0.0 | 0.0 | 0.0 | 10.3 | 12.9 |
| K=9 | A= | 0.0 | 0.0 | 0.0 | 0.0 | 9.3 | 11.9 |
| K=10 | A= | 0.0 | 0.0 | 0.0 | 6.0 | 8.3 | 10.9 |
| K=11 | A= | 0.0 | 0.0 | 0.0 | 5.1 | 7.3 | 9.9 |
| K=12 | A= | 0.0 | 0.0 | 0.0 | 4.1 | 6.3 | 8.9 |
| K=13 | A= | 0.0 | 0.0 | 1.4 | 3.3 | 5.3 | 7.9 |
| K=14 | A= | 0.0 | 0.0 | 0.7 | 2.6 | 4.5 | 6.9 |
| K=15 | A= | 0.0 | 0.0 | 0.2 | 2.0 | 3.8 | 5.9 |
| K=16 | A= | 0.0 | 0.0 | 0.0 | 1.4 | 3.2 | 5.0 |
| K=17 | A= | 0.0 | 0.0 | 0.0 | 1.0 | 2.7 | 4.4 |
| K=18 | A= | 0.0 | 0.0 | 0.0 | 0.7 | 2.2 | 3.9 |

Charnières Universelles • 110° Jeu nécessaire pour l'ouverture de la porte

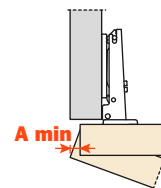

The above values are calculated on the assumption that the doors have square edges. They are reduced if the doors have radiused edges.

Un rayon adéquat de la porte réduit les valeurs de "A" et de "L".

**200 series • Special H Series
155° wide angle hinges series.**

**Série 200 • Série spéciale H
155° grand angle**

| | T= | 27 | 28 | 29 | 30 | 31 | 32 | 33 | 34 | 35 | 36 |
|-----|-----------|-----|-----|-----|-----|-----|-----|-----|-----|-----|-----|
| K=3 | A= | 0.0 | 0.0 | 0.2 | 0.6 | 0.8 | 1.0 | 1.4 | 1.9 | 2.3 | 3.0 |
| K=4 | A= | 0.0 | 0.0 | 0.2 | 0.6 | 0.8 | 1.0 | 1.4 | 1.9 | 2.3 | 3.0 |
| K=5 | A= | 0.0 | 0.0 | 0.2 | 0.6 | 0.8 | 1.1 | 1.5 | 1.9 | 2.5 | 3.2 |
| K=6 | A= | 0.0 | 0.0 | 0.2 | 0.6 | 0.8 | 1.2 | 1.6 | 1.9 | 2.5 | 3.8 |
| K=7 | A= | 0.0 | 0.0 | 0.2 | 0.6 | 0.8 | 1.3 | 1.7 | 2.1 | 2.7 | 3.9 |
| K=8 | A= | 0.0 | 0.0 | 0.2 | 0.6 | 0.8 | 1.4 | 1.7 | 2.1 | 2.7 | 4.0 |
| K=9 | A= | 0.0 | 0.0 | 0.2 | 0.6 | 0.8 | 1.4 | 1.7 | 2.1 | 3.0 | 4.0 |

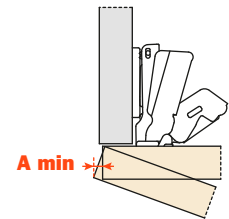

The above values are calculated on the assumption that the doors have square edges. They are reduced if the doors have radiused edges.

Un rayon adéquat de la porte réduit les valeurs de "A" et de "L".

**200 series • K Series, Zero protrusion,
Wide angle hinge series.**

**Série 200 • Série K, sans recul de la porte
Grand angle**

| | T= | 16 | 18 | 20 | 22 | 24 | 25 | 26 | 27 | 28 |
|-----|-----------|-----|-----|-----|-----|------|------|------|--------------|--------------|
| K=3 | A= | 0.0 | 0.0 | 0.0 | 0.0 | 0.0 | 0.10 | 0.40 | 0.75 | 1.20 |
| K=4 | A= | 0.0 | 0.0 | 0.0 | 0.0 | 0.0 | 0.15 | 0.45 | 0.85 | 1.35 |
| K=5 | A= | 0.0 | 0.0 | 0.0 | 0.0 | 0.0 | 0.20 | 0.50 | 0.95 | 120° 1.70 |
| K=6 | A= | 0.0 | 0.0 | 0.0 | 0.0 | 0.0 | 0.25 | 0.60 | 1.10 | 120° 1.95 |
| K=7 | A= | 0.0 | 0.0 | 0.0 | 0.0 | 0.0 | 0.30 | 0.70 | 1.30 | 100° 2.30 |
| K=8 | A= | 0.0 | 0.0 | 0.0 | 0.0 | 0.0 | 0.35 | 0.85 | 120° 1.70 | 100° 2.80 |
| K=9 | A= | 0.0 | 0.0 | 0.0 | 0.0 | 0.15 | 0.55 | 1.20 | 100° 2.15 | 92° 3.90 |

**With stop device at 100° item S2BM37XG
Avec arrêt pour limiter l'ouverture à 100° article S2BM37XG**

**With stop device at 120° item S2AM37XG
Avec arrêt pour limiter l'ouverture à 120° article S2AM37XG**

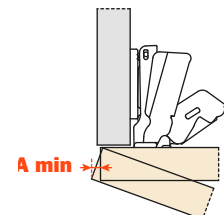

The above values are calculated on the assumption that the doors have square edges. They are reduced if the doors have radiused edges.

Un rayon adéquat de la porte réduit les valeurs de "A" et de "L".

Space needed to open the door
Jeu nécessaire pour l'ouverture de la porte

Projection of the door
 Projection of the door from the cabinet side at the maximum opening. The figures are based on a straight arm hinge, H=0 mm thickness of mounting plate and K value = 3 mm.

Recul de la porte
 Recul de la porte par rapport au côté en position d'ouverture maximum (valeur obtenue avec une charnière bras droit, hauteur de l'embase H=0 et valeur K=3)

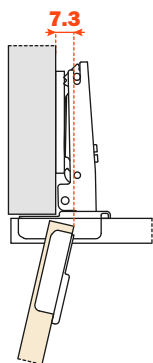

100 series • 105°
Space needed to open the door

| T= | 15 | 16 | 17 | 18 | 19 | 20 |
|-----|---------------|-----|-----|-----|-----|-----|
| K=3 | A= 1.0 | 1.0 | 1.2 | 1.4 | 1.6 | 1.9 |
| K=4 | A= 0.9 | 1.0 | 1.2 | 1.3 | 1.5 | 1.8 |
| K=5 | A= 0.9 | 1.0 | 1.1 | 1.2 | 1.5 | 1.8 |
| K=6 | A= 0.9 | 1.0 | 1.1 | 1.2 | 1.4 | 1.7 |

| T= | 15 | 16 | 17 | 18 | 19 | 20 |
|-----|---------------|-----|-----|-----|-----|-----|
| K=3 | L= 0.0 | 0.0 | 0.0 | 0.0 | 0.1 | 0.3 |
| K=4 | L= 0.4 | 0.6 | 0.7 | 0.9 | 1.1 | 1.2 |
| K=5 | L= 1.0 | 1.0 | 1.2 | 1.8 | 2.0 | 2.0 |
| K=6 | L= 1.6 | 1.8 | 2.0 | 2.1 | 2.3 | 2.5 |

Série 100 • 105°
Jeu nécessaire pour l'ouverture de la porte

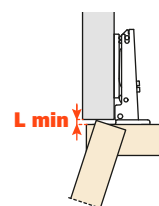
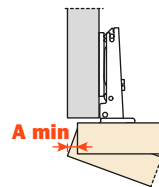

The above values are calculated on the assumption that the doors have square edges. They are reduced if the doors have radiused edges.

Un rayon adéquat de la porte réduit les valeurs de "A" et de "L".

Titanium finish Finition Titane



The Titanium finish perfectly integrates the hinge into the design of the cabinet conveying a sensation of warmth while at the same time, incorporating modern functionality.

The color, new and different compared to the traditional nickel-plated finishes, is less invasive and has a muted sheen. The Titanium reflections make the hinge ideal in combination with darker interiors and with the numerous shades of exotic wood finishes used in contemporary cabinetry.

Corrosion resistance is greatly enhanced compared to the traditional nickel-plated finishes.

In keeping with today's trends, this elegant Titanium finish is now available on both the standard hinge series as well as the Silentia+ soft close products.

La finition Titane intègre parfaitement la charnière dans le design du meuble. Elle donne une apparence chaleureuse et en même temps technologique.



La couleur, nouvelle et différente par rapport aux finitions traditionnelles brunies ou nickelées, est moins agressive et moins brillante. Les reflets titanes rendent cette charnière idéale pour les intérieurs sombres et les nombreuses tonalités des différentes essences de bois.

La résistance à la corrosion en est considérablement augmentée par rapport à la finition nickelée classique. Conformément aux tendances actuelles, cette élégante finition Titane est désormais disponible à la fois sur la série de charnières standard et sur les produits à fermeture amortie Silentia+.

More Exceptional products from Salice • Plus de produits exceptionnels de Salice



**Hinges and mounting plates
for all applications**

•
**Charnières et embases
pour toutes les applications**



Slides & Drawers

•
Coulisses & Tiroirs



Vertical lifting hardware

•
**Systèmes de levée et
de coulissement vertical**





Design accessories
•
**Accessoires de
conception**



**Coplanar sliding systems
&
Pocket door hardware**
•
**Systèmes coplanaires
&
Systèmes pour portes
escamotables**



**Storage accessories for
Closets & Kitchens**
•
**Systèmes de rangement
pour Armoires & Cuisines**



Table of contents • Index des références

| Part number Référence | page page | Part number Référence | page page | Part number Référence | page page | Part number Référence | page page | Part number Référence | page page |
|--------------------------|--------------|--------------------------|--------------|--------------------------|--------------|--------------------------|--------------|--------------------------|--------------|
| BARGR99/16 | 45 | BAP3R39 | 44 | BARGR29/16 | 45 | BAVGM69F/16 | 42 | C2J9D99 | 13 |
| B2R3E09/15 | 40 | BAP3R49 | 44 | BARGR29/20 | 45 | C1P6A99 | 12 | C2J9G99 | 13 |
| B2R3E39/15 | 40 | BAP3R69 | 44 | BARGR39/16 | 45 | C1P6D99 | 12 | C2JBA99 | 22 |
| B2R3E69/15 | 40 | BAP3R99 | 44 | BARGR39/20 | 45 | C1P6G99 | 12 | C2JBE99 | 17 |
| B2R3E99/15 | 40 | BAP3RC9 | 44 | BARGR49/16 | 45 | C1P6P99 | 12 | C2JBG99 | 22 |
| B2RGE09/17 | 40 | BAP7R09 | 44 | BARGR49/20 | 45 | C1R6A99 | 12 | C2JBH99 | 20 |
| B2RGE39/17 | 40 | BAP7R29 | 44 | BARGR69/16 | 45 | C1R6D99 | 12 | C2JBK99 | 17 |
| B2RGE69/17 | 40 | BAP7R39 | 44 | BARGR69/20 | 45 | C1R6G99 | 12 | C2JBM99 | 18 |
| B2RGE99/17 | 40 | BAP7R49 | 44 | BARGR99/20 | 45 | C1R6P99 | 12 | C2JBM99AC | 18 |
| B2V3BC9/15 | 40 | BAP7R69 | 44 | BARGRC/16 | 45 | C276A99 | 13 | C2JBN99 + B2S3B99B6/15 | 21 |
| B2V3BV9/15 | 40 | BAPGR09/16 | 44 | BARGRM9/16 | 46 | C276D99 | 13 | C2JBN99AC | 21 |
| B2V3BW9/15 | 41 | BAPGR29/16 | 44 | BARGRU9/16 | 46 | C276G99 | 13 | C2JBP99 | 22 |
| B2V3BW9R/15 | 41 | BAPGR39/16 | 44 | BARGRV9/16 | 45 | C276N99AM | 21 | C2JBT99 | 17 |
| B2V3BW9S/15 | 41 | BAPGR49/16 | 44 | BARGRY9/16 | 46 | C276P99 | 13 | C2JBU99 | 17 |
| B2V3H09/15 | 40 | BAPGR69/16 | 44 | BARGRZ9/16 | 46 | C279A99 | 13 | C2JBV99 | 18 |
| B2V3H29/15 | 40 | BAR3L09F | 43 | BAU3L19 | 47 | C279D99 | 13 | C2JBW99 | 20 |
| B2V3H39/15 | 40 | BAR3L39F | 43 | BAU3L49 | 47 | C279G99 | 13 | C2JBZ99 | 17 |
| B2V3H49/15 | 40 | BAR3L49F | 43 | BAU3R19 | 19 | C27BA99 | 22 | C2JFA99 | 14 |
| B2V3H69/15 | 40 | BAR3L69F | 43 | BAU3R19 | 47 | C27BE99 | 17 | C2JFD99 | 14 |
| B2V3H99/15 | 40 | BAR3R09 | 45 | BAU3R19XR | 47 | C27BG99 | 22 | C2JFG99 | 14 |
| B2V4H09/17 | 40 | BAR3R29 | 45 | BAU3R49 | 47 | C27BH99 | 20 | C2JFP99 | 14 |
| B2V4H29/17 | 40 | BAR3R39 | 45 | BAU3R49XR | 47 | C27BK99 | 17 | C2P4A99 | 13 |
| B2V4H39/17 | 40 | BAR3R49 | 45 | BAU3R69 | 47 | C27BM99 | 18 | C2P4D99 | 13 |
| B2V4H49/17 | 40 | BAR3R69 | 45 | BAU3R69XR | 47 | C27BM99AC | 18 | C2P4G99 | 13 |
| B2V4H69/17 | 40 | BAR3R99 | 45 | BAV3E99F | 42 | C27BN99 + B2S3B99B6/15 | 21 | C2P4P99 | 13 |
| B2VGB09/15 | 40 | BAR3RC9 | 45 | BAV3EC9F | 42 | C27BN99AC | 21 | C2P6A99 | 13 |
| B2VGBV9/15 | 40 | BAR3RM9 | 46 | BAV3EV9F | 42 | C27BP99 | 22 | C2P6D99 | 13 |
| B2VGBW9/17 | 41 | BAR3RU9 | 46 | BAV3M09F | 42 | C27BT99 | 17 | C2P6G99 | 13 |
| B2VGBW9R/17 | 41 | BAR3RV9 | 45 | BAV3M29F | 42 | C27BU99 | 17 | C2P6N99AM | 21 |
| B2VGBW9S/17 | 41 | BAR3RW9M | 41 | BAV3M39F | 42 | C27BV99 | 18 | C2P6P99 | 13 |
| B2VGH09/17 | 40 | BAR3RY9 | 46 | BAV3M49F | 42 | C27BW99 | 20 | C2P8A99 | 13 |
| B2VGH29/17 | 40 | BAR3RZ9 | 46 | BAV3M69F | 42 | C27BZ99 | 17 | C2P8D99 | 13 |
| B2VGH39/17 | 40 | BAR4R09/16 | 45 | BAV4M09F/16 | 42 | C27FA99 | 14 | C2P8G99 | 13 |
| B2VGH49/17 | 40 | BAR4R29/16 | 45 | BAV4M29F/16 | 42 | C27FD99 | 14 | C2P9A99 | 13 |
| B2VGH69/17 | 40 | BAR4R39/16 | 45 | BAV4M39F/16 | 42 | C27FG99 | 14 | C2P9D99 | 13 |
| B2VGH99/17 | 40 | BAR4R49/16 | 45 | BAV4M49F/16 | 42 | C27FP99 | 14 | C2P9G99 | 13 |
| B383E09 | 24 | BAR4R69/16 | 45 | BAVG99F/16 | 42 | C27YA99 | 18 | C2PAA99 | 22 |
| B383E69 | 24 | BARGL09F/16 | 43 | BAVGEC9F/16 | 42 | C2J6A99 | 13 | C2PAG99 | 22 |
| BA03R59 | 48 | BARGL39F/16 | 43 | BAVGEV9F/16 | 42 | C2J6D99 | 13 | C2PAP99 | 22 |
| BAL3R59 | 48 | BARGL39F/16 | 43 | BAVGM09F/16 | 42 | C2J6G99 | 13 | C2PBA99 | 22 |
| BAM3R09 | 48 | BARGL69F/16 | 43 | BAVGM29F/16 | 42 | C2J6N99AM | 21 | C2PBD99 | 22 |
| BAP3R09 | 44 | BARGR09/16 | 45 | BAVGM39F/16 | 42 | C2J6P99 | 13 | C2PBE99 | 17 |
| BAP3R29 | 44 | BARGR09/20 | 45 | BAVGM49F/16 | 42 | C2J9A99 | 13 | C2PBG99 | 22 |

| Part number Référence | page page | Part number Référence | page page | Part number Référence | page page | Part number Référence | page page | Part number Codigo | page page |
|--------------------------|--------------|--------------------------|--------------|--------------------------|--------------|--------------------------|--------------|-----------------------|--------------|
| C2PBH99 | 20 | C2R6G99 | 13 | C2RRA99 | 74 | CSP3A99N | 54 | DP29SNG | 63 |
| C2PBK99 | 17 | C2R6N99AM | 21 | C2RRG99 | 74 | CSP3A99NR | 56 | DP29SNGR | 63 |
| C2PBM99 | 18 | C2R6P99 | 13 | C2RRP99 | 74 | CSP3B99N | 54 | DP38XX91 | 67 |
| C2PBM99AC | 18 | C2R8A99 | 13 | C2RVA99 | 72 | CSP3B99NR | 56 | DP39XXG | 67 |
| C2PBN99 + B2S3B99B6/15 | 21 | C2R8D99 | 13 | C2RVG99 | 72 | CSP3C99N | 54 | DP3SN3 | 63 |
| C2PBN99AC | 21 | C2R8G99 | 13 | C2RVN99 + B2S3B99B6/15 | 75 | CSP3C99NR | 56 | DP3SNB | 63 |
| C2PBP99 | 22 | C2R9A99 | 13 | C2RVN99AC | 75 | CSP3D99N | 54 | DP3SNG | 63 |
| C2PBT99 | 17 | C2R9D99 | 13 | C2RVP99 | 72 | CSP3D99NR | 56 | DP4SN3 | 64 |
| C2PBU99 | 17 | C2R9G99 | 13 | C2RYA99 | 18 | CSP3E99N | 54 | DP4SNB | 64 |
| C2PBV99 | 18 | C2RAA99 | 22 | C2RYA99R | 19 | CSP3E99NR | 56 | DP4SNG | 64 |
| C2PBW99 | 20 | C2RAG99 | 22 | C3PBA99 | 24 | CSP3Y99 | 54 | DP50SNO | 64 |
| C2PBZ99 | 17 | C2RAP99 | 22 | C3RBA99 | 24 | CSP3Z99 | 54 | DP5SN3 | 64 |
| C2PEA99 | 14 | C2RBA99 | 22 | C876C99 | 25 | CSR3199N | 54 | DP5SNB | 64 |
| C2PED99 | 14 | C2RBD99 | 22 | C876J99 | 25 | CSR3299N | 54 | DP5SNG | 64 |
| C2PEG99 | 14 | C2RBE99 | 17 | C876L99 | 25 | CSR3299NR | 56 | DP82XXBR | 68 |
| C2PEP99 | 14 | C2RBG99 | 22 | C876S99 | 25 | CSR3499 | 54 | DP83XXBR | 68 |
| C2PFA99 | 14 | C2RBH99 | 20 | C8P6C99 | 25 | CSR3499XR | 56 | DP84SNBR | 68 |
| C2PFD99 | 14 | C2RBK99 | 17 | C8P6J99 | 25 | CSR3599 | 54 | DPASNB | 67 |
| C2PFG99 | 14 | C2RBM99 | 18 | C8P6L99 | 25 | CSR3599XR | 56 | DPMSNB | 67 |
| C2PFP99 | 14 | C2RBM99AC | 18 | C8P6S99 | 25 | CSR3699 | 54 | S2A637XF | 59 |
| C2PHA99 | 15 | C2RBN99 + B2S3B99B6/15 | 21 | C8R6C99 | 25 | CSR3699XR | 56 | S2AF37X3 | 59 |
| C2PKA99 | 23 | C2RBN99AC | 21 | C8R6J99 | 25 | CSR3799 | 54 | S2AM37XG | 60 |
| C2PKD99 | 23 | C2RBP99 | 22 | C8R6L99 | 25 | CSR3799XR | 56 | S2BF37XY | 59 |
| C2PKG99 | 23 | C2RBT99 | 17 | C8R6S99 | 25 | CSR3899 | 54 | S2BM37XG | 60 |
| C2PPA99 | 73 | C2RBU99 | 17 | CBP1AC9 | 26 | CSR3999 | 54 | S2BX83H9 | 58 |
| C2PPG99 | 73 | C2RBV99 | 18 | CBP2AC9 | 26 | CSR3A99N | 54 | S2CX85H9 | 58 |
| C2PPP99 | 73 | C2RBW99 | 20 | CBP2AE9 | 26 | CSR3A99NR | 56 | S2MX83H9 | 58 |
| C2PRA99 | 74 | C2RBZ99 | 17 | CBPQC9 | 26 | CSR3B99N | 54 | S2XX83A1 | 58 |
| C2PRG99 | 74 | C2REA99 | 14 | CMP3A99 | 30 | CSR3B99NR | 56 | S2XX85H9 | 58 |
| C2PRP99 | 74 | C2RED99 | 14 | CMR3A99 | 30 | CSR3C99N | 54 | SAV354X9R | 41 |
| C2PVA99 | 72 | C2REG99 | 14 | CSP3199N | 54 | CSR3C99NR | 56 | SAV354X9S | 41 |
| C2PVG99 | 72 | C2REP99 | 14 | CSP3299N | 54 | CSR3D99N | 54 | SBA237XG | 26 |
| C2PVN99 + B2S3B99B6/15 | 75 | C2RFA99 | 14 | CSP3299NR | 56 | CSR3D99NR | 56 | SBA237XG | 59 |
| C2PVN99AC | 75 | C2RFD99 | 14 | CSP3499 | 54 | CSR3E99N | 54 | SBAX78A6SN | 26 |
| C2PVP99 | 72 | C2RFG99 | 14 | CSP3499XR | 56 | CSR3E99NR | 56 | SBXX85X6 | 26 |
| C2PYA99 | 18 | C2RFP99 | 14 | CSP3599 | 54 | CSR3Y99 | 54 | SBXX85X9 | 26 |
| C2PYA99R | 19 | C2RHA99 | 15 | CSP3599XR | 56 | CSR3Z99 | 54 | SP44XX3 | 67 |
| C2R4A99 | 13 | C2RKA99 | 23 | CSP3699 | 54 | DBDESN6 | 26 | SP44XXB | 67 |
| C2R4D99 | 13 | C2RKD99 | 23 | CSP3699XR | 56 | DP28SN9 | 67 | SP44XXG | 67 |
| C2R4G99 | 13 | C2RKG99 | 23 | CSP3799 | 54 | DP29SN3 | 63 | SSP3377G | 60 |
| C2R4P99 | 13 | C2RPA99 | 73 | CSP3799XR | 56 | DP29SN3R | 63 | SSP337AG | 60 |
| C2R6A99 | 13 | C2RPG99 | 73 | CSP3899 | 54 | DP29SNB | 63 | SSXX83 | 58 |
| C2R6D99 | 13 | C2RPP99 | 73 | CSP3999 | 54 | DP29SNBR | 63 | | |

SALICE CANADA INC.

3500 RIDGEWAY DRIVE, UNIT#1
MISSISSAUGA, ONTARIO, L5L 0B4
TEL. 905 820 8787
FAX. 905 820 7226
info.salice@salicecanada.com
www.salicecanada.com

Authorized distributor:
Distributeur agréé:

We reserve all rights to this catalogue under copyright law. It shall not be permissible to duplicate this catalogue in any form either in whole or in part without our written consent. The technical specifications in this catalogue as photographs and drawings are not binding. We assume no liability for any misprints or errors that might occur in this catalogue.

Nous nous réservons tous les droits sur ce catalogue en vertu de la loi sur le droit d'auteur. Il n'est pas permis de dupliquer ce catalogue sous quelque forme que ce soit, en totalité ou en partie, sans notre consentement écrit. Les spécifications techniques de ce catalogue comme les photographies et les dessins ne sont pas contractuelles. Nous n'assumons aucune responsabilité pour les fautes d'impression ou les erreurs qui pourraient se produire dans ce catalogue.